

# Book 2020

# Book



2020

---

<b>Company</b>	<b>02</b>
<b>From nature to nature</b>	<b>09</b>
<b>Collections</b>	<b>17</b>
<b>OUT2.0</b>	<b>316</b>
<b>Trim tiles</b>	<b>344</b>
<b>Surfaces</b>	<b>346</b>
<b>Balneo project</b>	<b>348</b>
<b>Certifications</b>	<b>352</b>
<b>Color shading</b>	<b>368</b>
<b>Technical Features</b>	<b>372</b>
<b>Laying sketches</b>	<b>400</b>
<b>Installation and maintenance</b>	<b>406</b>
<b>General terms and conditions of sale</b>	<b>422</b>



**Ceramiche Refin è presente sui mercati internazionali dal 1962 con un'ampia gamma di soluzioni in gres porcellanato per l'abitazione privata e per il mondo del progetto. Refin fa parte del Gruppo Concorde, primario gruppo ceramico mondiale. L'impegno nella ricerca estetica e nell'innovazione tecnologica ha permesso all'azienda di raggiungere livelli di eccellenza nel prodotto e nei processi produttivi, acquisendo una sempre maggiore competitività. Refin progetta e produce interamente in Italia gres porcellanato, attraverso una gestione d'azienda fondata sulla ricerca della qualità e sul rispetto dell'ambiente.**

**Ceramiche Refin has been a presence on the international market since 1962 with a broad range of porcelain stoneware solutions for residential and project-planning destinations. Refin is part of the Gruppo Concorde, a leading ceramic group at global level. The constant commitment towards aesthetic research and technological innovation has seen the company achieve product and production excellence, thus becoming more and more competitive. Refin designs and produces porcelain stoneware in-house and only in Italy, running a company that is based on the pursuit of quality and on respecting the Environment.**

#### Ceramiche Refin

La société Ceramiche Refin est présente sur les marchés internationaux depuis 1962 avec une large gamme de solutions en grès cérame destinées aux habitations privées et au monde des concepteurs. Elle fait partie du Groupe Concorde, grand groupe mondial de production de céramique. Son engagement dans le développement des aspects esthétiques et dans l'innovation technologique a permis à la société d'atteindre des niveaux d'excellence dans les produits et les processus de production lui permettant d'être toujours plus compétitive. Ceramiche Refin conçoit et produit le grès cérame entièrement en Italie, grâce à une gestion d'entreprise fondée sur la recherche de la qualité et le respect de l'environnement.

#### Ceramiche Refin

Ceramiche Refin ist seit 1962 auf den internationalen Märkten mit einer breiten Auswahl an Feinsteinzeuglösungen für das private Wohnen und die Welt der Planung präsent. Refin gehört zur Gruppe Concorde, ein primärer Keramikkonzern in Europa. Das Engagement in der ästhetischen Forschung und in der technologischen Innovation hat es der Firma ermöglicht, Produkte und Produktionsprozesse von ausgezeichnetem Niveau zu erzielen und so immer konkurrenzfähiger zu werden. Bei der Planung und Realisierung von Feinsteinzeug in Italien legt die Geschäftsführung von Refin höchsten Wert auf Qualitätsforschung und Umweltfreundlichkeit.

#### Ceramiche Refin

Ceramiche Refin is sinds 1962 aanwezig op de internationale markt en biedt een ruime keuze aan oplossingen in gres porcellanato voor privéwoningen en voor de ontwerpwereld. Refin maakt deel uit van de Gruppo Concorde, een wereldwijd leidende groep tegelproducenten. Dankzij het esthetisch onderzoek en de technologische innovatie, zijn zowel producten zelf als de productieprocessen van zeer hoog niveau. Hierdoor heeft het bedrijf een steeds sterkere concurrentiepositie weten te bemachtigen. Refin ontwerpt en produceert gres porcellanato in een eigen productiefaciliteit in Italië en heeft als bedrijf kwaliteit en zorg voor het milieu hoog in het vaandel staan.

#### Ceramiche Refin

Ceramiche Refin está presente en los mercados internacionales desde 1962 con una amplia gama de soluciones en gres porcelánico para viviendas privadas y el mundo del diseño. Refin forma parte del Grupo Concorde, grupo cerámico líder en el mundo. El compromiso con la investigación estética y la innovación tecnológica ha permitido a la empresa alcanzar niveles de excelencia en los productos y en los procesos de producción, adquiriendo cada vez mayor competitividad. Refin diseña y fabrica gres porcelánico íntegramente en Italia, a través de una gestión de la empresa basada en la búsqueda de la calidad y el respeto por el medio ambiente.





**La capacità produttiva di Ceramiche Refin supera i 7 milioni di mq l'anno ed è supportata da impianti all'avanguardia per la realizzazione delle grafiche e delle attività di postlavorazione. Tutte le fasi del processo produttivo sono sottoposte a rigorose procedure di Controllo Qualità e gli eccellenti standard qualitativi dei nostri prodotti sono attestati dalle più prestigiose certificazioni internazionali.**

**Oggetto di orgoglio per Ceramiche Refin è il laboratorio creativo DesignTaleStudio, nato dall'incontro tra design e cultura artigianale italiana, la cui creatività viene alimentata da un team di professionisti ceramici e da importanti collaborazioni con i protagonisti dello stile contemporaneo. Refin e Dts offrono al mondo del progetto inedite interpretazioni creative e propongono soluzioni innovative nei materiali e nelle possibilità applicative.**

**Interpretiamo il "Made in Italy" non come una mera questione di stile, ma come un modello produttivo che coniuga l'espressività derivante dalla nostra storia e dalla nostra cultura con l'etica del lavoro che contraddistingue la tradizione manifatturiera italiana. Per questa ragione abbiamo sottoscritto il codice etico sul Made in Italy di Confindustria Ceramica, impegnandoci a dichiarare con trasparenza l'origine dei nostri prodotti.**

Ceramiche Refin produces more than 7 million m<sup>2</sup> of tiles per year, supported by avant-garde machinery for the creation of surface graphics and post-manufacturing processes. All the phases of our production process undergo strict Quality Control procedures and the excellent quality standards of our products are certified by the most important international certifications.

The jewel in the crown of Ceramiche Refin is the DesignTaleStudio creative laboratory, born out of the merger between design and Italian artisan tradition and whose creativity is constantly fed by a team of expert ceramic masters and important partnerships with the leading figures of contemporary design. Refin and Dts provide the world of design and architecture new tools for unexpected creative interpretations and suggest innovative solutions concerning materials and methods of application.

At Refin, "Made in Italy" does not only mean style, but it represents a productive model combining the creative flair typical of our culture with the work ethics that have always characterised Italian manufacturing tradition. For this reason, we have adhered to the Made in Italy ethical code promoted by Confindustria Ceramica, stating, with clarity and transparency, the origin of our products.



## Innovation et créativité

La capacité de production de Ceramiche Refin dépasse les 7 millions de m<sup>2</sup> par an et peut compter sur des installations à l'avant-garde pour la réalisation du graphisme et des activités de postproduction. Toutes les phases du procédé de production sont soumises aux procédures sévères de notre Contrôle Qualité et les plus prestigieuses certifications internationales attestent l'excellence des standards de qualité de nos produits.

Ceramiche Refin est particulièrement orgueilleuse de DesignTaleStudio, son laboratoire créatif, qui naît de la rencontre entre le design et la culture artisanale italienne et dont la créativité est alimentée par une équipe de professionnels de la céramique et par la collaboration des grands acteurs du design contemporain. Refin et Dts offrons au monde des concepteurs de nouveaux instruments permettant des interprétations créatives inédites et met au point des solutions innovantes pour les matériaux et leurs champs d'application.

Notre interprétation du «Made in Italy» n'est pas seulement une question de style, c'est un modèle de production conjuguant l'expressivité qui dérive de notre histoire et de notre culture avec l'éthique du travail qui caractérise la tradition industrielle italienne. C'est pour cette raison que nous avons signé le code éthique du Made In Italy rédigé par le Conseil d'administration de Confindustria Ceramica qui nous oblige à déclarer de façon transparente l'origine de nos produits.

## Innovation Und Kreativität

Die Produktionskapazität von Ceramiche Refin beträgt mehr als 7 Millionen Quadratmeter pro Jahr und wird von hochfortschrittlichen Anlagen für die Fertigung der Grafiken und der Nachbearbeitungen sowie von einem ständig in der Forschung. Alle Phasen des Produktionsprozesses werden strengen Prozeduren zur Qualitätskontrolle unterzogen und die ausgezeichneten Qualitätsstandards unserer Produkte werden von den prestigereichsten internationalen Zertifizierungen bestätigt.

Ein Grund zum Stolz ist für Ceramiche Refin das kreative Labor DesignTaleStudio, das der Begegnung zwischen Design und italienischer Handwerkskultur entspringt und dessen Kreativität von einem Team aus Keramikfachleuten und bedeutenden Zusammenarbeiten mit den wichtigsten Vertretern des zeitgenössischen Stils gespeist wird. Refin und Dts bieten der Welt der Planung brandneue kreative Interpretationsmöglichkeiten und schlagen sowohl bezüglich der Materialien, als auch bezüglich der Anwendungsmöglichkeiten innovative Lösungen vor.

Wir interpretieren das Motto "Made in Italy" nicht nur als reine Stilfrage, sondern als Produktionsmodell, das die Ausdruckskraft, die wir unserer Geschichte und Kultur verdanken, mit der Arbeitsethik verbindet, die die italienische Manufakturtradition auszeichnet. Aus diesem Grund haben wir den vom Vorstand von Confindustria Ceramica erstellten Ethikkodex unterzeichnet, in dem wir uns dafür engagieren, den Ursprung unserer Produkte mit aller Transparenz zu erklären.

## Innovatie en creativiteit

Ceramiche Refin heeft een productiecapaciteit van meer dan 7 miljoen vierkante meter per jaar en beschikt over geavanceerde machines voor de realisering van de grafische afwerking en de post-bewerkingsactiviteiten en tevens. Alle fases van het productieproces zijn onderhevig aan rigoureuze kwaliteitscontroleprocedures en de buitengewone kwaliteitsnormen van onze producten worden bewezen door de meest prestigieuze internationale certificaties.

Bijzonder trots is Ceramiche Refin op het creatieve laboratorium DesignTaleStudio, ontstaan uit de ontmoeting tussen design en Italiaanse ambachtscultuur, waarvan de creativiteit wordt versterkt door een team professionals in de keramieksector en door belangrijke samenwerkingen met de kopstukken van de eigentijdse stijl. Refin en Dts brengen onuitgegeven creatieve interpretaties voor de designwereld en bieden innovatieve oplossingen aan voor materialen en toepassingsmogelijkheden.

Wij interpreteren "Made in Italy" niet als een zuivere kwestie van stijl, maar eerder als een productiemodel dat de expressiviteit voortvloeiend uit onze geschiedenis en cultuur combineert met een professionele ethiek, eigen aan het traditionele Italiaanse productieproces. Daarom hebben wij de ethische code voor "Made in Italy" producten, opgesteld door de bestuursraad van de Confindustria ceramica (Italiaanse Industriegroep voor Keramiek), ondertekend. Dit betuigt van onze inzet voor transparantie van de oorsprong van onze producten.

## Innovación y creatividad

La capacidad productiva de Ceramiche Refin supera los 7 millones de m<sup>2</sup> al año y es sostenida por instalaciones a la vanguardia para la realización de los elementos gráficos y de las actividades de post-elaboración. Todas las fases del proceso productivo son sometidas a rigurosos procedimientos de control de calidad y los excelentes estándares cualitativos de nuestros productos son garantizados por las más prestigiosas certificaciones internacionales.

Objeto de orgullo para Ceramiche Refin es el Laboratorio Creativo DesignTaleStudio, nacido del encuentro entre diseño y cultura artesanal italiana, cuya creatividad es alimentada por un equipo de profesionales cerámicos y por importantes colaboraciones con los protagonistas del estilo contemporáneo. Refin y Dts le brindan al sector del proyecto inéditas interpretaciones creativas y le proponen soluciones innovadoras en cuanto a materiales y aplicaciones posibles.

Interpretamos el "Made in Italy" no sólo como una cuestión de estilo, sino como un modelo productivo que conjuga la expresividad que proviene de nuestra historia y de nuestra cultura con la ética del trabajo que caracteriza la tradición manufacturera italiana. Este es el motivo por el que hemos firmado el código ético del Made in Italy de Confindustria Ceramica y nos comprometemos con total transparencia a declarar el origen de nuestros productos.

# Dalla natura alla natura From nature to nature

8/9

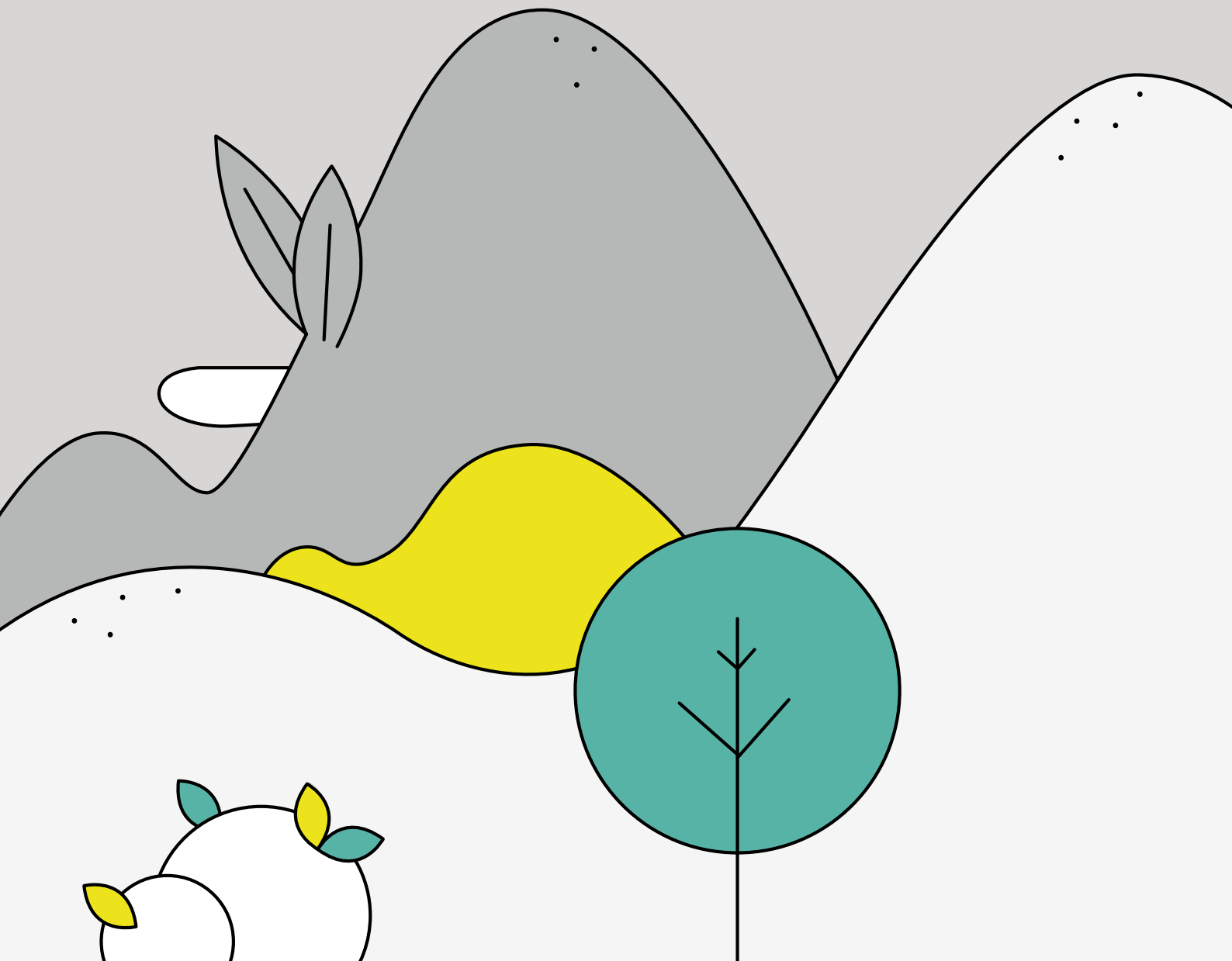

# La ceramica è viva!

Ceramic is alive!

## Rispetta l'ambiente

It respects the environment

**Refin utilizza materiali comuni in natura (sabbie e argille in prevalenza), materiali riciclati e recupera le acque utilizzate e il calore altrimenti disperso.**

Refin uses common natural materials (mainly sand and clay) and recycled materials, and recovers the water used and the heat that would otherwise be dispersed.

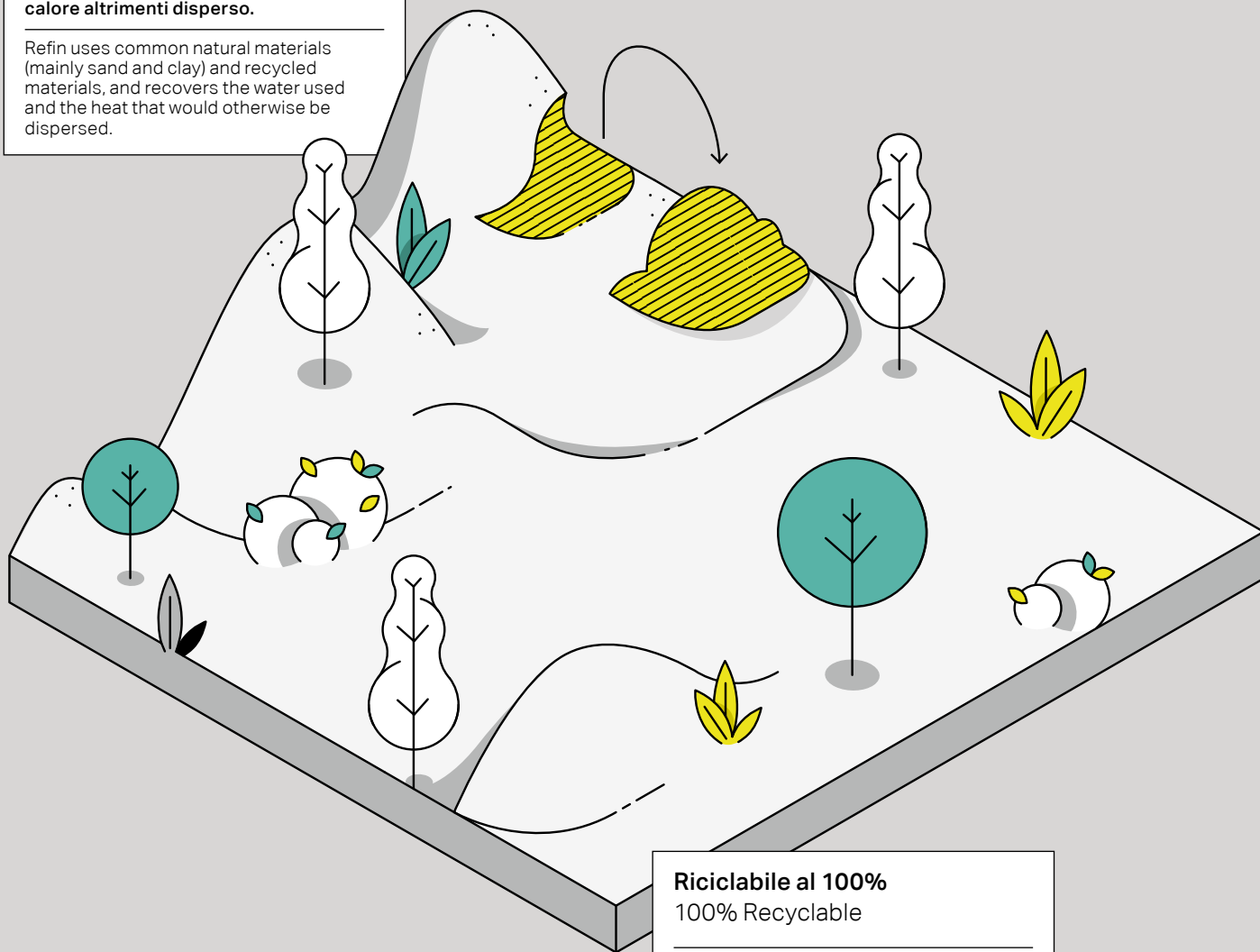

## Riciclabile al 100%

100% Recyclable

**Il gres porcellanato è riciclabile al 100% e può essere smaltito senza rischi per l'ambiente.**

Porcelain stoneware can be 100% recycled and disposed of with no risk to the environment.

# Della ceramica puoi fidarti

## You can trust ceramic

### Sicura / Safe

**Non contiene sostanze tossiche (ftalati, formaldeide, solventi, ammorbidenti o altri additivi chimici).**

It does not contain toxic substances (phthalates, formaldehyde, solvents, softeners or other chemical additives).

**Non emette VOC (sostanze organiche volatili) anche in caso di esposizione ad alte temperature o alla luce diretta del sole.**

It does not emit any VOCs (volatile organic compounds) even when exposed to high temperatures or direct sunlight.

**È ignifuga e non rilascia fumi in caso di incendio.**

It is fireproof and does not release smoke in case of a fire.

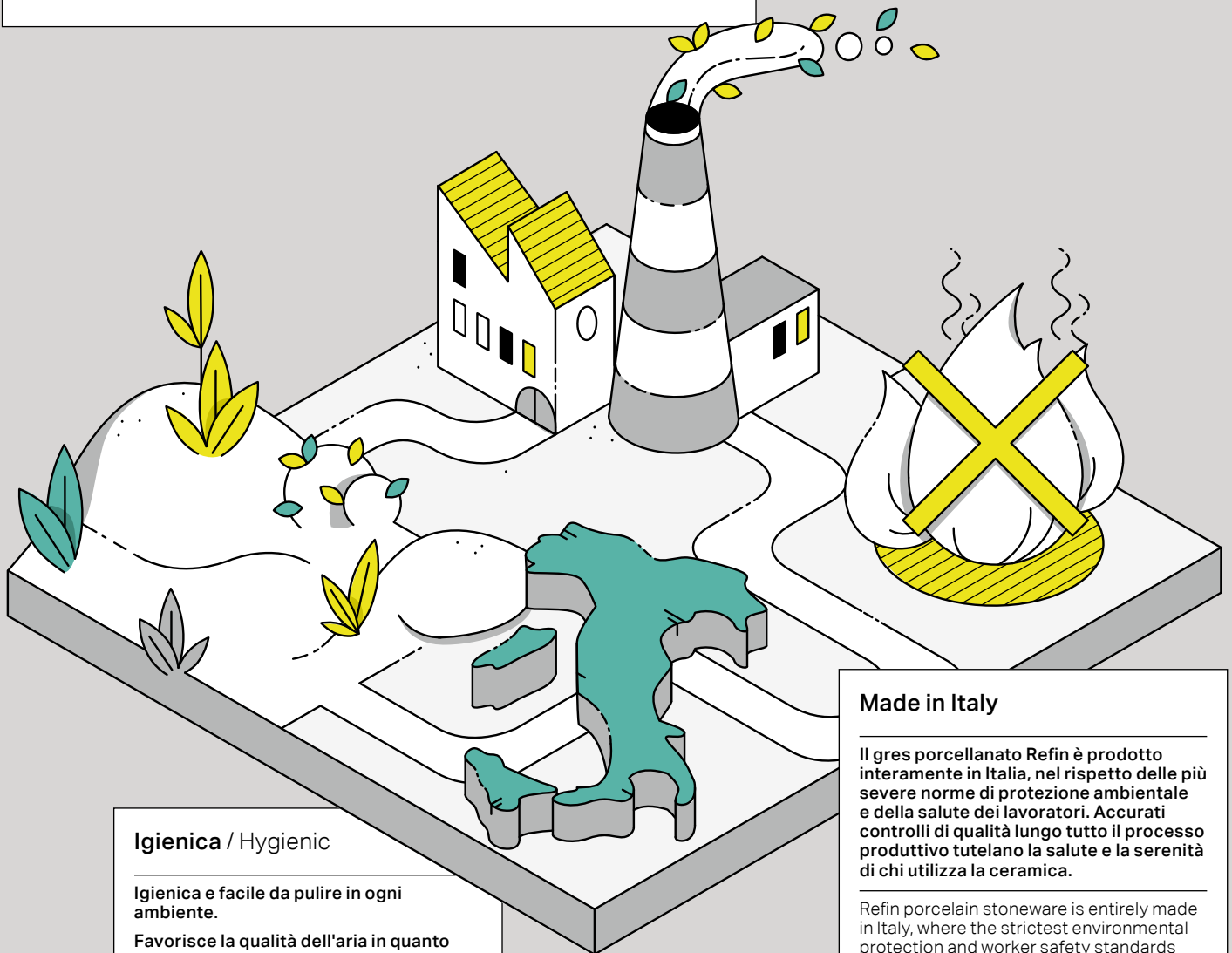

### Igienica / Hygienic

**Igienica e facile da pulire in ogni ambiente.**

**Favorisce la qualità dell'aria in quanto non assorbe umidità e odori sgradevoli.**

**È anallergica e ideale in presenza di animali domestici.**

It is hygienic and easy to clean in any environment.

It favours air quality in that it does not absorb humidity or unpleasant odours.

It is hypo-allergenic and ideal in the presence of pets.

### Made in Italy

**Il gres porcellanato Refin è prodotto interamente in Italia, nel rispetto delle più severe norme di protezione ambientale e della salute dei lavoratori. Accurati controlli di qualità lungo tutto il processo produttivo tutelano la salute e la serenità di chi utilizza la ceramica.**

Refin porcelain stoneware is entirely made in Italy, where the strictest environmental protection and worker safety standards are upheld. Accurate quality controls throughout the entire production process safeguard the health and well-being of the end consumer.

# La ceramica vale Ceramic is worth it

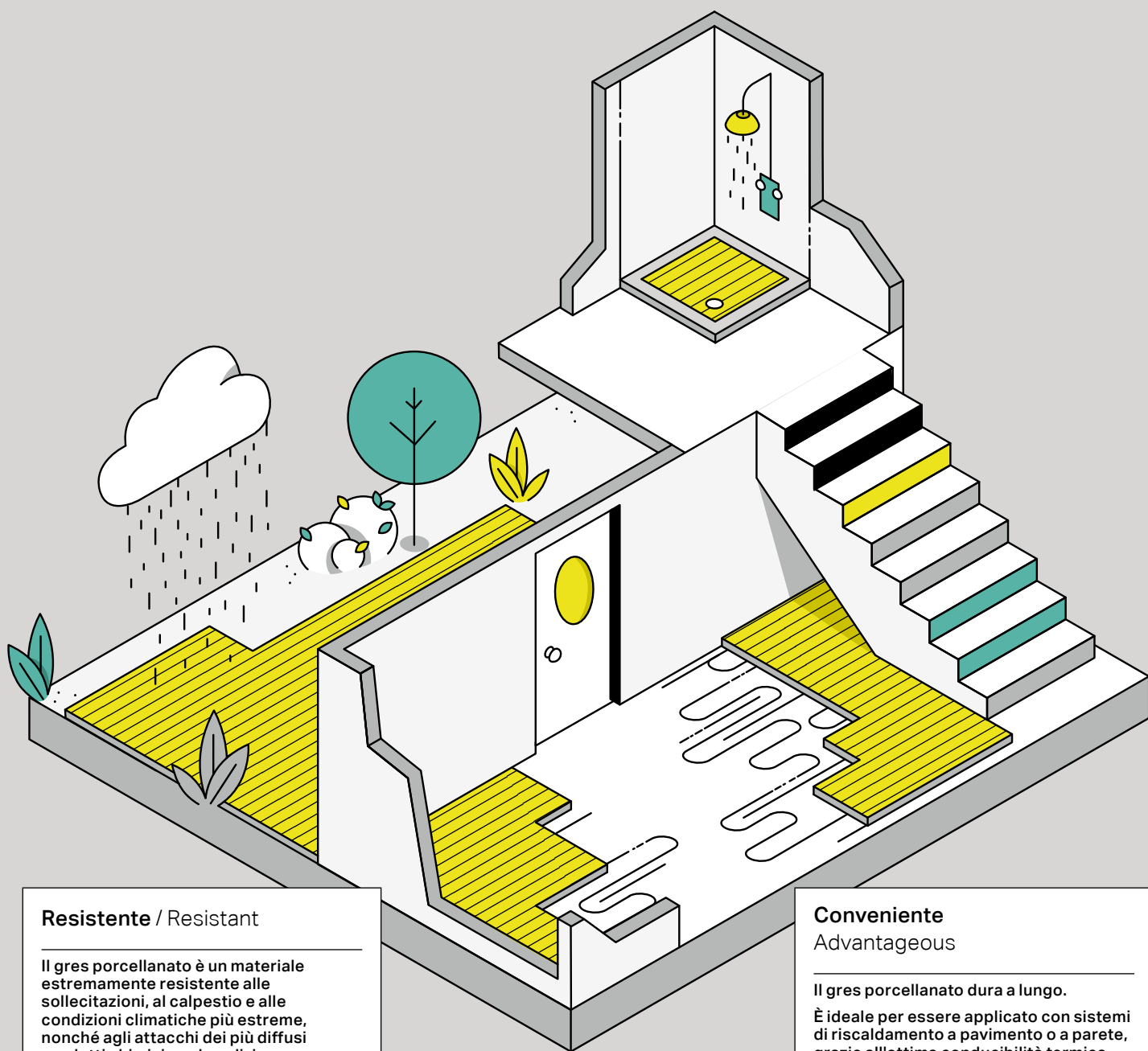

## Resistente / Resistant

**Il gres porcellanato è un materiale estremamente resistente alle sollecitazioni, al calpestio e alle condizioni climatiche più estreme, nonché agli attacchi dei più diffusi prodotti chimici per la pulizia.**

**Il gres non si deforma, non subisce decadimenti di colore, di grafica o di struttura.**

**Il gres è impermeabile e non viene danneggiato dagli sbalzi termici.**

Porcelain stoneware is a material that is extremely resistant to stress, trampling and the most extreme weather conditions, as well as attacks from commonly used chemical products.

Stoneware does not deform and does not suffer the deterioration of its colour, graphics or structure.

Stoneware is waterproof and cannot be damaged by sudden temperature changes.

## Conveniente

Advantageous

**Il gres porcellanato dura a lungo.**

**È ideale per essere applicato con sistemi di riscaldamento a pavimento o a parete, grazie all'ottima conducibilità termica.**

Porcelain stoneware is long lasting.

It is ideal for use with under-floor or wall heating systems, as it is an excellent heat conductor.

# La ceramica Refin ti emoziona!

## Refin ceramics will excite you!

From Nature to Nature  
12/13

### Bella / Beautiful

I consumatori di tutto il mondo preferiscono la ceramica: oltre il 60% delle pavimentazioni vengono realizzate con questo materiale.

Le grafiche Refin esprimono profondità e matericità, nonché ineguagliabili rese matt/lucido, sviluppate attraverso una speciale combinazione di tecnica e creatività.

Consumers all over the world choose ceramic: more than 60% of floorings are made out of this material.

Refin graphics boast a depth and consistency, as well as an unrivalled matte/polished finish, developed according to a special combination of technology and creativity.

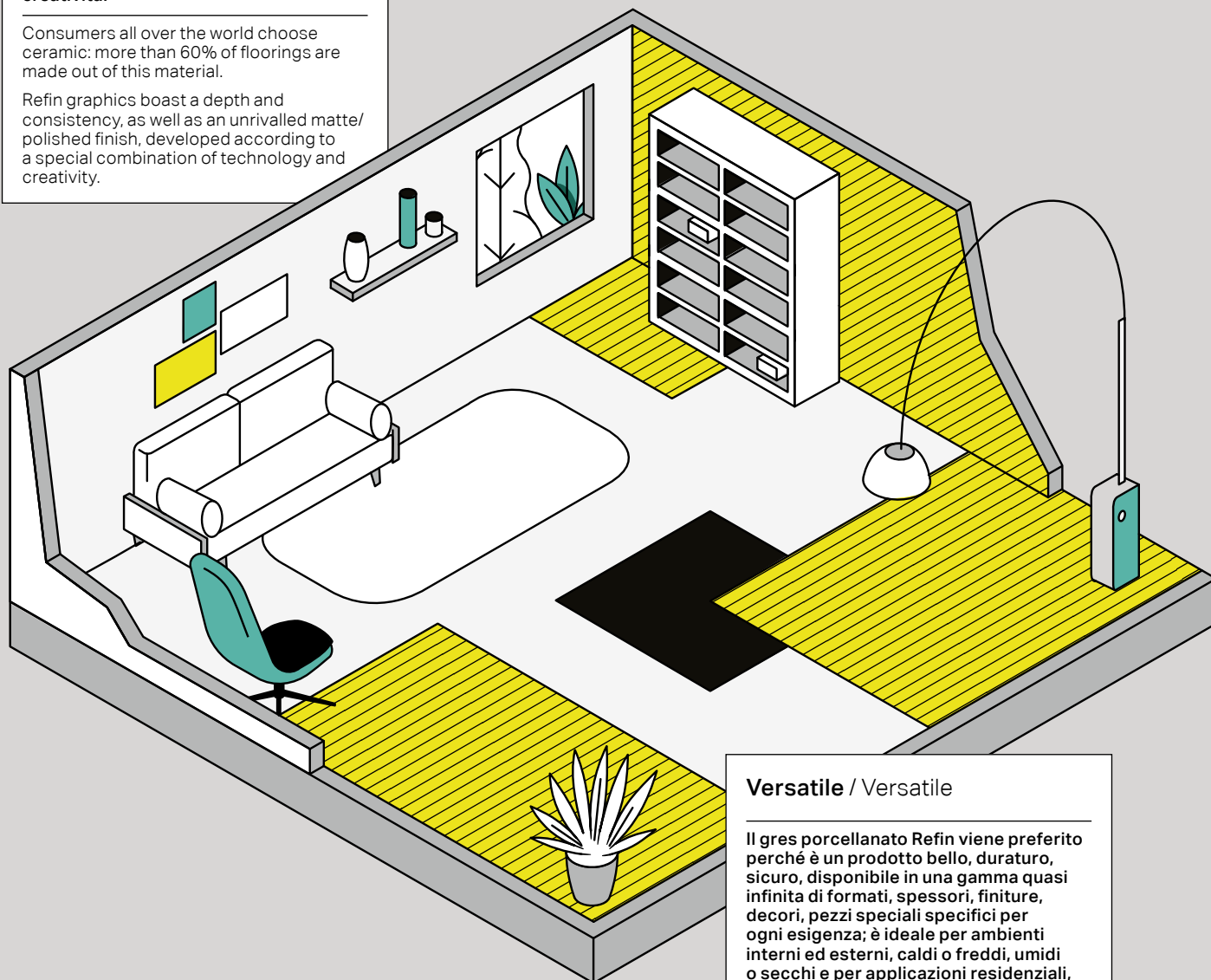

### Versatile / Versatile

Il gres porcellanato Refin viene preferito perché è un prodotto bello, duraturo, sicuro, disponibile in una gamma quasi infinita di formati, spessori, finiture, decori, pezzi speciali specifici per ogni esigenza; è ideale per ambienti interni ed esterni, caldi o freddi, umidi o secchi e per applicazioni residenziali, commerciali, pubblici o che richiedono specifiche tecniche particolari.

Refin porcelain stoneware is chosen because it is beautiful, durable, safe, and available in an almost infinite range of sizes, thicknesses, finishes, decorations, and special pieces to suit every need. It is ideal for indoor and outdoor environments, hot or cold, damp or dry and for residential, commercial or public applications, as well as those that have particular technical specifications.

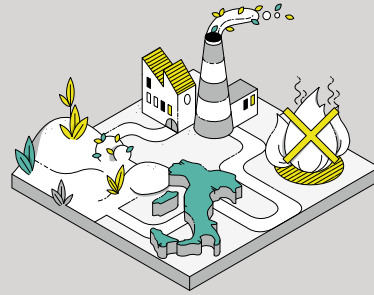
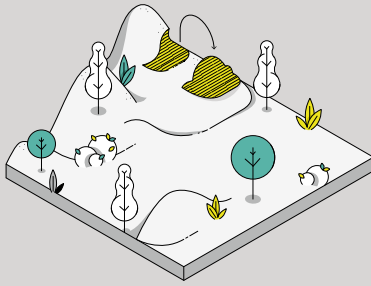

F

**LA CÉRAMIQUE EST VIVANTE !**

**Respect de l'environnement**

Refin utilise des matériaux présents dans la nature (sables et argiles principalement), des matériaux recyclés et récupère les eaux utilisées et la chaleur qui, sinon, serait perdue.

**100% recyclable**

Le grès cérame est recyclable à 100 % et peut être éliminé sans risques pour l'environnement.

D

**KERAMIK LEBT!**

**Sie ist umweltfreundlich**

Refin verwendet in der Natur übliche Materialien (hauptsächlich Sand und Ton), recycelte Materialien und gewinnt das für die Produktion verwendete Wasser und die Wärme zurück, die sonst vergeudet würden.

**100% recycelbar**

Feinsteinzeug ist zu 100% recycelbar und kann umweltfreundlich entsorgt werden.

N

**KERAMIEK LEEFT!**

**Eerbied voor het milieu**

Refin gebruikt materialen die afkomstig zijn uit de natuur (voornamelijk zand en klei) en gerecyclede materialen, en wint gebruikt water en warmte terug die anders verloren zouden gaan.

**100% recyclebaar**

Porseleingres is 100% recyclebaar en kan zonder milieurisico's als afval worden verwerkt.

E

**¡LA CERÁMICA ESTÁ VIVA!**

**Respeto al medio ambiente**

Refin utiliza materiales comunes en la naturaleza (principalmente arenas y arcillas), materiales reciclados y recupera el agua utilizada y el calor que de otra forma se dispersaría.

**100% reciclable**

El gres porcelánico es 100% reciclable y puede desecharse sin riesgo para el medio ambiente.

F

**VOUS POUVEZ AVOIR CONFIANCE DANS LA CÉRAMIQUE**

**Sûre**

Elle ne contient pas de substances toxiques (phtalates, formaldéhydes, solvants, adoucissants ou autres additifs chimiques). Elle n'émet pas de COV (composés organiques volatils), même en cas d'exposition à des températures élevées ou à la lumière directe du soleil. Elle est ignifuge et n'émet pas de fumée en cas d'incendie.

**Hygiénique**

Elle est hygiénique et facile à nettoyer dans tous les environnements. Elle favorise la qualité de l'air du fait qu'elle n'absorbe pas l'humidité ni les odeurs désagréables. Elle est anallergique et idéale en présence d'animaux domestiques.

**Made in Italy**

Le grès cérame Refin est produit intégralement en Italie, dans le respect des normes de protection de l'environnement et des travailleurs les plus strictes. Des contrôles de qualité soignés tout au long du processus de production protègent la santé et la sérénité des utilisateurs des produits en céramique.

D

**AUF KERAMIK KANN MAN SICH VERLASSEN**

**Sicher**

Sie enthält keine toxischen Substanzen (Phthalate, Formaldehyd, Lösungsmittel, Weichmacher oder andere chemischen Zusätze). Sie setzt auch bei hohen Temperaturen oder direkter Sonneneinstrahlung keine VOCs (flüchtige organische Substanzen) frei. Sie ist feuerfest und erzeugt im Brandfall keinen Rauch.

**Hygienisch**

Sie ist hygienisch und in jedem Raum leicht zu reinigen. Sie bewahrt die gute Luftqualität, da sie keine Feuchtigkeit und unangenehme Gerüche aufnimmt; sie ist hypoallergen und ideal bei Haustieren.

**Made in Italy**

Feinsteinzeug wird vollständig in Italien unter Einhaltung der strengsten Umwelt- und Gesundheitsschutznormen hergestellt. Genaue Qualitätskontrollen während des gesamten Produktionsprozesses schützen die Gesundheit und Sicherheit derjenigen, die Keramik verwenden.

N

**OP KERAMIEK KUN JE VERTROUWEN**

**Veilig**

Het bevat geen giftige stoffen (ftalaten, formaldehyde, oplosmiddelen, weekmakers of andere chemische additieven). Het geeft geen VOC (vluchtige organische stoffen) af, ook niet bij blootstelling aan hoge temperaturen of direct zonlicht. Het is onbrandbaar en geeft bij brand geen rook af.

**Hygiënisch**

Hygiënisch en gemakkelijk schoon te maken, in elke ruimte. Bevordert de luchtkwaliteit, want het neemt geen vocht of onaangename geuren op. Het is anallergeen en ideaal als er huisdieren aanwezig zijn.

**Made in Italy**

Porseleingres van Refin wordt volledig geproduceerd in Italië, met inachtneming van de strengste milieuregels en voorschriften inzake de gezondheid van werknemers. Nauwkeurige kwaliteitscontroles gedurende het hele productieproces beschermen de gezondheid en onbezorgdheid van degene die het keramiek gebruiken.

E

**SE PUEDE CONFIAR EN LA CERÁMICA**

**Segura**

No contiene sustancias tóxicas (ftalatos, formaldehído, disolventes, reblanecedores u otros aditivos químicos). No emite COV (compuestos orgánicos volátiles) incluso en caso de exposición a altas temperaturas o a la luz solar directa. Es ignífuga y no libera humos en caso de incendio.

**Higiénica**

Higiénica y fácil de limpiar en cualquier entorno. Favorece la calidad del aire al no absorber humedad ni olores desagradables. Es hipoalergénica e ideal cuando hay mascotas.

**Made in Italy**

El gres porcelánico Refin se produce íntegramente en Italia, de conformidad con las normas más estrictas de protección medioambiental y de salud de los trabajadores. Los controles de calidad minuciosos durante todo el proceso de producción protegen la salud y la tranquilidad de quienes usan la cerámica.

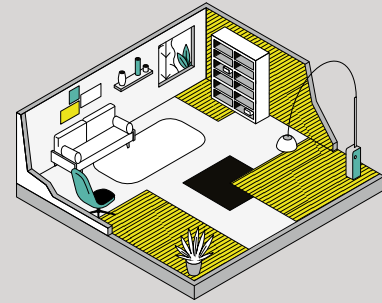

F

**LA CÉRAMIQUE EST AVANTAGEUSE**

**Résistante**

Le grès cérame est un matériau extrêmement résistant aux sollicitations, au piétinement et aux conditions climatiques les plus dures ainsi qu'aux attaques des produits chimiques d'entretien les plus répandus. Le grès ne se déforme pas et sa couleur, ses graphismes et sa structure ne s'altèrent pas. Le grès est imperméable et les variations thermiques ne l'endommagent pas.

**Rentable**

Le grès cérame dure longtemps. Grâce à son excellente conductibilité thermique, il est idéal pour des applications avec des systèmes de chauffage par le sol ou mural.

D

**KERAMIK IST WERTVOLL**

**Resistent**

Feinsteinzeug ist ein Material, das extrem widerstandsfähig ist und hohen Belastungen, starkem Verkehr und extremen Klimabedingungen sowie den gängigsten Reinigungsmitteln standhält. Feinsteinzeug verformt sich nicht, ist farbecht und behält sowohl Grafik als auch Oberflächenstruktur bei. Feinsteinzeug ist wasserdicht und scheut keine Temperaturschwankungen.

**Wirtschaftlich**

Feinsteinzeug weist eine lange Lebensdauer auf. Dank der hervorragenden Wärmeleitfähigkeit ist es ideal für den Einsatz mit Fußboden- oder Wandheizung.

N

**KERAMIEK IS WAARDEVOL**

**Duurzaam**

Porseleingres is een materiaal dat buitengewoon goed bestand is tegen belastingen, betreding en de meest extreme klimaatomstandigheden, alsook tegen aantasting door de meestgebruikte chemische reinigingsproducten. Gres vervormt niet, verandert niet van kleur, dessin of structuur. Gres is waterdicht en ondervindt geen schade door temperatuurvariaties.

**Voordelig**

Porseleingres is duurzaam. Het is ideaal om te worden gebruikt in situaties met vloer- of wandverwarming, dankzij de zeer goede warmtegeleiding.

E

**LA CERÁMICA VALE**

**Resistente**

El gres porcelánico es un material sumamente resistente al esfuerzo, al tránsito y a las condiciones climáticas más extremas, así como a los ataques de los productos químicos de limpieza más habituales. El gres no se deforma, no se altera su color, su diseño gráfico o su estructura. El gres es impermeable y no se daña ante los cambios de temperatura.

**Ventajoso**

El gres porcelánico dura mucho tiempo. Es ideal para ser aplicado con sistemas de calefacción de suelo o de pared, gracias a la excelente conductividad térmica.

F

**LA CÉRAMIQUE REFIN VOUS APPORTE DES ÉMOTIONS !**

**Belle**

Les consommateurs du monde entier préfèrent la céramique : plus de 60 % des sols sont réalisés avec ce matériau. Développés grâce à une combinaison spéciale de technique et de créativité, les graphismes Refin expriment la profondeur et l'aspect matériel et produisent des effets mat/brillant incomparables.

**Polyvalente**

Le grès cérame Refin remporte tous les suffrages car c'est un produit beau, durable, sûr, disponible dans une gamme de formats, d'épaisseurs, de finitions et de décorations presque infinie ainsi que dans des pièces spéciales adaptées à chaque exigence : il est idéal pour les espaces intérieurs et extérieurs, chauds ou froids, humides ou secs et pour les applications résidentielles, commerciales, publiques ou qui nécessitent des techniques particulières spécifiques.

D

**REFIN-KERAMIK BEGEISTERT !**

**Ansprechende Optik**

Verbraucher auf der ganzen Welt bevorzugen Keramik: Mehr als 60% der Bodenbeläge sind aus diesem Material gefertigt. Die grafischen Eigenschaften der Refin-Produkte vermitteln Tiefe und Stofflichkeit, sowie eine besondere matt-glänzende Optik, die durch eine spezielle Kombination von Technik und Kreativität entwickelt wurde.

**Vielseitig anwendbar**

Wer Refin-Feinsteinzeug wählt, verfügt über ein schönes, langlebiges und sicheres Produkt, das in einer nahezu unbegrenzten Auswahl an Formaten, Stärken, Oberflächen, Dekorationen und Formteilen erhältlich ist, die für jeden Bedarf spezifisch sind; es ist ideal für Innen- und Außenbereiche, Wärme oder Kälte, Nässe oder Trockenheit, sowie für Anwendungen im Wohnbereich, für kommerzielle, öffentliche oder andere Anwendungen, mit besonderen technischen Anforderungen.

N

**REFIN KERAMIEK ONTROERT !**

**Mooi**

Consumenten over de hele wereld geven de voorkeur aan keramiek: meer dan 60% van de vloeren worden gerealiseerd met dit materiaal. Refin dessins drukken diepte en textuur uit, en ongevenaarde mat/glanzende dekkingen die zijn ontwikkeld met een speciale combinatie van techniek en creativiteit.

**Veelzijdig**

Refin porseleingres krijgt de voorkeur omdat het een mooi, duurzaam, veilig product is, verkrijgbaar in een haast oneindig assortiment formaten, dikten, afwerkingen, decors, specifieke speciale onderdelen voor iedere behoefte; het is ideaal voor situaties binnen en buiten, warm of koud, vochtig of droog, en voor toepassingen in woonhuizen, winkels, openbare ruimten of ruimten waar specifieke bijzondere technieken nodig zijn.

E

**¡LA CERÁMICA REFIN EMOCIONA!**

**Bella**

Los consumidores de todo el mundo prefieren la cerámica: más del 60% de los suelos están hechos de este material. Los diseños gráficos de Refin expresan profundidad y textura, además de brindar un incomparable rendimiento mate/brillo desarrollado a través de una combinación especial de técnica y creatividad.

**Versátil**

Se prefiere el gres porcelánico Refin porque es un producto bello, duradero, seguro, disponible en una gama casi infinita de formatos, espesores, acabados, decoraciones, piezas especiales específicas para cualquier necesidad; es ideal para ambientes interiores y exteriores, cálidos o fríos, húmedos o secos y para aplicaciones residenciales, comerciales, públicas o que requieran de especificaciones técnicas particulares.



**Il gres porcellanato è un materiale inerte completamente riciclabile, che nasce da materie prime naturali la cui estrazione rispetta l'ambiente.**

Porcelain stoneware is a completely recyclable inert material. It comes from natural raw materials, the extraction of which respects the environment.

F

Le grès cérame nait de matières premières naturelles dont l'extraction respecte l'environnement. Le grès cérame est un matériau inerte entièrement recyclable.

D

Feinsteinzeug wird aus natürlichen Rohstoffen hergestellt, deren Gewinnung umweltfreundlich ist. Feinsteinzeug ist ein vollständig recycelbares, inertes Material.

N

Porseleingres wordt gemaakt uit natuurlijke grondstoffen die worden gewonnen met respect voor het milieu. Porseleingres is een volledig recyclebaar, inert materiaal.

E

El gres porcelánico surge de materias primas naturales cuya extracción respeta el medio ambiente. El gres porcelánico es un material inerte totalmente reciclable.



---

Artech	18
Avantgarde	24
Baita	30
Block	34
Blue Emotion	40
Bluetech	46
Bricklane	50
Chevron	56
Creos	62
Cromie	68
Deck	76
Design Industry	82
Epoque	88
Essence	96
Flake	104
Foil	110
Fornace	116
Fusion	124
Gaja	130
Giant	136
Graffiti	142
Grecale	150
Kasai	160
Larix	176
Mansion	182
Mold	186
Petrae	192
Pietra di Cembra	200
Pietre di Borgogna	210
Plain	216
Plant	224
Poesia	230
Prestigio	238
Risseu	262
Stardust	268
Trail	276
Tune	282
Urbex Style	290
Vetri	298
Wide	306



## Hi-Tech revolution

Artech è la collezione innovativa, nata per ambienti moderni e raffinati, come loft e show room. Grazie allo straordinario effetto luminescente, permette di realizzare superfici tecnologiche, molto simili al metallo, ma più inalterabili e di facile manutenzione. Una scelta completa tra soluzioni multiformato per interni, pezzi speciali e battiscopa per attente finiture di pregio.

Artech is an innovative collection for elegant, modern interiors such as lofts and showrooms. Its extraordinary luminescence allows for the creation of hi-tech surfaces very similar to metal, but more durable and easy to maintain. There is a complete choice of indoor multisize solutions, trim tiles and baseboards for top-class detailed finishings.

Artech est une collection innovante, née pour les environnements modernes et raffinés, tels que les lofts et les showrooms. Grâce à son extraordinaire effet luminescent, Artech permet de réaliser des surfaces spéciales très similaires au métal mais plus inaltérables et faciles à entretenir. Une gamme de choix complète allant des solutions multiformat pour les intérieurs, aux pièces spéciales et plinthes pour la réalisation de finitions soignées et de valeur.

Artech ist eine innovative Kollektion, die für moderne und raffinierte Umgebungen, wie lofts und showrooms zusammengestellt wurde. Dank dem außergewöhnlichen Leuchteffekt können technische Oberflächen realisiert werden, die stark dem Metal ähneln, doch leicht zu pflegen sind und sich durch eine erstklassige Beständigkeit auszeichnen. Ein umfassendes Angebot an mehrformatigen Lösungen für Innenbereiche, Formteilen und Leisten für eine besonders sorgfältige Verarbeitung.

Artech is de innovatieve collectie, ontstaan voor moderne en geraffineerde interieurs, zoals lofts en showrooms. Dankzij het buitengewone lichtuitstralende effect, kunnen technologische oppervlakken gerealiseerd worden, die zeer op metaal lijken, maar meer onveranderlijk en makkelijk te onderhouden zijn. Een complete keuze uit multiformaat oplossingen voor interieur, speciale artikelen en plinten voor een minutieuze en verfijnde afwerking.

Artech es la colección innovadora creada para ambientes modernos y refinados como loft y show room. Gracias al extraordinario efecto luminoso permite que se realicen superficies tecnológicas muy parecidas al metal, pero más inalterables y de fácil mantenimiento. Una elección completa entre soluciones multiformato para interiores, elementos especiales y rodapiés para unos refinados acabados de calidad.

9 mm

60x60/24"x24" R  
30x60/12"x24" R

9,5 mm

45x45/18"x18"

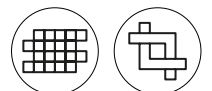

Fondi/Plain Tiles/Fonds/  
Grundfliesen/Fondsen/Fondos



**Bianco** 60x60/24"x24" R IS18  
30x60/12"x24" R NE00  
45x45/18"x18" H710



**Perlato** 60x60/24"x24" R IS21  
30x60/12"x24" R NE04  
45x45/18"x18" H717



**Grigio** 60x60/24"x24" R IS19  
30x60/12"x24" R NE02  
45x45/18"x18" H712



**Nero** 60x60/24"x24" R IS20  
30x60/12"x24" R NE06  
45x45/18"x18" H713



**Beige** 60x60/24"x24" R IS17  
30x60/12"x24" R ND98  
45x45/18"x18" H711

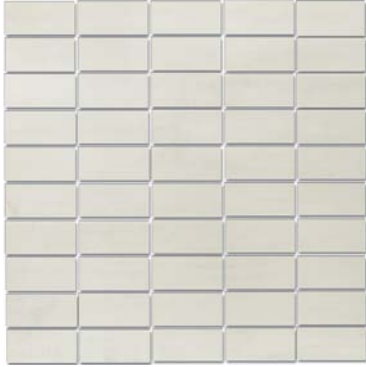

**Bianco** 30x30/12"x12" R  
Mosaico

H966



**Perlato** 30x30/12"x12" R  
Mosaico

H969

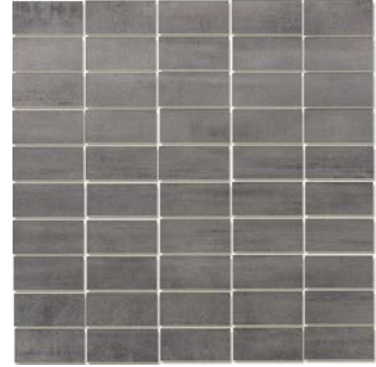

**Grigio** 30x30/12"x12" R  
Mosaico

H967



**Nero** 30x30/12"x12" R  
Mosaico

H968



**Beige** 30x30/12"x12" R  
Mosaico

H965

## Pezzi speciali/Trim tiles/Pieces speciales/Formteile/Speciale delen/Piezas especiales



### Battiscopa

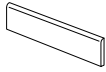

**10x60/4"x24" R**

Beige **IA69**  
 Bianco **IP82**  
 Grigio **HL85**  
 Nero **IP83**  
 Perlato **IO08**

**8,5x45/3<sup>1</sup>/<sub>2</sub>"x18"**

Beige **H888**  
 Bianco **H889**  
 Grigio **H890**  
 Nero **H891**  
 Perlato **H892**

### Gradino Industriale

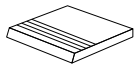

**30x60/12"x24"**

Beige **HL03**  
 Bianco **HL04**  
 Grigio **HL05**  
 Nero **HL06**  
 Perlato **HL07**

**45x45/18"x18"**

Beige **HL13**  
 Bianco **HL14**  
 Grigio **HL15**  
 Nero **HL16**  
 Perlato **HL17**

## Caratteristiche/Features/Caracteristiques/Eigenschaften/Eigenschappen/Características



UNI EN ISO 10545/14



B.C.R.A. Rep. CEC/81



ANSI A137.1-2012 (BOT3000)

Classe 5 / Class 5

Asciutto > 0,40 / Bagnato > 0,40 > 0,42 Wet

Imballi/Packing/Emballage/Verpackungseinheiten/Verpakking/Embalajes

	pcs x box	m <sup>2</sup> / m x box	kg x box	box x pallet	m <sup>2</sup> x pallet	kg x pallet
60x60/24"x24"	3	1,0800	21,35	40	43,20	854,00
30x60/12"x24"	7	1,2600	25,00	40	50,40	1000,00
45x45/18"x18"	5	1,0125	20,60	33	33,41	679,80
30x30/12"x12" Mosaico	11	0,9900	20,60	18	17,82	370,80
10x60/4"x24" Battiscopa	10	6,0000	11,50	60	360,00	690,00
8,5x45/3 <sup>1/2</sup> "x18" Battiscopa	8	3,6000	6,50	69	248,40	448,50
30x60/12"x24" Gradino Industriale	6	1,0800	24,00	40	43,20	960,00
45x45/18"x18" Gradino Industriale	5	1,0125	20,60	40	40,50	824,00

Nero 45x45/18"x18"





Glace 45x45/18"x18"



## Classic elegance

---

Una collezione completa per interpretare tutte le esigenze: dai pavimenti interni ed esterni, ai rivestimenti cucina e bagno.

A complete collection to satisfy all requirements: from interior and exterior floors to kitchen and bathroom tiles.

Une collection complète pour interpréter toutes les exigences: des sols, intérieurs et extérieurs, aux revêtements muraux pour cuisines et salles de bain.

Eine komplette Kollektion, um allen Anforderungen gerecht zu werden: von innen- und aussenböden, bis wandverkleidungen für küche und bad.

Een complete collectie die alle behoeften weet te interpreteren: van binnen- en buitenvloeren tot en met de bekleding van keuken en badkamer.

Una colección completa por interpretar todas las necesidades: desde los pavimentos interiores y exteriores, a los revestimientos de cocina y baño.

✂ 9 mm

60x60/24"x24" R  
30x60/12"x24" R  
30x30/12"x12"

✂ 9,5 mm

45x45/18"x18"



Gres porcellanato  
Porcelain stoneware  
Grès cérame fin vitrifié  
Feinsteinzeug  
Porseleingres  
Gres porcelánico

Fondi/Plain Tiles/Fonds/  
Grundfliesen/Fondsen/Fondos



**Blanc** 60x60/24"x24" R IS25  
30x60/12"x24" R NE39  
45x45/18"x18" H306  
30x30/12"x12" NG65



**Glace** 60x60/24"x24" R IS28  
30x60/12"x24" R NE42  
45x45/18"x18" H239  
30x30/12"x12" NG68



**Kevlar** 60x60/24"x24" R IS29  
30x60/12"x24" R NE43  
45x45/18"x18" H240  
30x30/12"x12" NG69



**Creme** 60x60/24"x24" R IS27  
30x60/12"x24" R NE41  
45x45/18"x18" H242  
30x30/12"x12" NG67



**Coco** 60x60/24"x24" R IS26  
30x60/12"x24" R NE40  
45x45/18"x18" H263  
30x30/12"x12" NG66



**Savane** 60x60/24"x24" R IS30  
30x60/12"x24" R NE44  
45x45/18"x18" H241  
30x30/12"x12" NG70



## Pezzi speciali/Trim tiles/Pieces speciales/Formteile/Speciale delen/Piezas especiales



### Battiscopa

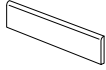

10x60/4"x24" R

Blanc	<b>MT90</b>
Coco	<b>GN28</b>
Creme	<b>MU50</b>
Glace	<b>L433</b>
Kevlar	<b>MU51</b>
Savane	<b>L432</b>

8,5x45/3<sup>1</sup>/<sub>2</sub>"x18"

Blanc	<b>H384</b>
Coco	<b>H385</b>
Creme	<b>H386</b>
Glace	<b>H387</b>
Kevlar	<b>H388</b>
Savane	<b>H389</b>

### Gradino Industriale

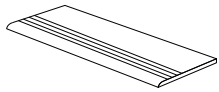

30x60/12"x24"

Blanc	<b>HL56</b>
Coco	<b>HL57</b>
Creme	<b>HL58</b>
Glace	<b>HL59</b>
Kevlar	<b>HL60</b>
Savane	<b>HL61</b>

### Gradino Industriale

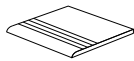

45x45/18"x18"

Blanc	<b>HL46</b>
Coco	<b>HL47</b>
Creme	<b>HL48</b>
Glace	<b>HL49</b>
Kevlar	<b>HL50</b>
Savane	<b>HL51</b>

30x30/12"x12"

Blanc	<b>HL66</b>
Coco	<b>HL67</b>
Creme	<b>HE26</b>
Glace	<b>HL69</b>
Kevlar	<b>HL70</b>
Savane	<b>HL71</b>

## Caratteristiche/Features/Caracteristiques/Eigenschaften/Eigenschappen/Características



UNI EN ISO 10545/14

Classe 5 / Class 5



DIN 51130

R9



B.C.R.A. Rep. CEC/81

Asciutto > 0,40 / Bagnato > 0,40



ANSI A137.1-2012 (BOT3000)

> 0,42 Wet

Imballi/Packing/Emballage/Verpackungseinheiten/Verpakking/Embalajes

	pcs x box	m <sup>2</sup> / m x box	kg x box	box x pallet	m <sup>2</sup> x pallet	kg x pallet
60x60/24"x24"	3	1,0800	21,35	40	43,20	854,00
30x60/12"x24"	7	1,2600	25,00	40	50,40	1000,00
45x45/18"x18"	5	1,0125	20,60	33	33,41	679,80
30x30/12"x12"	12	1,0800	20,50	48	51,84	984,00
10x60/4"x24" Battiscopa	10	6,0000	11,50	60	360,00	690,00
8,5x45/3 <sup>1/2</sup> "x18" Battiscopa	8	3,6000	6,50	69	248,40	448,50
30x60/12"x24" Gradino Industriale	6	1,0800	24,00	40	43,20	960,00
45x45/18"x18" Gradino Industriale	5	1,0125	20,60	40	40,50	824,00
30x30/12"x12" Gradino Industriale	15	1,3500	25,00	40	54,00	1000,00

Savane 30x30/12"x12"





## Alpine charme

Baita trae ispirazione dalle tipiche Stube, le stanze completamente rivestite in legno caratteristiche delle case alpine, dove protagonista era la stufa. Il riferimento è confermato dalla scelta delle particolari varianti cromatiche che riproducono gli stadi di maturazione del legno di larice, sempre diverso a causa del proprio ciclo di vita e degli agenti atmosferici. Le tonalità suggeriscono così l'essenza del legname appena tagliato (Fresh), le sfumature assunte quando utilizzato all'interno (Natural) e quando posizionato in esterno, se esposto alla luce diretta del sole (Sun) oppure in zone d'ombra (Shade). Baita è disponibile nel formato 60x60 cm.

Baita takes its inspiration from the characteristic Stube, the parlours with fully wood-panelled walls typical of homes in the Alps, where the stove had a central role to play. This inspiration is evident in the choice of the particular nuances that mimic the various degrees of aging of larch wood, never the same twice as a result of the life cycle of the tree and the weather conditions of the environment. The shades available are thus reminiscent of the freshly cut wood (Fresh), the nuances it takes on when used inside (Natural) and when placed outdoors and exposed to direct sunlight (Sun) or in the shade (Shade). Baita comes in the 60x60 cm size.

Baita puise son inspiration des typiques Stube, les pièces entièrement revêtues de bois, caractéristiques des maisons alpines, où le protagoniste était le poêle. La référence est confirmée par le choix de variantes chromatiques particulières qui reproduisent les stades de maturation du bois mélèze, toujours différent en raison de son cycle de vie et des agents atmosphériques. Les tonalités suggèrent ainsi l'essence du bois fraîchement coupé (Fresh), ses nuances acquises une fois utilisé à l'intérieur (Natural) et placé en extérieur, exposé à la lumière du soleil (Sun) ou dans des zones d'ombre (Shade). Baita est proposé dans le format 60x60 cm.

Die Inspiration für Baita stammt von den typischen Stuben, für den Alpenraum typischen Zimmern, die komplett mit Holz verkleidet sind und deren Mittelpunkt der Ofen darstellt. Die Bezugnahme darauf wird auch durch die Wahl der besonderen Farbvarianten bestätigt, die die Reifungsphasen von Lärchenholz wiedergeben, das aufgrund seines Lebenszyklus und der Witterung immer unterschiedlich wirkt. Die Farbtöne erinnern daher an das Holz von frischgefallten Stämmen (Fresh), die Nuancen, die das Holz durch die Verwendung in Innenräumen (Natural) bzw. im Außenbereich, wenn es dem direkten Sonnenlicht ausgesetzt wird (Sun) oder sich im Schatten befindet (Shade), annimmt. Baita wird im Format 60x60 cm angeboten.

Baita inspireert zich aan de Stube, de volledig in hout beklede kamers met centrale kachel die typisch zijn voor de berghuisjes uit de Alpen. Het kracht van de collectie wordt versterkt door de bijzondere kleurvarianties die de verschillende rijpingsstadia reproduceren van larikshout, dat door zijn levenscyclus en de inwerking van atmosferische invloeden er steeds weer anders uitziet. De tinten uit de collectie verwijzen naar vers gesneden hout (Fresh), de houtnuances bij plaatsing binnenhuis (Natural) en buitenhuis in direct zonlicht (Sun) of in schaduwzones (Shade). Baita is beschikbaar in het formaat 60x60 cm.

Baita toma su inspiración de las típicas Stube, las estancias completamente revestidas de madera típicas de las casas alpinas en las que la estufa era la protagonista. Esta referencia se confirma por las variaciones cromáticas tan particulares que reproducen los diferentes estados de maduración de la madera de alerce, que cambia por su propio ciclo de vida y por los agentes atmosféricos. Los tonos evocan por tanto la esencia de la madera recién cortada (Fresh), los matices adoptados cuando se utiliza en el interior (Natural), y en el exterior, si está expuesta a la luz directa del sol (Sun) o en la sombra (Shade). Baita está disponible en el formato 60x60cm.

✂ 9 mm

60x60/24"x24"R

Gres porcellanato  
Porcelain stoneware  
Grès cérame fin vitrifié  
Feinsteinzeug  
Porseleingres  
Gres porcelánico



Fondi/Plain Tiles/Fonds/  
Grundfliesen/Fondsen/Fondos

V3  
Moderate



Natural 60x60/24"x24" R LQ25



Fresh 60x60/24"x24" R LQ26



Sun 60x60/24"x24" R LQ28

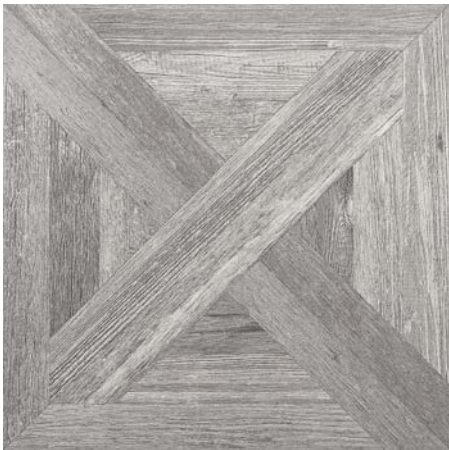

Shade 60x60/24"x24" R LQ27

Imballi/Packing/Emballage/Verpackungseinheiten/Verpakking/Embalajes

	pcs x box	m <sup>2</sup> / m x box	kg x box	box x pallet	m <sup>2</sup> x pallet	kg x pallet
60x60/24"x24"	3	1,0800	21,35	40	43,20	854,00



Fresh 60x60/24"x24" R

Caratteristiche/Features/Caracteristiques/Eigenschaften/Eigenschappen/Características



UNI EN ISO 10545/14

Classe 5 / Class 5



DIN 51130

R10



BS 7976-2:2002  
(CEN/TS 16165, Annex C)  
Pendulum Friction Test

≥ 36 Wet



B.C.R.A. Rep. CEC/81

Asciutto > 0,40 / Bagnato > 0,40



ANSI A137.1-2012 (BOT3000)

> 0,42 Wet

Cinder 120×120/48"×48" R — Iron 120×120/48"×48" R



## Molten stone

Block trae ispirazione dal cemento nella forma che esteticamente più si avvicina agli elementi naturali che lo compongono: pietra, argilla e calce. Pietrisco e sassi di diverse dimensioni emergono in superficie, come avvolti dal cemento allo stato semiliquido. Proposta nel colore bianco Mist, e in tre nuance di grigio, Cinder il chiaro, Iron lo scuro e Nickel tendente al fango, Block è disponibile nei formati 120x120, 60x120, 75x150, 75x75, 60x60 e 30x60, sia in finitura matt che in finitura soft, dalla mano morbida e piacevole al tatto.

Block draws inspiration from concrete in the form closest to the natural elements it is made of: rock, clay and limestone. Gravel and rocks of varying coarseness emerge to the surface, as if immersed in concrete in a semi-liquid state. Produced in Mist white and three shades of grey - light Cinder, dark Iron and muddy Nickel - Block is available in the 120x120, 60x120, 75x150, 75x75, 60x60 and 30x60 formats, either with a matt or Soft R finish, with a soft hand and a very pleasant tactile texture.

Block s'inspire du ciment sous sa, sur le plan esthétique, qui s'approche le plus aux éléments naturels qui le composent : pierre, chaux et argile. Des pierres et des blocailles de différentes dimensions émergent sur sa surface, comme enveloppés par du ciment à l'état semi-liquide. Proposée dans le coloris blanc Mist, et dans trois tonalités de gris, le gris clair Cinder, le gris foncé Iron, et Nickel, un gris qui tend vers la couleur argile, la collection Block est disponible aux formats 120x120, 60x120, 75x150, 75x75, 60x60 et 30x60, soit en finition mate que dans une finition soft, douce et agréable au toucher.

Block ist am Zement in jener Art inspiriert, die sich am meisten den Naturelementen nähert, aus denen er sich zusammensetzt: Stein, Ton und Kalk. Schotter und Steine verschiedener Größen treten an der Oberfläche zum Vorschein, als wären sie in halbflüssigem Zustand vom Zement umhüllt. In der Farbe Weiß Mist und in drei Graunüancen, Cinder hell, Iron dunkel und Nickel mit Tendenz zur Fangfarbe vorgestellt, ist Block in den Formaten 120x120, 60x120, 75x150, 75x75, 60x60 und 30x60 verfügbar, sowohl in matter Endausführung als auch in der weichen und sich angenehm anführenden Soft-Version.

Block is geïnspireerd op beton in de vorm die esthetisch het meest lijkt op de natuurlijke elementen waaruit het is opgebouwd: steen, klei en kalk. Grind en stenen van verschillende afmetingen komen aan het oppervlak, alsof ze in halfvloeibaar beton zijn gewikkeld. Block is verkrijgbaar in de witte kleur Mist en in drie grijs tinten: Cinder (lichtgrijs), Iron (donker-grijs) en Nickel, dat neigt naar modderkleurig. Het is verkrijgbaar in de afmetingen: 120x120, 60x120, 75x150, 75x75, 60x60 en 30x60, zowel met matte als zachte afwerking, zodat hij zacht en prettig aanvoelt.

La colección Block se inspira en el cemento en la forma estética más auténtica de los elementos naturales que lo componen: la piedra, la arcilla y la cal. En la superficie emergen la grava y las piedras de diferentes tamaños, como si estuvieran envueltas por el cemento en un estado semilíquido. Propuesta en el color blanco Mist, y en tres tonalidades de grises, Cinder el claro, Iron el oscuro y Nickel que tiende al lodo, Block está disponible en los formatos 120x120, 60x120, 75x150, 75x75, 60x60 y 30x60, tanto en el acabado matt como en el acabado soft, de textura aterciopelada y suave al tacto.

± 9 mm

120x120/48"x48" R  
120x120/48"x48" Soft R  
60x120/24"x48" R  
60x120/24"x48" Soft R  
75x150/30"x60" R  
75x150/30"x60" Soft R  
75x75/30"x30" R  
75x75/30"x30" Soft R  
60x60/24"x24" R  
60x60/24"x24" Soft R  
30x60/12"x24" R  
30x60/12"x24" Soft R

± 20 mm OUT2.0

90x90/36"x36" R

Gres porcellanato  
Porcelain stoneware  
Grès cérame fin vitrifié  
Feinsteinzeug  
Porseleingres  
Gres porcelánico



V3  
Moderate

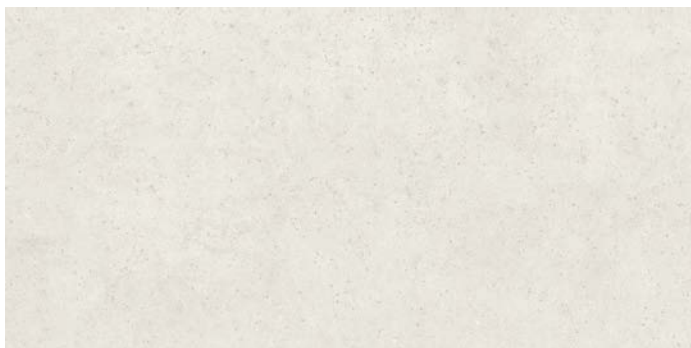
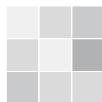

<b>Mist</b>	<b>120x120/48"x48" R</b>	<b>MY58</b>
	<b>120x120/48"x48" Soft R</b>	<b>BY59</b>
	<b>60x120/24"x48" R</b>	<b>NC86</b>
	<b>60x120/24"x48" Soft R</b>	<b>NC87</b>
	<b>75x150/30"x60" R</b>	<b>MW45</b>
	<b>75x150/30"x60" Soft R</b>	<b>MW50</b>
	<b>75x75/30"x30" R</b>	<b>MX89</b>
	<b>75x75/30"x30" Soft R</b>	<b>MX90</b>
	<b>60x60/24"x24" R</b>	<b>MX50</b>
	<b>60x60/24"x24" Soft R</b>	<b>MX51</b>
	<b>30x60/12"x24" R</b>	<b>MX26</b>
	<b>30x60/12"x24" Soft R</b>	<b>MX27</b>

<b>Cinder</b>	<b>120x120/48"x48" R</b>	<b>MY54</b>
	<b>120x120/48"x48" Soft R</b>	<b>MY55</b>
	<b>60x120/24"x48" R</b>	<b>NC82</b>
	<b>60x120/24"x48" Soft R</b>	<b>NC83</b>
	<b>75x150/30"x60" R</b>	<b>MW43</b>
	<b>75x150/30"x60" Soft R</b>	<b>MW48</b>
	<b>75x75/30"x30" R</b>	<b>MX85</b>
	<b>75x75/30"x30" Soft R</b>	<b>MX86</b>
	<b>60x60/24"x24" R</b>	<b>MX46</b>
	<b>60x60/24"x24" Soft R</b>	<b>MX47</b>
	<b>30x60/12"x24" R</b>	<b>MX22</b>
	<b>30x60/12"x24" Soft R</b>	<b>MX23</b>
	<b>90x90/36"x36" R</b>	<b>OUT2.0</b>
		<b>MJ95</b>

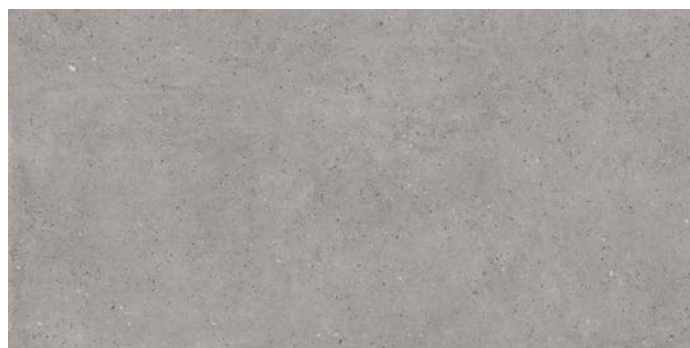

<b>Iron</b>	<b>120x120/48"x48" R</b>	<b>MY56</b>
	<b>120x120/48"x48" Soft R</b>	<b>MY57</b>
	<b>60x120/24"x48" R</b>	<b>NC84</b>
	<b>60x120/24"x48" Soft R</b>	<b>NC85</b>
	<b>75x150/30"x60" R</b>	<b>MW44</b>
	<b>75x150/30"x60" Soft R</b>	<b>MW49</b>
	<b>75x75/30"x30" R</b>	<b>MX87</b>
	<b>75x75/30"x30" Soft R</b>	<b>MX88</b>
	<b>60x60/24"x24" R</b>	<b>MX48</b>
	<b>60x60/24"x24" Soft R</b>	<b>MX49</b>
	<b>30x60/12"x24" R</b>	<b>MX24</b>
	<b>30x60/12"x24" Soft R</b>	<b>MX25</b>

<b>Nickel</b>	<b>120x120/48"x48" R</b>	<b>MY60</b>
	<b>120x120/48"x48" Soft R</b>	<b>MY61</b>
	<b>60x120/24"x48" R</b>	<b>NC88</b>
	<b>60x120/24"x48" Soft R</b>	<b>NC89</b>
	<b>75x150/30"x60" R</b>	<b>MW46</b>
	<b>75x150/30"x60" Soft R</b>	<b>MW51</b>
	<b>75x75/30"x30" R</b>	<b>MX91</b>
	<b>75x75/30"x30" Soft R</b>	<b>MX92</b>
	<b>60x60/24"x24" R</b>	<b>MX52</b>
	<b>60x60/24"x24" Soft R</b>	<b>MX53</b>
	<b>30x60/12"x24" R</b>	<b>MX28</b>
	<b>30x60/12"x24" Soft R</b>	<b>MX29</b>

Nickel 75x150/30"x60" Soft R

Block  
36/37



## Pezzi speciali/Trim tiles/Pieces speciales/Formteile/Speciale delen/Piezas especiales

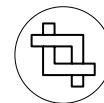

### Battiscopa

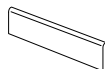

7x75/2<sup>7/8</sup>"x30" R

Cinder  
Iron  
Mist  
Nickel

**MX04**  
**MX05**  
**MX06**  
**MX07**

7x60/2<sup>7/8</sup>"x24" R

Cinder  
Iron  
Mist  
Nickel

**MW92**  
**MW93**  
**MW94**  
**MW95**

## Imballi/Packing/Emballage/Verpackungseinheiten/Verpakking/Embalajes

	pcs x box	m <sup>2</sup> / m x box	kg x box	box x pallet	m <sup>2</sup> x pallet	kg x pallet
120x120/48"x48"	2	2,8800	58,00	20	57,60	1160,00
60x120/24"x48"	2	1,4400	31,50	35	50,40	1102,50
75x150/30"x60"	1	1,1250	24,50	25	28,13	612,50
75x75/30"x30"	2	1,1250	24,00	42	47,25	1008,00
60x60/24"x24"	3	1,0800	21,35	40	43,20	854,00
30x60/12"x24"	7	1,2600	25,00	40	50,40	1000,00
90x90/36"x36" <b>OUT2.0</b>	1	0,8100	37,60	18	14,58	676,80
7x75/2 <sup>7/8</sup> "x33" Battiscopa	10	7,5000	11,00	54	405,00	594,00
7x60/2 <sup>7/8</sup> "x24" Battiscopa	10	6,0000	9,00	70	420,00	630,00

The MATT and SOFT finishes are recommended for interior floors, walls, and exterior walls in both residential and commercial applications. Block is not recommended for exterior horizontal surfaces or exterior paving, and they are not recommended for ramps application. The SOFT finish is not recommended for interior floors in entrance areas if joined to outdoor in commercial applications.

## SOFT Caratteristiche/Features/Caracteristiques/Eigenschaften/Eigenshappen/Características



UNI EN ISO 10545/14

Classe 5 / Class 5



B.C.R.A. Rep. CEC/81

Asciutto > 0,40 /  
Bagnato > 0,40



ANSI A137.1-2012 (BOT3000)

> 0,42 Wet

## MATT Caratteristiche/Features/Caracteristiques/Eigenschaften/Eigenshappen/Características



UNI EN ISO 10545/14

Classe 5 / Class 5



DIN 51130

R10  
R11 OUT2.0



DIN 51097

A+B  
A+B+C OUT2.0



BS 7976-2:2002  
(CEN/TS 16165, Annex C)  
Pendulum Friction Test

≥ 36 Wet



B.C.R.A. Rep. CEC/81

Asciutto > 0,40 /  
Bagnato > 0,40



ANSI A137.1-2012 (BOT3000)

> 0,42 Wet

Cinder 75x75/30"x30" Soft R





Scié Grey 60x60/24"x24" R — Scié Dark 60x60/24"x24" R



## Dark elegance

Una collezione ispirata ai toni intensi e dark della Pierre Bleue di origine belga, le cui diverse lavorazioni creano due differenti superfici dall'appeal esclusivo. Scié reinterpreta la superficie liscia generata dal taglio della pietra, caratterizzata dalle tracce lasciate dalle lame e da bande di nuances differenti. Flammé rappresenta la particolare finitura fiammata e caratterizzata da sfumature di grigi scuri-quasi neri, che la pietra naturale assume quando trattata con fonti di calore intenso.

A collection inspired by the dark and vivid hues of the Belgian Bluestone, whose different machining generates two uniquely appealing surfaces. Scié is a new interpretation of the smooth surface of a cut stone, featuring the marks left by the blades and differently coloured strips. Flammé is a flambé finish with dark grey, almost black hues, the ones of a highly heated natural stone.

Une collection inspirée des nuances intenses et profondes de la Pierre Bleue d'origine Belge dont les différents usinages créent deux surfaces à l'allure exclusive. Scié revisite la surface lisse résultant de la pierre coupée, caractérisée par les traces du passage des lames et par des bandes nuancées différemment. Flammé propose une finition flambée aux nuances gris foncé, presque noir, celles développées par la pierre naturelle lorsqu'elle est soumise à une chaleur élevée.

Kollektion, die sich von den intensiven dunklen Farbtönen der belgischen Pierre Bleue inspirieren lässt, deren verschiedenen Bearbeitungen zwei unterschiedliche und extrem attraktiven Oberflächen schaffen. Scié bietet eine neue Interpretation der glatten Oberfläche des Steinschnitts, die durch die Klingenspuren und Streifen unterschiedlicher Nuancen gekennzeichnet ist. Flammé stellt die besondere flammierte Feinbearbeitung dar, welche von den dunkelgrauen und fast schwarzen Farbtönen des natürlichen Steins charakterisiert ist, nachdem dieser einer starken Hitze unterworfen worden ist.

Een collectie geïnspireerd op de intense, duistere nuances van de Belgische Pierre Bleue, die met zijn verschillende bewerkingen twee verschillende oppervlakken met een exclusief appeal creëert. Scié herinterpreteert het gladde oppervlak dat door het zagen van de steen ontstaat, met zaagsporen en strepen in verschillende nuances. Flammé toont de bijzondere gevlamde afwerking met schakeringen van donkergrijs tot bijna zwart, die deze steen door behandelingen met hittebronnen krijgt.

Una colección inspirada en los tonos intensos y oscuros de la Pierre Bleue de origen belga, cuyas diferentes elaboraciones producen dos superficies distintas con un atractivo único. Scié reinterpreta la superficie lisa dada por el corte de la piedra, caracterizada por las huellas dejadas por las cuchillas y por bandas de diferentes tonalidades. Flammé cuenta con el especial acabado flameado caracterizado por matices de grises oscuros-casi negros que la piedra natural cobra al ser tratada con fuentes de calor intenso.

✂ 9 mm

45x90/18"x36" R  
60x60/24"x24" R  
30x60/12"x24" R

✂ 20 mm OUT2.0

40x120/16"x48" R  
90x90/36"x36" R  
60x90/24"x36" R  
60x60/24"x24" R

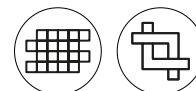

V3  
Moderate \*



V4  
Substantial



**Scié  
Light**      **45x90/18"x36" R**      **ME61**  
**60x60/24"x24" R**      **ME38**  
**30x60/12"x24" R**      **NF12**



**Scié  
Grey**      **45x90/18"x36" R**      **ME60**  
**60x60/24"x24" R**      **ME37**  
**30x60/12"x24" R**      **NF13**  
**60x60/24"x24" R OUT2.0**      **ME39**



**Scié  
Dark**      **45x90/18"x36" R**      **ME59**  
**60x60/24"x24" R**      **ME36**  
**30x60/12"x24" R**      **NF14**



**Flammé  
Grey \***      **45x90/18"x36" R**      **MF66**  
**60x60/24"x24" R**      **ME04**  
**60x60/24"x24" R OUT2.0**      **MC56**



**Flammé  
Blue \***      **45x90/18"x36" R**      **MF67**  
**60x60/24"x24" R**      **ME03**  
**40x120/16"x48" R OUT2.0**      **MI48**  
**90x90/36"x36" R OUT2.0**      **MT63**  
**60x90/24"x36" R OUT2.0**      **NH58**  
**60x60/24"x24" R OUT2.0**      **MC55**



V3  
Moderate \*



V4  
Substantial



Scié  
Light  
Mosaico  
30x30/12"x12" R MG76



Scié  
Grey  
Mosaico  
30x30/12"x12" R MG75



Scié  
Dark  
Mosaico  
30x30/12"x12" R MG74

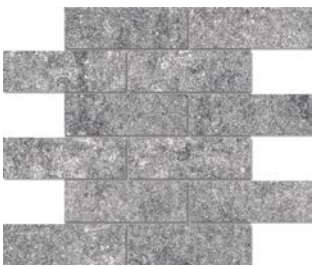

Flammé  
Grey\*  
Mosaico  
30x30/12"x12" R MG73



Flammé  
Blue\*  
Mosaico  
30x30/12"x12" R MG72

## Pezzi speciali/Trim tiles/Pieces speciales/Formteile/Speciala delen/Piezas especiales



### Battiscopa

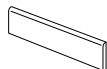

7x60/2<sup>7/8</sup>"x24" R

Flammé Blue	<b>MF02</b>
Flammé Grey	<b>MF01</b>
Scié Dark	<b>MF00</b>
Scié Grey	<b>ME99</b>
Scié Light	<b>ME98</b>

## Imballi/Packing/Emballage/Verpackungseinheiten/Verpakking/Embalajes

	pcs x box	m <sup>2</sup> / m x box	kg x box	box x pallet	m <sup>2</sup> x pallet	kg x pallet
45x90/18"x36"	3	1,2150	25,80	36	43,74	928,80
60x60/24"x24"	3	1,0800	21,35	40	43,20	854,00
30x60/12"x24"	7	1,2600	25,00	40	50,40	1000,00
40x120/16"x48" <b>OUT2.0</b>	2	0,9600	41,50	24	23,04	996,00
90x90/36"x36" <b>OUT2.0</b>	1	0,8100	37,60	18	14,58	676,80
60x90/24"x36" <b>OUT2.0</b>	2	1,0800	48,50	18	19,44	873,00
60x60/24"x24" <b>OUT2.0</b>	2	0,7200	32,40	30	21,60	972,00
30x30/12"x12" Mosaico	11	0,9900	20,60	18	17,82	370,80
7x60/2 <sup>7/8</sup> "x24" Battiscopa	10	6,0000	9,00	70	420,00	630,00

## Caratteristiche/Features/Caracteristiques/Eigenschaften/Eigenschappen/Características



UNI EN ISO 10545/14



DIN 51130



DIN 51097



B.C.R.A. Rep. CEC/81



ANSI A137.1-2012 (BOT3000)

Classe 5 / Class 5

R9 Scié  
R10 Flammé  
R11 OUT2.0

A+B Flammé  
A+B+C OUT2.0

Asciutto > 0,40 / Bagnato > 0,40 > 0,42 Wet





## Tradition and innovation

Il pregio e l'eleganza della Pierre Bleue del Belgio rivivono nelle ceramiche Refin in una collezione dal contenuto altamente innovativo, espressione delle più avanzate tecnologie produttive coniugate all'esperienza e alla cultura ceramica che da sempre contraddistinguono il grès porcellanato Refin.

The appeal and elegance of the Belgian Pierre Bleue are brought up-to-date in this ceramic collection by Ceramiche Refin, a series with an extremely innovative make-up and appearance, the result of the most advanced production technologies combined with the experience and know-how typical of Refin porcelain stoneware tiles.

La réputation et l'élégance de la Pierre Bleue de Belgique revivent avec Ceramiche Refin dans une collection au contenu hautement innovateur, expression de la technologie productive la plus avancée conjuguée à l'expérience et à la culture céramique qui depuis toujours caractérisent le Grès Fin Vitrifié Refin.

Der Wert und die Eleganz des belgisches Blaustein werden in einer stark innovativen Kollektion der Refin Keramik wieder lebendig, sie verkörpert und symbolisiert die perfekte Kombination aus der Herstellungserfahrung und der Innovationskapazität, die die Refins Feinsteinzeug immer ausgezeichnet haben.

De prestige en elegantie van Belgische blauwe hardsteen komen terug tot leven in deze innovatieve Refin tegelcollectie, uitdrukking van de meest hoogstaande productietechnologieën gecombineerd met de ervaring en kennis die al jarenlang het onderscheidend teken zijn van gres porcellanato van Refin.

El valor y la elegancia de la Pierre Bleue de Bélgica reviven en las cerámicas Refin en una colección de contenido altamente innovador, expresión de las más avanzadas tecnologías de producción combinadas con la experiencia y la cultura cerámica que desde siempre caracterizan el gres porcelánico Refin.

✂ 9 mm

60x60/24"x24" R  
30x60/12"x24" R

✂ 9,5 mm

45x45/18"x18"

✂ 20 mm OUT2.0

40x120/16"x48" R  
90x90/36"x36" R  
60x90/24"x36" R  
45x90/18"x36" R  
60x60/24"x24" R

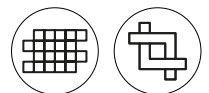



V2  
Slight

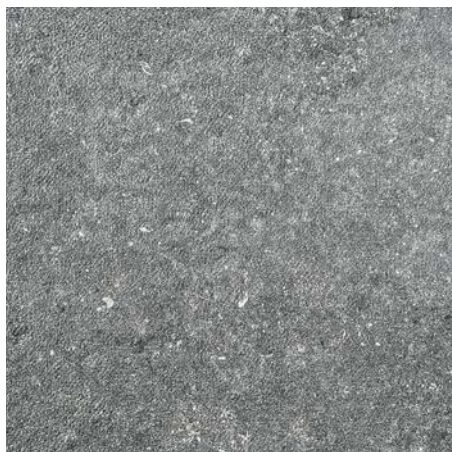
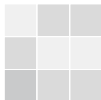

**Design** 60x60/24"x24" R  
30x60/12"x24" R  
45x45/18"x18"  
60x60/24"x24" R OUT2.0

**I602**  
NF16  
L991  
LG92

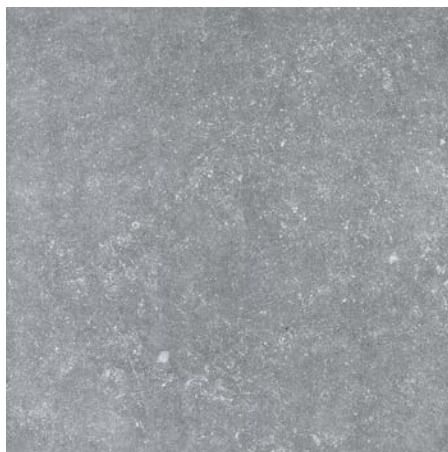

**Vintage Plain** 60x60/24"x24" R  
30x60/12"x24" R  
45x45/18"x18"  
40x120/16"x48" R OUT2.0  
90x90/36"x36" R OUT2.0  
60x90/24"x36" R OUT2.0  
45x90/18"x36" R OUT2.0  
60x60/24"x24" R OUT2.0

**L169**  
NF17  
L988  
MI49  
MT62  
NH59  
LP23  
LC63



**Vintage Charbon** 60x60/24"x24" R  
45x45/18"x18"  
45x90/18"x36" R OUT2.0  
60x60/24"x24" R OUT2.0

**L673**  
L989  
LP24  
LH28

Mosaici/Mosaics/Mosaïques/  
Mosaiken/Mozaïeken/Mosaicos



V2  
Slight

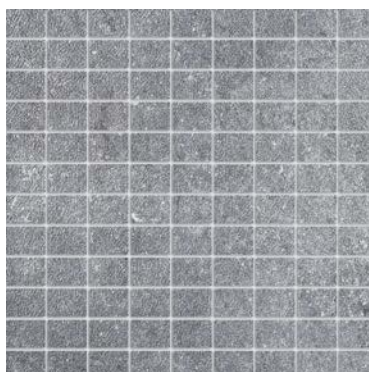
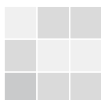

**Design Mosaico** 30x30/12"x12"

**L156**

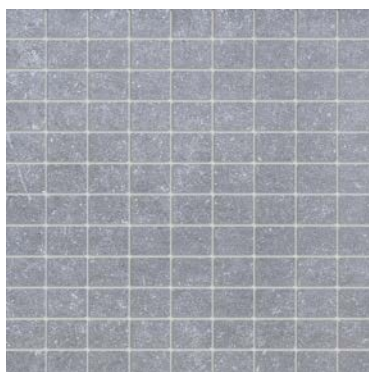

**Vintage Plain Mosaico** 30x30/12"x12"

**L157**

Pezzi speciali/Trim tiles/Pieces speciales/Formteile/Speciale delen/Piezas especiales



Battiscopa

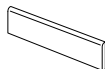

10x60/4"x24" R

Design  
Vintage Plain

I652  
LZ98

Imballi/Packing/Emballage/Verpackungseinheiten/Verpakking/Embalajes

	pcs x box	m <sup>2</sup> / m x box	kg x box	box x pallet	m <sup>2</sup> x pallet	kg x pallet
60x60/24"x24"	3	1,0800	21,35	40	43,20	854,00
30x60/12"x24"	7	1,2600	25,00	40	50,40	1000,00
45x45/18"x18"	5	1,0125	20,60	33	33,41	679,80
40x120/16"x48" OUT2.0	2	0,9600	41,50	24	23,04	996,00
90x90/36"x36" OUT2.0	1	0,8100	37,60	18	14,58	676,80
60x90/24"x36" OUT2.0	2	1,0800	48,50	18	19,44	873,00
45x90/18"x36" OUT2.0	2	0,8100	37,00	27	21,87	999,00
60x60/24"x24" OUT2.0	2	0,7200	32,40	30	21,60	972,00
30x30/12"x12" Mosaico	11	0,9900	19,00	18	17,82	342,00
10x60/4"x24" Battiscopa	10	6,0000	11,50	60	360,00	690,00

Caratteristiche/Features/Caracteristiques/Eigenschaften/Eigenschappen/Características



UNI EN ISO 10545/14

Classe 5 / Class 5



DIN 51130

R9 Vintage Charbon  
R10 Design, Vintage Plain  
R11 OUT2.0



DIN 51097

A+B Vintage Plain  
A+B+C Design



B.C.R.A. Rep. CEC/81

Asciutto > 0,40 /  
Bagnato > 0,40



ANSI A137.1-2012 (BOT3000)

> 0,42 Wet



## Urban renaissance

Bricklane, celebre strada nell'East London, da quartiere storicamente popolare e multi-etnico è diventata negli ultimi anni una delle zone più dinamiche e creative della città, dove le ex fornaci di mattoni ("brick" appunto) si sono trasformate in poli culturali e d'intrattenimento. Proprio questi edifici di archeologia industriale sono lo spunto per superfici materiche innovative che sembrano già usurate dal tempo: il particolare effetto invecchiato della collezione e i decori disponibili sono in grado di abbinarsi sia agli interni antichi sia ad ambienti dallo stile più metropolitano, grazie anche ai diversi formati pensati per rispondere a tutte le esigenze progettuali.

Bricklane, a famous street in a traditionally popular, multi-ethnic district in the East End of London, has in the last few years become one of the most dynamic, creative spots in the city, where the former brickworks have become meccas for culture and entertainment. It is these very examples of industrial archaeology that have provided the inspiration for innovative material surfaces that already appear worn down by the passage of time: the distinctive aged effect that characterises the collection, and the decorations that complement it, are able to slot seamlessly and attractively into both traditional and more modern metropolitan settings, also thanks to the variety of sizes designed to meet a wide range of project requirements.

Bricklane, célèbre rue à l'est de Londres, s'est transformée, lors de ces dernières années, de quartier historiquement populaire et multiethnique en l'une des zones les plus dynamiques et créatives de la ville, où les anciennes briqueteries (les "brick" justement) se sont transformées en des pôles de culture et de divertissement. Ces édifices d'archéologie industrielle constituent précisément la source d'inspiration pour des surfaces matiéristes novatrices qui semblent déjà usées par le temps. L'effet particulier vieilli de la collection et les décorations proposées sont en mesure de s'associer aussi bien aux intérieurs antiques qu'aux environnements au style plus métropolitain, grâce notamment aux différents formats pensés pour répondre à toutes les exigences en matière de conception.

Bricklane, die berühmte Straße in East London, ist in den letzten Jahren von einem traditionell multikulturellen Arbeiterviertel zu einer der dynamischsten und kreativsten Gegenden der Stadt geworden, in der die früheren Ziegeleien (Ziegel = brick) sich in Kultur- und Unterhaltungszentren verwandelt haben. Genau diese Gebäude der Industriearchäologie dienen als Anregung für materische Oberflächen, die bereits durch die Zeit verschlissen scheinen: Die besondere gealterte Optik der Kollektion und die angebotenen Dekore sind fähig, sich sowohl an alte Innenräume, als auch an Umgebungen mit einem großstädtischeren Stil anzupassen, was auch den verschiedenen Formaten zu verdanken ist, die allen Anforderungen gerecht werden sollen.

Bricklane, een bekende straat in East London, groeide de laatste jaren uit van multi-etnische volkse buurt tot één van de meest dynamische en creatieve stadsdelen, waar de voormalige steenfabrieken ("brick") werden omgevormd tot bruisende plekken vol cultuur en entertainment. Deze industriële archeologische locaties zijn verantwoordelijk voor het tot stand komen van innovatieve oppervlakken die gedragen door de tijd een vintage karakter verkrijgen: de verouderde uitstraling van de collectie en de voorgestelde decoraties integreren zich perfect in zowel een antiek als eigentijds urban-stijl interieur, mede dankzij de verscheidenheid aan formaten die speciaal ontworpen werden om te voldoen aan alle ontwerpeisen.

Brick Lane, célebre calle de East London, el histórico barrio popular y multiétnico que se ha convertido en los últimos años en una de las zonas más dinámicas y creativas de la ciudad, ha visto sus antiguos hornos de ladrillos (los "brick") transformarse en polos culturales y de ocio. Dichos edificios de arqueología industrial son la inspiración de superficies matéricas innovadoras que ya parecen desgastadas por el tiempo. El detalle envejecido de la colección y las decoraciones que se proponen pueden combinarse tanto con interiores de estilo antiguo como con ambientes más urbanos, gracias también a los diferentes formatos concebidos para satisfacer todas las exigencias de proyectos.

✂ 9 mm

60x60/24"x24"R  
30x60/12"x24"R  
30x30/12"x12"

✂ 9,5 mm

45x45/18"x18"



Fondi/Plain Tiles/Fonds/  
Grundfliesen/Fondsen/Fondos

V2  
Slight



**Light**      60x60/24"x24" R      LQ31  
                  30x60/12"x24" R      NF23  
                  45x45/18"x18"      LQ58  
                  30x30/12"x12"      NG73



**Grey**      60x60/24"x24" R      LQ32  
                  30x60/12"x24" R      NF21  
                  45x45/18"x18"      LQ59  
                  30x30/12"x12"      NG72



**Beige**      60x60/24"x24" R      LQ30  
                  30x60/12"x24" R      NF19  
                  45x45/18"x18"      LQ57  
                  30x30/12"x12"      NG71



**Trend**      60x60/24"x24" R      LQ33  
                  30x60/12"x24" R      NF26  
                  45x45/18"x18"      LQ56  
                  30x30/12"x12"      NG74



**Umber**      60x60/24"x24" R      LQ34  
                  30x60/12"x24" R      NF28  
                  45x45/18"x18"      LQ60  
                  30x30/12"x12"      NG75

Trend 60x60/24"x24" R Pick Out 30x30/12"x12" R Beige 30x60/12"x24" R

Bricklane  
52/53





32 soggetti diversi  
formato 30x30  
(miscelazione casuale)/  
32 assorted motifs  
30x30 size (random mix)/  
32 sujets differents  
format 30x30  
(melange aleatoire)/  
32 verschiedene  
Motive Format 30x30  
(Zufallsmischung)/  
32 verschillende  
ontwerpen in 30x30  
(willekeurig gemengd)/  
32 motivos diferentes  
formato 30x30  
(mezcla casual)



Pick Out 30x30/12"x12" R  
30x30/12"x12"

NG76  
NG77

Pezzi speciali/Trim tiles/Pieces speciales/Formteile/Speciale delen/Piezas especiales



Battiscopa

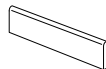

7x60/2<sup>7/8</sup>"x24" R

Beige	LQ38
Grey	LQ40
Light	LQ39
Trend	LQ41
Umber	LQ42

Imballi/Packing/Emballage/Verpackungseinheiten/Verpakking/Embalajes

	pcs x box	m <sup>2</sup> / m x box	kg x box	box x pallet	m <sup>2</sup> x pallet	kg x pallet
60x60/24"x24"	3	1,0800	21,35	40	43,20	854,00
30x60/12"x24"	7	1,2600	25,00	40	50,40	1000,00
45x45/18"x18"	5	1,0125	20,60	33	33,41	679,80
30x30/12"x12"	12	1,0800	20,50	48	51,84	984,00
30x30/12"x12" Deco	12	1,0800	20,50	48	51,84	984,00
7x60/2 <sup>7/8</sup> "x24" Battiscopa	10	6,0000	9,00	70	420,00	630,00

Caratteristiche/Features/Caracteristiques/Eigenschaften/Eigenshappen/Características



UNI EN ISO 10545/14

Classe 5 / Class 5



DIN 51130

R9



B.C.R.A. Rep. CEC/81

Asciutto > 0,40 / Bagnato > 0,40



ANSI A137.1-2012 (BOT3000)

> 0,42 Wet



Naturel 37,5x150/15"x60" R



## Everyday masterpiece

Retaggio di fasti rinascimentali, Chevron ricorda i pavimenti in legno posati a spina francese o punto ungherese – *point d'hongrie* o appunto *chevron* – creando intarsi lignei di importante ed elegante presenza. Ricorrente anche nelle sale della Reggia di Versailles a Parigi, questa straordinaria tecnica arricchisce gli ambienti, diventando essa stessa opera di alto artigianato, ed è quindi adatta per contesti residenziali di eccellenza o per spazi pubblici, commerciali o di rappresentanza come musei, gallerie, boutique di haute couture, atelier. L'unico formato 37,5x150 consente a due piastrelle affiancate di disegnare la spina completa. Chevron è disponibile in un legno caldo, uno più freddo e uno sbiancato quasi con effetto bianco/nero.

A legacy of the great Renaissance glory, the Chevron collection is reminiscent of the old wood parquet flooring, with slats arranged in imposingly elegant patterns, referred to as Hungarian herringbone or *point d'hongrie* and the *chevron*. An extraordinary technique that was also frequently used in the great halls of Versailles adds a touch of prestige to any room, in which it becomes a work of art in its own right. It is thus suited to more elegant areas around the home, to communal and commercial areas, and to other more refined areas open to the public such as museums, galleries, fashion boutiques and showrooms. One size only (37,5x150) is available which means that only two tiles placed side by side are needed to create a full chevron layout. Chevron is available in different tones of wood: a warmer shade, a cooler shade and a whitened shade, almost with a black/white effect.

Héritage des fastes de la Renaissance, la collection Chevron rend hommage au parquet à bâtons rompus ou *point de Hongrie* – ou en chevrons, justement – en créant avec des lames effet bois d'élégants motifs particulièrement séduisants. Souvent présente dans les appartements de Versailles, la pose en chevrons est une technique extraordinaire par sa capacité d'enrichir les pièces dont le sol se transforme en chef-d'œuvre de haut artisanat. De ce fait, les chevrons sont indiqués dans les espaces résidentiels de prestige ou dans les espaces publics, commerciaux ou de représentation tels que les musées, les galeries, les boutiques de haute couture et les ateliers. Son format unique, de 37,5x150, permet à deux carreaux juxtaposés de former un chevron complet. La collection Chevron est disponible en une tonalité chaleureuse de bois, dans un ton plus froid, et avec un aspect blanchi, pour un effet presque noir et blanc.

Chevron erinnert an Französisches Fischgrät oder Parkettboden ungarischer Art (*point d'hongrie*) – ein Vermächtnis der Pracht der Renaissancezeit, das Intarsien von eleganter Präsenz entstehen lässt. Auch in den Räumlichkeiten des Schlosses von Versailles in Paris finden wir dieses Parkett. Es handelt sich um eine außergewöhnliche Technik, die sich durch hochwertige Verarbeitung auszeichnet und dem Raum eine besondere Atmosphäre verleiht. Chevron eignet sich daher für anspruchsvolle Wohnräume oder öffentliche Räume, Gewerberäume oder repräsentative Bereiche wie Museen, Galerien, exklusive Boutiquen für Haute-Couture und Ateliers. Chevron ist nur in dem Format 37,5x150 erhältlich, das es ermöglicht zwei Fliesen so aneinanderzufügen, dass ein vollständiges Muster entsteht. Erhältlich ist die Fliese in einem warmen Holzton in einer etwas kühleren und einer fast weißen gebleichten Version, sodass annähernd ein Schwarz-Weiß-Effekt erzielt werden kann.

Erfgoed van glorie uit de Renaissance. Chevron doet denken aan houten vloeren met Frans graafmotief of Hongaarse punt – *point d'hongrie* of gewoonweg *chevron* genoemd. Deze tegel is perfect voor het creëren van opvallende en elegante houtkerfmotieven. Deze buitengewone techniek, die beslist de omgeving verrijkt, werd vaak gebruikt in de zalen van het paleis van Versailles, te Parijs. Dit ambachtelijke meesterwerk is dus zeer geschikt om hoogstaande residentiële contexten of openbare, commerciële of representatieve ruimten in te kleden, zoals musea, galerijen, zoals musea, galerijen, haute couture boetieks en ateliers. Door plaatsing van twee tegels naast elkaar tekent deze lijn met één enkel formaat van 37,5x150 het volledige graatmotief af. Chevron is beschikbaar in een warme houttint, een koudere houttint en één gebleekte tint met een quasi wit/zwart effect.

Reliquia renacentista, Chevron nos recuerda los suelos de madera en espina francés o punta de Hungría (*point d'hongrie* o, precisamente, *chevron*) al crear extraordinarias y elegantes taraceas. También empleada en las habitaciones del Palacio de Versailles en París, esta espectacular técnica adorna los espacios, y al ser por sí misma una obra artesanal de elevada destreza, es apta para refinados ambientes residenciales o para espacios públicos, comerciales o de exhibición como museos, galerías, boutique de alta costura y talleres. El único formato 37,5x150 permite que los dos azulejos contiguos reproduzcan totalmente el patrón espina. Chevron está disponible en una cálida madera, en otra más fría o en una tercera descolorida casi con efecto blanco/negro.

± 9 mm

37,5x150/15"x60" R

Gres porcellanato  
Porcelain stoneware  
Grès cérame fin vitrifié  
Feinsteinzeug  
Porseleingres  
Gres porcelánico

V4  
Substantial



Gris 37,5x150/15"x60" R LJ42



Naturel 37,5x150/15"x60" R LJ44



Huilé 37,5x150/15"x60" R LJ43

Blanchi 37,5x150/15"x60" R



V2  
Slight

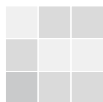

**Blanchi** 37,5x150/15"x60" R MB77



**Vielli** 37,5x150/15"x60" R MB76



**Charme** 37,5x150/15"x60" R MB78



**Foncé** 37,5x150/15"x60" R MB79

Per le indicazioni di posa vedere pagina 60.  
For laying indications, see page 60.  
Pour les indications de pose, voir à la page 60.  
Für die Verlegehinweise siehe Seite 60.  
Voor aanwijzingen over de plaatsing: zie pagina 60.  
Para las instrucciones de colocación, ver la página 60.

Naturel 37,5x150/15"x60" R

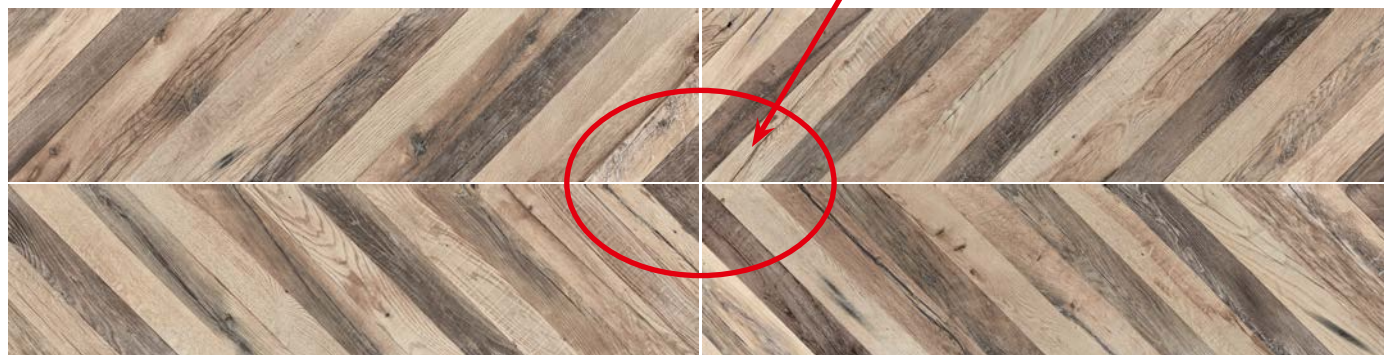

YES

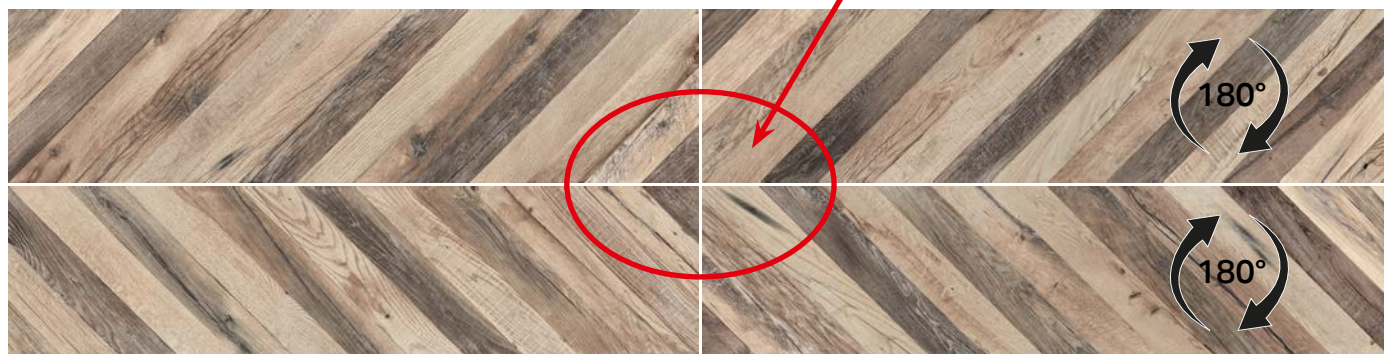

NO

Per ottimizzare il risultato estetico si consiglia di rispettare il modello di posa qui riportato.  
For best aesthetic results, we recommend following the laying model shown above.  
Pour optimiser le résultat esthétique, il est conseillé de respecter le calepinage suggéré.  
Um das ästhetische Ergebnis zu optimieren, empfiehlt es sich, das hier dargestellte Verlegemuster einzuhalten.  
Para optimizar el resultado estético, se recomienda respetar el modelo de solado aquí indicado.  
Voor een optimaal esthetisch resultaat raden wij aan het hier vermelde plaatsingschema te respecteren.

La non perfetta continuità di linee e/o motivi grafici tra una piastrella e quella adiacente è naturale conseguenza del processo produttivo. Tale caratteristica pertanto non costituisce un vizio del prodotto e non potrà dar luogo ad alcuna contestazione; in particolar modo, nessun intervento di sostituzione potrà essere richiesto, nel caso di materiale già posato.

Any breaks in the continuity of lines and/or patterns between a tile and the one next to it are a natural consequence of the manufacturing process, and may not be considered a defect or cause for complaint. Please note that no requests will be accepted for replacement of any material already laid.

L'imparfaite continuité de lignes et/ou de motifs graphiques d'un carreau à l'autre est une conséquence naturelle du procédé de production. Cette caractéristique ne constitue donc pas un vice de fabrication du produit et ne pourra pas être contestée ni ne pourra faire l'objet d'une demande de substitution après la pose.

Die Unvollkommenheit der Kontinuität der Linien und/oder grafischen Motive zwischen einer Fliese und der angrenzenden ist eine natürliche Folge des Produktionsprozesses. Dieses Merkmal stellt daher keinen Produktmangel dar und kann nicht beanstandet werden. Insbesondere kann im Fall, dass das Material bereits verlegt wurde, kein Ersatz gefordert werden.

Het is mogelijk dat de overgang van lijnen en/of patronen tussen een tegel en de volgende niet perfect is. Dit is een natuurlijk gevolg van het productieproces. Deze eigenschap kan niet worden beschouwd als een defect van het product, en kan niet gelden als een aanleiding voor een geschil. Indien de tegels al zijn gelegd, zullen we niet ingaan op verzoeken om deze te vervangen.

La continuidad imperfecta de líneas y/o motivos gráficos entre las baldosas es una consecuencia natural del proceso de producción. Esta característica no constituye un defecto en el producto y no dará lugar a ninguna reclamación; en particular, no se podrá solicitar ninguna sustitución si el material ya ha sido colocado.

Imballi/Packing/Emballage/Verpackungseinheiten/Verpakking/Embalajes

	pcs x box	m <sup>2</sup> / m x box	kg x Box	box x pallet	m <sup>2</sup> / m x pallet	kg x pallet
37,5x150/15"x60"	2	1,1250	24,50	30	33,75	735,00

Foncé 37,5x150/15"x60" R



Caratteristiche/Features/Caracteristiques/Eigenschaften/Eigenschappen/Características



UNI EN ISO 10545/14

Classe 5 / Class 5



DIN 51130

R10



B.C.R.A. Rep. CEC/81

Asciutto > 0,40 / Bagnato > 0,40



ANSI A137.1-2012 (BOT3000)

> 0,42 Wet

Mud 120x120/48"x48" Soft R — Coral 120x278/48"x110" R



## Melting colours

Superfici che trasmettono sensazioni di morbidezza e profondità: Creos reinterpreta l'aspetto più artigianale della resina spatolata attraverso una texture delicatamente mossa e irregolare, caratterizzata da zone leggermente lucide ed altre più opache, tipiche del processo di asciugatura della resina. La palette cromatica è composta da cinque colori neutri, l'elegante bianco *Bride*, i due grigi freddi *Dorian* e *Shadow* e i due toni caldi *Cookie* e *Mud*, e due inedite proposte colorate, *Bluebay* e *Coral*, disponibili anche nel nuovo grande formato 120x278 e in grado di creare ambienti dalla spiccata potenza espressiva.

Surfaces that convey feelings of softness and depth: Creos reinterprets the most hand-crafted aspect of spatula-look resin thanks to a delicately shifting and irregular texture, distinguished by areas that are slightly polished and others that are more matt, typical of the resin drying process. The colour palette consists of five neutral colours, the stylish *Bride* white, two cold greys, *Dorian* and *Shadow* and two warm hues, *Cookie* and *Mud*, as well as two unprecedented coloured variants, *Bluebay* and *Coral*, which are also available in the new large 120x278 size and designed to create settings with a bold expressive force.

Des surfaces qui transmettent des sensations de douceur et profondeur: Creos revisite l'aspect le plus artisanal de la résine effet spatule à travers une texture délicatement ondulée et irrégulière, caractérisée par des zones légèrement brillantes et d'autres plus mates, typiques du processus de séchage de la résine. La palette de couleurs est composée de cinq coloris neutres, l'élégant blanc *Bride*, les deux gris froids *Dorian* et *Shadow* et les deux tons chauds *Cookie* et *Mud*, ainsi que deux propositions colorées inédites, *Bluebay* et *Coral*, également disponibles dans le nouveau grand format 120x278, en mesure de créer des environnements

Oberflächen, die Weichheit und Tiefe vermitteln: Creos interpretiert den handwerklicheren Aspekt des Spachtelharzes durch eine fein gewellte und unregelmäßige Textur neu, die sich durch leicht glänzende und undurchsichtige Bereiche auszeichnet, die für den Trocknungsprozess des Harzes typisch sind. Die Farbpalette besteht aus fünf neutralen Farben, dem eleganten *Bride* Weiß, den beiden kalten Grautönen *Dorian* und *Shadow* sowie zwei neuen farbigen Vorschlägen *Bluebay* und *Coral*, die auch im neuen Großformat 120x278 erhältlich sind und Umgebungen mit starker Ausdruckskraft schaffen, charakterisiert durch ihre puiissance expressive.

Oppervlakken die het gevoel van zachtheid en diepte uitstralen: Creos herinterpreteert het ambachtelijkere aspect van gespatelde hars door een licht bewegende, onregelmatige textuur, gekenmerkt door afwisselend glanzende en mattere zones, die typisch zijn voor het droogproces van hars. Het kleurenpalet bestaat uit vijf neutrale kleuren: het elegante wit *Bride*, de twee koude grijs tinten *Dorian* en *Shadow* en de twee warme tinten *Cookie* en *Mud*, en twee geheel nieuwe kleuren *Bluebay* en *Coral*, ook leverbaar in het nieuwe grote formaat 120x278 en in staat om ruimten te creëren met een sterk expressief vermogen.

Superficies que transmiten sensaciones de suavidad y profundidad, Creos reinterpreta el aspecto más artesanal de la resina espatulada por medio de una textura delicadamente ondulada e irregular, caracterizada por la presencia de zonas con un ligero brillo y otras más opacas, típicas del proceso de secado de la resina. La paleta cromática consta de cinco colores neutros: el elegante blanco *Bride*, los dos grises fríos *Dorian* y *Shadow*, los dos tonos cálidos *Cookie* y *Mud*, y las dos originales propuestas de color, *Bluebay* y *Coral*, que están disponibles también en el nuevo formato grande de 120x278 y permiten crear ambientes con gran capacidad expresiva.

6 mm

120x278/48"x110" R

9 mm

120x120/48"x48" Soft R  
60x120/24"x48" Soft R  
75x75/30"x30" Soft R  
60x60/24"x24" R  
60x60/24"x24" Soft R  
30x60/12"x24" R  
30x60/12"x24" Soft R

9,5 mm

45x45/18"x18" Soft

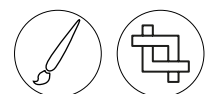

Gres porcellanato  
Porcelain stoneware  
Grès cérame fin vitrifié  
Feinsteinzeug  
Porseleingres  
Gres porcelánico



V2  
Slight

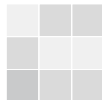

**Bride**

120x278/48"x110" R	<b>MK86</b>
120x120/48"x48" Soft R	<b>MK20</b>
60x120/24"x48" Soft R	<b>NA62</b>
75x75/30"x30" Soft R	<b>NU51</b>
60x60/24"x24" R	<b>NA50</b>
60x60/24"x24" Soft R	<b>NA51</b>
30x60/12"x24" R	<b>NC99</b>
30x60/12"x24" Soft R	<b>ND00</b>
45x45/18"x18" Soft	<b>ND67</b>



**Dorian**

120x278/48"x110" R	<b>MK87</b>
120x120/48"x48" Soft R	<b>MK24</b>
60x120/24"x48" Soft R	<b>NA66</b>
75x75/30"x30" Soft R	<b>NU53</b>
60x60/24"x24" R	<b>NA54</b>
60x60/24"x24" Soft R	<b>NA55</b>
30x60/12"x24" R	<b>ND03</b>
30x60/12"x24" Soft R	<b>ND04</b>
45x45/18"x18" Soft	<b>ND69</b>



**Shadow**

120x120/48"x48" Soft R	<b>MK28</b>
60x120/24"x48" Soft R	<b>NA70</b>
60x60/24"x24" R	<b>NA58</b>
60x60/24"x24" Soft R	<b>NA59</b>
30x60/12"x24" R	<b>ND07</b>
30x60/12"x24" Soft R	<b>ND08</b>
45x45/18"x18" Soft	<b>ND71</b>



**Cookie**

120x120/48"x48" Soft R	<b>MK22</b>
60x120/24"x48" Soft R	<b>NA64</b>
75x75/30"x30" Soft R	<b>NU52</b>
60x60/24"x24" R	<b>NA52</b>
60x60/24"x24" Soft R	<b>NA53</b>
30x60/12"x24" R	<b>ND01</b>
30x60/12"x24" Soft R	<b>ND02</b>
45x45/18"x18" Soft	<b>ND68</b>



**Mud**

120x120/48"x48" Soft R	<b>MK26</b>
60x120/24"x48" Soft R	<b>NA68</b>
75x75/30"x30" Soft R	<b>NU54</b>
60x60/24"x24" R	<b>NA56</b>
60x60/24"x24" Soft R	<b>NA57</b>
30x60/12"x24" R	<b>ND05</b>
30x60/12"x24" Soft R	<b>ND06</b>
45x45/18"x18" Soft	<b>ND70</b>



**Bluebay** 120x278/48"x110" R NB02  
120x120/48"x48" Soft R ND56  
60x120/24"x48" Soft R ND53  
60x60/24"x24" Soft R ND59  
30x60/12"x24" Soft R ND62



**Coral** 120x278/48"x110" R NB03  
120x120/48"x48" Soft R ND57  
60x120/24"x48" Soft R ND54  
60x60/24"x24" Soft R ND60  
30x60/12"x24" Soft R ND63

**Shadow** 120x120/48"x48" Soft R



## Pezzi speciali/Trim tiles/Pieces speciales/Formteile/Speciale delen/Piezas especiales

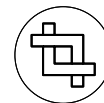

### Battiscopa



#### 7x75/2<sup>7/8</sup>"x30" R

Bride	<b>NU28</b>
Cookie	<b>NU29</b>
Dorian	<b>NU30</b>
Mud	<b>NU31</b>

#### 7x60/2<sup>7/8</sup>"x24" R

Bride	<b>MK33</b>
Cookie	<b>MK34</b>
Dorian	<b>MK35</b>
Mud	<b>MK36</b>
Shadow	<b>MK37</b>
Bluebay	<b>NH61</b>
Coral	<b>NH62</b>

## Imballi/Packing/Emballage/Verpackungseinheiten/Verpakking/Embalajes

	pcs x box	m <sup>2</sup> / m x box	kg x box	box x pallet	m <sup>2</sup> x pallet	kg x pallet
120x278/48"x110"	1	3,3360	49,56	18	60,05	892,08
120x120/48"x48"	2	2,8800	58,00	20	57,60	1160,00
60x120/24"x48"	2	1,4400	31,50	35	50,40	1102,50
75x75/30"x30"	2	1,1250	24,00	42	47,25	1008,00
60x60/24"x24"	3	1,0800	21,35	40	43,20	854,00
30x60/12"x24"	7	1,2600	25,00	40	50,40	1000,00
45x45/18"x18"	5	1,0125	20,60	33	33,41	679,80
7x75/2 <sup>7/8</sup> "x30" Battiscopa	10	7,5000	11,00	54	405,00	594,00
7x60/2 <sup>7/8</sup> "x24" Battiscopa	10	6,0000	9,00	70	420,00	630,00

The MATT and SOFT finishes are recommended for interior floors, walls, and exterior walls in both residential and commercial applications. Creos is not recommended for exterior horizontal surfaces or exterior paving, and they are not recommended for ramps application. The SOFT finish is not recommended for interior floors in entrance areas if joined to outdoor in commercial applications.

## SOFT Caratteristiche/Features/Caracteristiques/Eigenschaften/Eigenshappen/Características



UNI EN ISO 10545/14

Classe 5 / Class 5



B.C.R.A. Rep. CEC/81

Asciutto > 0,40 / Bagnato > 0,40



ANSI A137.1-2012 (BOT3000)

> 0,42 Wet

## MATT Caratteristiche/Features/Caracteristiques/Eigenschaften/Eigenshappen/Características



UNI EN ISO 10545/14

Classe 5 / Class 5



DIN 51130

R10



B.C.R.A. Rep. CEC/81

Asciutto > 0,40 / Bagnato > 0,40



ANSI A137.1-2012 (BOT3000)

> 0,42 Wet



Polvere 01 60x60/24"x24" R (NCS S 2002 - B)  
Polvere 02 60x60/24"x24" R (NCS S 4502 - B)



## Colour for innovation

Interpretare lo spazio secondo un'uniformità visiva, attorno a una grammatica comune che è quella del colore: queste le potenzialità innovative espresse dalla gamma Cromie, frutto della ricerca sulla componente cromatica intesa come variabile essenziale nello sviluppo del pensiero progettuale. Le 14 tonalità della collezione sono definite attraverso la Notazione NCS - Natural Color System® che ne identifica la componente cromatica e rende possibile la definizione di precisi accostamenti con gli altri elementi che concorrono alla progettazione dello spazio, quali pitture murali, complementi, tessuti d'arredo, rafforzando così l'uso strategico della ceramica in ambito progettuale.

Interpreting space in line with a smooth visual effect, shaped around the common element of colour: this is the innovative potential offered by Cromie, the result of research into colour as an essential variable in the development of project thinking. The 14 shades of the collection are defined using the Natural Color System® - NCS notations which identify the chromatic component and makes it possible to establish suitable combinations between ceramics and the other elements that contribute to the design of a setting, such as wall paintings, furnishing accessories and fabrics, thus reinforcing the strategic use of ceramics in the design field.

Interpréter l'espace selon une uniformité visuelle, autour d'une morphologie commune qui est celle de la couleur. Tel est le potentiel d'innovation exprimé par Cromie, une collection issue de la recherche sur la composante chromatique vue comme variable essentielle dans le développement de la pensée conceptuelle. Les 14 tonalités de la collection sont définies en utilisant la Notation NCS - Natural Color System® qui en identifie la composante chromatique et permet la définition de rapprochements précis avec les autres éléments qui contribuent à la conception de l'espace, telles les peintures murales, les compléments et les tissus d'ameublement, en renforçant ainsi l'utilisation stratégique de la céramique dans le secteur de la conception.

Den Raum nach einer visuellen Gleichmäßigkeit mit einer gemeinsamen Grammatik, nämlich der der Farbe, interpretieren: Darin besteht das innovative Potential, das Cromie zum Ausdruck bringt, ein Ergebnis der Forschung bezüglich der Farbkomponente im Sinne einer grundlegenden Variabel in der Ausarbeitung der Projektideen. Die 14 Farbtöne der Kollektion sind durch die Notation NCS - Natural Color System® definiert, die jeweils ihre Farbkomponente identifiziert und die Definition präziser Kombinationen mit den übrigen, in die Raumplanung einbezogenen Elementen ermöglicht. Dazu gehören beispielsweise Wandmalereien, Einrichtungselemente, Dekorstoffe. Damit wird der strategische Einsatz der Keramik in der Planung verstärkt.

Het interpreteren van de ruimte volgens een visuele uniformiteit met een gemeenschappelijke Chromatische morfologie: dit zijn de innovatieve perspectieven uitgedrukt door Cromie, als antwoord op het onderzoek naar het chromatische aandeel als essentiële variabele in de projectontwikkeling. De 14 tinten van de collectie zijn omschreven door de kleurnormering NCS - Natural Color System®, die de chromatische component ervan identificeert en het mogelijk maakt om precieze combinaties met de andere elementen te bepalen die bijdragen aan het ontwerp van de ruimte, zoals muurschilderingen, artikelen voor de inrichting, woonstoffen, waardoor het strategisch gebruik van de tegels bij het ontwerp wordt versterkt.

Interpretar el espacio según una uniformidad visual, entorno a la gramática común del color. Son las novedosas potencialidades que Cromie expresa, el fruto de la exploración de la componente cromática cual variable esencial del desarrollo de una idea proyectual. Las 14 tonalidades de la colección se definen a través de la Notación NCS - Natural Color System® que identifica el componente cromático y permite definir combinaciones precisas con los demás elementos que contribuyen al diseño del espacio, como pinturas murales, complementos, tejidos de decoración, reforzando así el uso estratégico de la cerámica en el sector del diseño.

✂ 9 mm

60x60/24"x24" R  
30x60/12"x24" R



Gres porcellanato  
Porcelain stoneware  
Grès cérame fin vitrifié  
Feinsteinzeug  
Porseleingres  
Gres porcelánico



NCS - Natural Colour System®  
property of and used on licence from  
NCS Colour AB, Stockholm 2020.  
The colours might not exactly match  
original NCS colour samples.

Fondi/Plain Tiles/Fonds/  
Grundfliesen/Fondsen/Fondos



**Polvere** 01    **60x60/24"x24" R**    **L862**  
**30x60/12"x24" R**    **NF69**



**Polvere** 02    **60x60/24"x24" R**    **L863**  
**30x60/12"x24" R**    **NF70**



**Polvere** 04    **60x60/24"x24" R**    **L865**  
**30x60/12"x24" R**    **NF72**



**Polvere** 05    **60x60/24"x24" R**    **L866**  
**30x60/12"x24" R**    **NF73**



**Polvere** 07    **60x60/24"x24" R**    **L868**  
**30x60/12"x24" R**    **NF75**



**Polvere** 09    **60x60/24"x24" R**    **L870**  
**30x60/12"x24" R**    **NF77**



**Fango**      **60x60/24"x24" R**      **L880**  
**01**      **30x60/12"x24" R**      **NF29**



**Fango**      **60x60/24"x24" R**      **L884**  
**05**      **30x60/12"x24" R**      **NF33**



**Fango**      **60x60/24"x24" R**      **L888**  
**09**      **30x60/12"x24" R**      **NF37**



**Terra**      **60x60/24"x24" R**      **MI32**  
**19**      **30x60/12"x24" R**      **NG43**



Tendenze 16 60x60/24"x24" R (NCS S 8502 - B)  
Tendenze 16 30x60/12"x24" R (NCS S 8502 - B)  
Tendenze 11 30x60/12"x24" R (NCS S 1002 - Y50R)



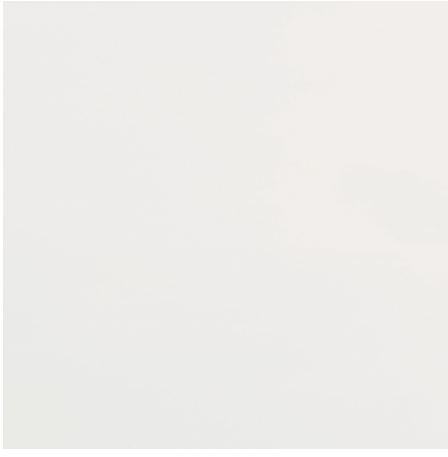

**Tendenze** 60x60/24"x24" R      **MI51**  
**11**      30x60/12"x24" R      **NG44**

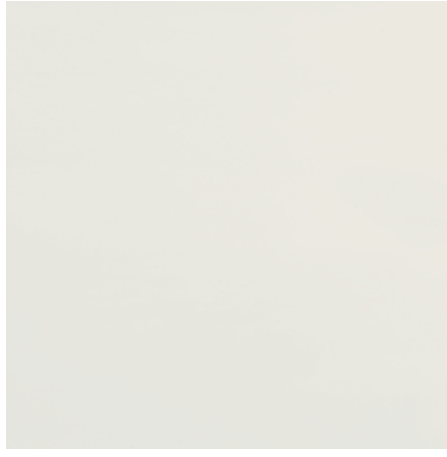

**Tendenze** 60x60/24"x24" R      **MI54**  
**14**      30x60/12"x24" R      **NG47**



**Tendenze** 60x60/24"x24" R      **MI55**  
**15**      30x60/12"x24" R      **NG48**



**Tendenze** 60x60/24"x24" R      **MI56**  
**16**      30x60/12"x24" R      **NG49**

Tendéze 14 60x60/24"x24" R (NCS S 1502 - Y50R)  
Tendéze 15 30x60/12"x24" (NCS S 5030 - Y70R)



Pezzi speciali/Trim tiles/Pieces speciales/Formteile/Speziale delen/Piezas especiales



Battiscopa	10x60/4"x24" R	10x60/4"x24" R		
	Fango 01	<b>L803</b>	Tendenze 11	<b>MH84</b>
	Fango 05	<b>L807</b>	Tendenze 14	<b>MH87</b>
	Fango 09	<b>L811</b>	Tendenze 15	<b>MH88</b>
	Polvere 01	<b>L794</b>	Tendenze 16	<b>MH89</b>
	Polvere 02	<b>L795</b>	Terra 19	<b>MH83</b>
	Polvere 04	<b>L797</b>		
	Polvere 05	<b>L798</b>		
	Polvere 07	<b>L800</b>		
	Polvere 09	<b>L802</b>		

Corrispondenze cromatiche / Colour matches / Correspondances chromatiques / Chromatische Entsprechungen / Chromatische correspondenties / Correspondencias cromáticas.

Cromie	NCS®	Cromie	NCS®
Polvere 01	NCS S 2002 - B	Fango 01	NCS S 2500 - Y
Polvere 02	NCS S 4502 - B	Fango 05	NCS S 4005 - Y20R
Polvere 04	NCS S 1500 - N	Fango 09	NCS S 6005 - Y20R
Polvere 05	NCS S 4000 - N	Tendenze 11	NCS S 1002 - Y50R
Polvere 07	NCS S 2002 - Y50R	Tendenze 14	NCS S 1502 - Y50R
Polvere 09	NCS S 4702 - R	Tendenze 15	NCS S 5030 - Y70R
Terra 19	NCS S 6005 - Y50R	Tendenze 16	NCS S 8502 - B

NCS - Natural Colour System® property of and used on licence from NCS Colour AB, Stockholm 2020.  
The colours might not exactly match original NCS colour samples.

Imballi/Packing/Emballage/Verpackungseinheiten/Verpakking/Embalajes

	pcs x box	m <sup>2</sup> / m x box	kg x box	box x pallet	m <sup>2</sup> x pallet	kg x pallet
60x60/24"x24"	3	1,0800	21,35	40	43,20	854,00
30x60/12"x24"	7	1,2600	25,00	40	50,40	1000,00
10x60/4"x24" Battiscopa	10	6,0000	11,50	60	360,00	690,00

Caratteristiche/Features/Caracteristiques/Eigenschaften/Eigenshappen/Características

UNI EN ISO 10545/14	DIN 51130	BS 7976-2:2002 (CEN/TS 16165, Annex C) Pendulum Friction Test	B.C.R.A. Rep. CEC/81	ANSI A137.1-2012 (BOT3000)
Classe 5 / Class 5	R9	≥ 36 Wet	Asciutto > 0,40 / Bagnato > 0,40	> 0,42 Wet

Day 25x150/10"x60" R



## Essential living

Atmosfera del centro Europa per Deck, un'essenza di rovere dal carattere rigoroso. La scelta della gamma cromatica e la definizione della texture superficiale leggermente ruvida fanno dei lunghi listoni, previsti in due formati (25x150 e 22,5x90), una proposta contemporanea di gusto lineare e con un mood naturale. Deck è declinata in sette tonalità prevalentemente calde che vanno dal chiaro – Dawn e Flare, di immediato rimando nord Europeo – fino ai più intensi colori Dusk, Blaze e Night, passando per i toni intermedi Day e Bright; anche la grafica asseconda questa gradualità diventando più marcata via via che il colore si scurisce, arricchita da diversi stadi di stonalizzazione tra le doghe per effetti più o meno omogenei.

Central European allure for Deck, an oak wood with a subtly classic appearance. The colour range available and the slightly rough surface texture make these long strip tiles, in two sizes (25x150 and 22,5x90), a simple, linear contemporary choice in keeping with a natural mood. Deck comes in seven mainly warm shades, ranging from the lighter Dawn and Flare, with a clearly North European air, through the intermediate shades of Day and Bright to the darker Dusk, Blaze and Night; the patterns also follow this gradual shift, becoming more marked as the colour darkens, enriched with a variety of degrees of shading for a more or less even effect.

Des atmosphères d'Europe centrale pour Deck, une essence de chêne rouvre empreinte de sobriété. Sa palette de couleurs et la texture légèrement rugueuse de sa surface font des grands listels prévus en deux formats (25x150 et 22,5x90), une proposition contemporaine de style linéaire et à l'esprit naturel. Deck se décline en sept tonalités à dominance chaude allant des plus claires – Dawn et Flare, évoquant le nord de l'Europe – aux plus intenses Dusk, Blaze et Night, en passant par les moyennes Day et Bright. Le graphisme contribue à cette progression en devenant de plus en plus marqué au fur et à mesure que la couleur s'assombrit, enrichie de différents degrés de stonalisation entre les lattes, pour des effets plus ou moins homogènes.

Mitteuropäische Atmosphären für Deck, eine Eichenholzart mit strengem Charakter. Die Wahl der Farbpalette und die Definition der etwas rauhen Oberflächentextur machen diese in zwei Formaten (25x150 und 22,5x90) geplanten langen Leisten zu einem zeitgemäßen Vorschlag mit linearem Stil und natürlicher Optik. Deck ist in sieben vorwiegend warmen Farbtönen ausgearbeitet, die von hellen Tönen – Dawn und Flare, die sofort an Nord-europa erinnern – über die Zwischentöne Day und Bright bis zu den intensiveren Farben Dusk, Blaze und Night reichen. Auch die Grafik kommt dieser Abstufung nach und wird – durch die verschiedenen Abtönungsstadien zwischen den Brettern bereichert – umso markanter, je dunkler die Farbe ist, wodurch mehr oder weniger einheitliche Effekte erzielt werden.

Centraal-Europese sferen voor Deck, de wintereik finish met streng karakter. De keuze van het kleurengamma en de enigszins ruwe oppervlaktetextuur, gecombineerd met twee lange tegelformaten (25x150 en 22,5x90), creëren lineaire hedendaagse ontwerpen met een natuurlijke mood. Deck fluctueert tussen zeven overwegend warme tinten, gaande van de lichte Noord-Europese Dawn en Flare, tot de meer intense Dusk, Blaze en Night, met daartussen de intermediaire nuances Day en Bright. Ook de grafische tekens volgen deze tendens en worden opvallender naarmate de kleur donkerder wordt. De diverse kleurschakeringen tussen de banen – al dan niet homogeen – verrijken nogmaals het patroon.

Las atmósferas de Europa Central envuelven Deck, una madera de roble de carácter determinado. Los listones largos, disponibles en dos formatos (25x150 y 22,5x90), son una propuesta contemporánea de elegancia lineal y un espíritu natural, gracias a la elección de la gama de colores y a la definición de la textura de la superficie ligeramente áspera. Deck está realizado en siete tonos preferentemente cálidos que abarcan desde el claro – Dawn y Flare, que evocan inmediatamente el norte de Europa – hasta los colores más intensos Dusk, Blaze y Night, pasando por los intermedios Day y Bright; también el grafismo favorece esta gradualidad siendo más marcado a medida que el color se oscurece, enriquecido por las diferentes etapas de destonalización entre los listones para crear efectos más o menos homogéneos.

9 mm

25x150/10"x60" R

22,5x90/9"x36" R



Gres porcellanato  
Porcelain stoneware  
Grès cérame fin vitrifié  
Feinsteinzeug  
Porseleingres  
Gres porcelánico





**Blaze**      25x150/10"x60" R      LX84  
                 22,5x90/9"x36" R      LZ22



**Night**      25x150/10"x60" R      LJ71  
                 22,5x90/9"x36" R      LJ72



**Dusk**      25x150/10"x60" R      LX88  
                 22,5x90/9"x36" R      LZ26



Pezzi speciali/Trim tiles/Pieces speciales/Formteile/Speciale delen/Piezas especiales



Battiscopa

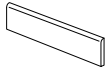

7x90/2<sup>7/8</sup>"x36" R

Blaze	LO41
Bright	LO42
Dawn	LO43
Day	LO44
Dusk	LO45
Flare	LO46
Night	LO40

Imballi/Packing/Emballage/Verpackungseinheiten/Verpakking/Embalajes

	pcs x box	m <sup>2</sup> / m x box	kg x box	box x pallet	m <sup>2</sup> x pallet	kg x pallet
25x150/10"x60"	3	1,1250	24,00	30	33,75	720,00
22,5x90/9"x36"	6	1,2150	25,80	36	43,74	928,80
7x90/2 <sup>7/8</sup> "x36" Battiscopa	6	5,4000	8,00	55	297,00	440,00

Caratteristiche/Features/Caracteristiques/Eigenschaften/Eigenshappen/Características



UNI EN ISO 10545/14

Classe 5 / Class 5



DIN 51130

R10



DIN 51097

A+B



B.C.R.A. Rep. CEC/81

Asciutto > 0,40 /  
Bagnato > 0,40



ANSI A137.1-2012 (BOT3000)

> 0,42 Wet



Raw Light 75x150/30"x60" R – Raw Mix 25x150/10"x60" R



## Multi-material

Collezione multimerica ispirata ai nuovi contesti urbani e alle tendenze architettoniche contemporanee: le due diverse tipologie di superfici, proposte in un'ampia gamma di formati e disponibili in numerose tonalità, favoriscono la massima libertà progettuale. La versione Oxyde evoca l'aspetto patinato dei metalli ossidati in un'alternanza di toni chiari e scuri, mentre Raw interpreta in chiave cromatica e strutturale l'effetto dei cementi e degli intonaci usurati. Queste caratteristiche sono esaltate soprattutto nel grande formato, che ne valorizza i tratti grafici permettendo di definire superfici senza soluzione di continuità.

Multi-material collection inspired by new urban contexts and contemporary architectural trends: two different surface finishes, in a wide range of sizes and a variety of colour shades, offering great design potential and freedom of choice. The Oxyde version is reminiscent of the patina of rusted metals, with alternating chiaroscuro hues, while Raw interprets the colours and textures of concrete and worn plaster. These characteristics are enhanced fully in the large sizes, which make the most of the graphic features and can be used to create large, continuous surfaces.

Une collection multimerica inspirée de nouveaux contextes urbains et des tendances architecturales contemporaines dont la vaste gamme de formats et la riche palette de couleurs des deux typologies de surface laissent la plus grande liberté conceptuelle. La variante Oxyde évoque l'aspect patiné des métaux oxydés, dans une alternance de tons clairs et foncés, tandis que Raw interprète, par ses couleurs et ses finitions structurelles, l'effet des ciments et des enduits usés. Des caractéristiques tout particulièrement rehaussées par le grand format qui non seulement valorise ses graphismes mais permet aussi de réaliser des surfaces ininterrompues.

Eine Kollektion, die mehrere Materialien verbindet, und sich am neuen urbanen Kontext und an zeitgenössischen Trends in der Architektur inspiriert: Die beiden verschiedenen Oberflächentypologien, die in einer reichen Auswahl an Formaten und in vielen Farbtönen erhältlich sind, ermöglichen maximale Gestaltungsfreiheit. Die Oberfläche Oxyde erinnert an das patinierte Aussehen oxidierter Metalle mit ihrem Wechsel zwischen hellen und dunklen Farbtönen, während Raw farblich und strukturell der Wirkung von Zement und abgeblättertem Putz nachempfunden ist. Diese Eigenschaften werden vor allem durch das große Format hervorgehoben, das die grafischen Ausdrucksmöglichkeiten verstärkt und erlaubt, eine durchgehende einheitliche Fläche zu schaffen.

Een multi material collectie met urban uitstraling, geïnspireerd op hedendaagse architectuurtrends: de twee verschillende soorten oppervlakken, beschikbaar in een breed gamma aan formaten en tinten, creëren een maximale vrijheid van ontwerp. De versie Oxyde doet denken aan het gesatineerd effect van geoxideerde metalen, met afwisselend lichte en donkere tinten. Raw is dan weer een chromatische en structurele interpretatie van afgeleefd cement en pleisterwerk. Deze karakteristieken worden extra benadrukt door de grote tegelformaten, die de grafische trekken valoriseren en continue oppervlakken creëren.

Colección multi-matérica inspirada en nuevos contextos urbanos y en las tendencias arquitectónicas contemporáneas: las dos tipologías diferentes de superficie, propuestas en una amplia gama de formatos y disponibles en numerosas tonalidades, ofrecen máxima libertad proyectual. La versión Oxyde evoca una pátina que alterna tonos claros y oscuros, mientras Raw interpreta en clave cromática y estructural el efecto de los yesos desgastados. Estas características se mejoran sobre todo en grandes formatos, dando valor a los trazos gráficos y permitiendo definir así superficies sin solución de continuidad.

✂ 9 mm

75x150/30"x60" R  
75x150/30"x60" Strutt. R  
25x150/10"x60" R  
25x150/10"x60" Strutt. R  
75x75/30"x30" R  
75x75/30"x30" Strutt. R  
60x60/24"x24" R  
30x60/12"x24" R

Gres porcellanato  
Porcelain stoneware  
Grès cérame fin vitrifié  
Feinsteinzeug  
Porseleingres  
Gres porcelánico

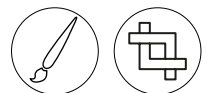

V3  
Moderate



<b>Oxyde</b>	<b>75x150/30"x60" R</b>	<b>LG88</b>
<b>White</b>	<b>25x150/10"x60" R</b>	<b>LG89</b>
	<b>75x75/30"x30" R</b>	<b>LG93</b>
	<b>60x60/24"x24" R</b>	<b>LG90</b>
	<b>30x60/12"x24" R</b>	<b>NG53</b>



<b>Oxyde</b>	<b>75x150/30"x60" R</b>	<b>LD68</b>
<b>Light</b>	<b>25x150/10"x60" R</b>	<b>LE88</b>
	<b>75x75/30"x30" R</b>	<b>LE49</b>
	<b>60x60/24"x24" R</b>	<b>LE57</b>
	<b>30x60/12"x24" R</b>	<b>NG51</b>



<b>Oxyde</b>	<b>75x150/30"x60" R</b>	<b>LD71</b>
<b>Light</b>	<b>25x150/10"x60" R</b>	<b>LE91</b>
<b>Strutt.</b>	<b>75x75/30"x30" R</b>	<b>LE51</b>



<b>Oxyde</b>	<b>75x150/30"x60" R</b>	<b>LD69</b>
<b>Dark</b>	<b>25x150/10"x60" R</b>	<b>LE89</b>
	<b>75x75/30"x30" R</b>	<b>LE48</b>
	<b>60x60/24"x24" R</b>	<b>LE58</b>
	<b>30x60/12"x24" R</b>	<b>NG50</b>



<b>Oxyde</b>	<b>75x150/30"x60" R</b>	<b>LD70</b>
<b>Rust</b>	<b>25x150/10"x60" R</b>	<b>LE90</b>
	<b>75x75/30"x30" R</b>	<b>LE50</b>
	<b>60x60/24"x24" R</b>	<b>LE59</b>
	<b>30x60/12"x24" R</b>	<b>NG52</b>

V3  
Moderate



V4  
Substantial \*



**Raw Light**    **75x150/30"x60" R**                    **LD63**  
                       **25x150/10"x60" R**                    **LE92**  
                       **75x75/30"x30" R**                        **LE52**  
                       **60x60/24"x24" R**                        **LE60**  
                       **30x60/12"x24" R**                        **NG55**



**Raw Grey**    **75x150/30"x60"R**                    **LD64**  
                       **25x150/10"x60" R**                    **LE93**  
                       **75x75/30"x30" R**                        **LE53**  
                       **60x60/24"x24" R**                        **LE61**  
                       **30x60/12"x24" R**                        **NG54**



**Raw Warm**    **75x150/30"x60"R**                    **LD65**  
                       **25x150/10"x60" R**                    **LE94**  
                       **75x75/30"x30" R**                        **LE54**  
                       **60x60/24"x24" R**                        **LE62**  
                       **30x60/12"x24" R**                        **NG56**



**Raw Mix \***    **75x150/30"x60"R**                    **LD66**  
                       **25x150/10"x60" R**                    **LE95**  
                       **75x75/30"x30" R**                        **LE55**  
                       **60x60/24"x24" R**                        **LE63**  
                       **30x60/12"x24" R**                        **NG58**

Decori/Decorative Motif/Decors/  
Dekore/Decoraties/Decoraciones



Raw	75x150/30"x60" R	LD67
Shadow	25x150/10"x60" R	LE96
Light	75x75/30"x30" R	LE56
	60x60/24"x24" R	LE64
	30x60/12"x24" R	NG57

Oxyde Light 60x60/24"x24" R — Oxyde Light 75x150/30"x60" R Strutt.



Pezzi speciali/Trim tiles/Pieces speciales/Formteile/Speziale delen/Piezas especiales

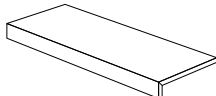
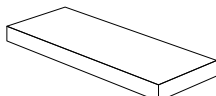

<b>Battiscopa</b> 	<b>7x75/2<sup>7/8</sup>"x30" R</b>		<b>7x60/2<sup>7/8</sup>"x24" R</b>	
	Oxyde Dark	<b>LF40</b>	Oxyde Dark	<b>LF33</b>
	Oxyde Light	<b>LF39</b>	Oxyde Light	<b>LF32</b>
	Oxyde Rust	<b>LF41</b>	Oxyde Rust	<b>LF34</b>
	Oxyde White	<b>LG84</b>	Oxyde White	<b>LG83</b>
	Raw Grey	<b>LF31</b>	Raw Grey	<b>LF28</b>
	Raw Light	<b>LF35</b>	Raw Light	<b>LF27</b>
	Raw Mix	<b>LF37</b>	Raw Mix	<b>LF30</b>
Raw Warm	<b>LF36</b>	Raw Warm	<b>LF29</b>	
<b>Scalino</b> 	<b>33x150/13"x60" R</b>			
	Oxyde Dark	<b>LG17</b>		
	Oxyde Light	<b>LG16</b>		
	Oxyde Rust	<b>LG18</b>		
	Oxyde White	<b>LG85</b>		
	Raw Grey	<b>LG20</b>		
	Raw Light	<b>LG19</b>		
Raw Mix	<b>LG22</b>			
Raw Warm	<b>LG21</b>			
<b>Scalino angolare</b> 	<b>33x150/13"x60" R</b>	<b>DX</b>	<b>33x150/13"x60" R</b>	<b>SX</b>
	Oxyde Dark	<b>NT15</b>	Oxyde Dark	<b>NT23</b>
	Oxyde Light	<b>NT16</b>	Oxyde Light	<b>NT24</b>
	Oxyde Rust	<b>NT17</b>	Oxyde Rust	<b>NT25</b>
	Oxyde White	<b>NT18</b>	Oxyde White	<b>NT26</b>
	Raw Grey	<b>NT19</b>	Raw Grey	<b>NT27</b>
	Raw Light	<b>NT20</b>	Raw Light	<b>NT28</b>
	Raw Mix	<b>NT21</b>	Raw Mix	<b>NT29</b>
	Raw Warm	<b>NT22</b>	Raw Warm	<b>NT30</b>

Imballi/Packing/Emballage/Verpackungseinheiten/Verpakking/Embalajes

	pcs x box	m <sup>2</sup> / m x box	kg x box	box x pallet	m <sup>2</sup> x pallet	kg x pallet
<b>75x150/30"x60"</b>	1	1,1250	24,50	25	28,13	612,50
<b>25x150/10"x60"</b>	3	1,1250	24,00	30	33,75	720,00
<b>75x75/30"x30"</b>	2	1,1250	24,00	42	47,25	1008,00
<b>60x60/24"x24"</b>	3	1,0800	21,35	40	43,20	854,00
<b>30x60/12"x24"</b>	7	1,2600	25,00	40	50,40	1000,00
<b>7x75/2<sup>7/8</sup>"x30" Battiscopa</b>	10	7,5000	11,00	54	405,00	594,00
<b>7x60/2<sup>7/8</sup>"x24" Battiscopa</b>	10	6,0000	9,00	70	420,00	630,00
<b>33x150/13"x60" Scalino</b>	2	0,9900	23,00	16	15,84	368,00
<b>33x150/13"x60" Scalino Ang.</b>	1	0,4950	11,50	16	7,92	184,00

Caratteristiche/Features/Caracteristiques/Eigenschaften/Eigenschappen/Características



UNI EN ISO 10545/14

Classe 5 / Class 5



DIN 51130

R9  
R10 Oxyde Light Strutt.



DIN 51097

A+B Oxyde Light Strutt.



B.C.R.A. Rep. CEC/81

Asciutto > 0,40 / Bagnato > 0,40



ANSI A137.1-2012 (BOT3000)

> 0,42 Wet



Beton Greige 30x30/12"x12" R



## Worn attitude

Mood shabby e atmosfere da loft metropolitano per una collezione articolata in due famiglie: il legno invecchiato Bois dal leggero effetto vintage, nei colori Beige, Brown, Grey e nei formati 25x150 e 22,5x90, e le classiche cementine Beton proposte in Almond, Greige, Shadow nei formati 60x60 e 30x30 (quest'ultimo con una stonalizzazione più marcata) completati da un decoro 30x30 in tutte le tonalità. La combinazione delle due superfici crea il cassettoni Inlay nelle gradazioni Warm e Cold in dimensioni 75x75: composto da una cornice in legno Bois che racchiude le cementine Beton, Inlay si può facilmente abbinare ad entrambi i prodotti per disegnare ambienti dinamici e di tendenza.

Shabby mood and metropolitan loft atmosphere for a collection available in two families: aged Bois wood sporting a light vintage effect in the colours Beige, Brown and Grey, in formats 25x150 and 22,5x90, and the classic Beton cement tiles available in Almond, Greige and Shadow in formats 60x60 and 30x30 (this last one with a more marked shade variation), completed by a 30x30 decoration in all colours. The combination of the two surfaces creates the Inlay coffer in Warm and Cold shades, size 75x75. Composed of a frame in Bois wood that encloses the Beton cement tiles, Inlay can easily be matched with both products to design dynamic, trendy environments.

Ambiance shabby et atmosphère de loft métropolitain pour une collection s'articulant en deux familles: le bois vieilli Bois au léger effet vintage, dans les couleurs Beige, Brown, Grey et dans les formats 25x150 e 22,5x90, et les carreaux ciment de Beton proposées en Almond, Greige, Shadow dans les formats 60x60 et 30x30 (ce dernier avec un nuançage plus marqué) complétées par un motif 30x30 dans toutes les nuances. Deux surfaces s'unissent dans le cassettoni Inlay dans les nuances Warm et Cold format 75x75: composé d'un cadre en bois Bois qui comprend les carreaux ciment Beton, Inlay s'assortit facilement aux deux produits pour créer des ambiances modernes et dynamiques.

Shabby-chic und Atmosphären eines städtischen Lofts prägen eine in zwei Familien gegliederte Kollektion: die gealterte Holzoptik von Bois mit leichter Vintage-Optik in den Farben Beige, Brown, Grey und den Formaten 25x150 und 22,5x90, sowie die klassischen Sechseckfliesen Beton in den Versionen Almond, Greige, Shadow, in 60x60 und 30x30 (letztere mit ausgeprägteren Farbschwankungen), die in allen Farbvarianten durch ein Dekor 30x30 ergänzt werden. Bei Kombination der beiden Oberflächen entsteht die Kassettoni Inlay in den Farbtönen Warm und Cold in der Größe 75x75. Hierbei wird ein Holzrahmen aus Bois mit den Sechskantfliesen Beton ausgefüllt. Inlay lässt sich einfach mit beiden Produkten kombinieren, um dynamische und trendige Räume zu gestalten.

Shabby moods en sferen als van een loft in een stad voor een collectie die uit twee families bestaat: het verouderde Bois-hout met een licht vintage-effect in de kleuren Beige, Brown, Grey en in de formaten 25x150 en 22,5x90, en de klassieke cementtegels Beton in de versies Almond, Greige en Shadow in de formaten 60x60 en 30x30 (laatstgenoemde met sterkere kleurcontrasten) aangevuld met een decoratie 30x30 in alle kleurnuances. Deze twee oppervlakken worden gecombineerd in het "cassette" Inlay in de gradaties Warm en Cold met afmetingen 75x75, dat bestaat uit een houten Bois-frame dat Beton-cementtegels omsluit. Inlay kan eenvoudig met beide producten worden gecombineerd om dynamische trendy ambiances te ontwerpen.

Mood shabby y atmósferas de loft metropolitano para una colección articulada en dos familias: madera envejecida Bois de suave efecto vintage, de colores Beige, Brown, Grey en los tamaños 25x150 y 22,5x90, y las clásicas cementinas Beton propuestas en Almond, Greige, Shadow de tamaño 60x60 y 30x30 (este último de sombreado marcado) con decoraciones 30x30 en todas las tonalidades. La combinación de dos superficies crea el cassetón Inlay en las gradaciones Warm y Cold tamaño 75x75: compuesto de un marco de madera Bois que encierra las cementinas Beton, Inlay se puede combinar fácilmente en ambos productos para diseñar ambientes dinámicos y de moda.

### Beton

± 9 mm

60x60/24"x24" R  
30x30/12"x12" R

### Bois

± 9 mm

25x150/10"x60" R  
22,5x90/9"x36" R

### Inlay

± 9 mm

75x75/30"x30" R

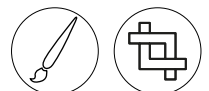

V3  
Moderate

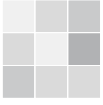

Beton Shadow 60x60/24"x24" R MG04



Beton Almond 60x60/24"x24" R MG02



Beton Greige 60x60/24"x24" R MG03

V4  
Substantial



Beton Shadow 30x30/12"x12" R NG80



Beton Almond 30x30/12"x12" R NG78



Beton Greige 30x30/12"x12" R NG79



**Beton  
Shadow  
Deco** 30x30/12"x12" R NG83



**Beton  
Almond  
Deco** 30x30/12"x12" R NG81



**Beton  
Greige  
Deco** 30x30/12"x12" R NG82

30 soggetti diversi formato 30x30 (miscelazione casuale)/  
30 assorted motifs 30x30 size (random mix)/  
30 sujets differents format 30x30 (melange aleatoire)/  
30 verschiedene Motive Format 30x30 (Zufallsmischung)/  
30 verschillende ontwerpen in 30x30 (willekeurig gemengd)/  
30 motivos diferentes formato 30x30 (mezcla casual)

**Beton Almond Deco 30x30/12"x12" R**



V3  
Moderate



Bois 25x150/10"x60" R MD65  
Grey 22,5x90/9"x36" R MF98



Bois 25x150/10"x60" R MD66  
Beige 22,5x90/9"x36" R MF96



Bois 25x150/10"x60" R MD67  
Brown 22,5x90/9"x36" R MF97

FFEE	2.5
PRESSO	2.5
CCHIATO	3
PPUCCINO	2.5
TTE	4
CHA	3
A	A.Q.
AI	4



V4  
Substantial



**Inlay Cold** 75x75/30"x30" R

**ME49**



**Inlay Warm** 75x75/30"x30" R

**ME48**

**Inlay Warm 75x75/30"x30" R**



**Inlay Cold** è composto da Bois Grey e Beton Shadow. **Inlay Warm** è composto da Bois Beige e Beton Greige.  
**Inlay Cold** is made of Bois Grey and Beton Shadow. **Inlay Warm** is made of Bois Beige and Beton Greige.  
**Inlay Cold** se compose de Bois Grey et Beton Shadow. **Inlay Warm** se compose de Bois Beige et Beton Greige.  
**Inlay Cold** ist zusammengesetzt aus Bois Grey und Beton Shadow. **Inlay Warm** ist zusammengesetzt aus Bois Beige und Beton Greige.  
**Inlay Cold** bestaat uit Bois Grey en Beton Shadow. **Inlay Warm** bestaat uit Bois Beige en Beton Greige.  
**Inlay Cold** está compuesto por Bois Grey y Beton Shadow. **Inlay Warm** está compuesto por Bois Beige y Beton Greige.

Pezzi speciali/Trim tiles/Pieces speciales/Formteile/Speciale delen/Piezas especiales



Battiscopa

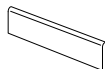

7x90/2<sup>7/8</sup>"x36" R

Bois Beige  
Bois Brown  
Bois Grey

**MF10**  
**MF11**  
**MF12**

7x60/2<sup>7/8</sup>"x24" R

Beton Almond  
Beton Greige  
Beton Shadow

**MF13**  
**MF14**  
**MF15**

Imballi/Packing/Emballage/Verpackungseinheiten/Verpakking/Embalajes

	pcs x box	m <sup>2</sup> / m x box	kg x box	box x pallet	m <sup>2</sup> x pallet	kg x pallet
25x150/10"x60"	3	1,1250	24,00	30	33,75	720,00
22,5x90/9"x36"	6	1,2150	25,80	36	43,74	928,80
75x75/30"x30"	2	1,1250	24,00	42	47,25	1008,00
60x60/24"x24"	3	1,0800	21,35	40	43,20	854,00
30x30/12"x12"	12	1,0800	20,50	48	51,84	984,00
30x30/12"x12" Deco	12	1,0800	20,50	48	51,84	984,00
7x90/2 <sup>7/8</sup> "x36" Battiscopa	6	5,4000	8,00	55	297,00	440,00
7x60/2 <sup>7/8</sup> "x24" Battiscopa	10	6,0000	9,00	70	420,00	630,00

Caratteristiche/Features/Caracteristiques/Eigenschaften/Eigenschappen/Características



UNI EN ISO 10545/14

Classe 5 / Class 5



DIN 51130

R10



DIN 51097

A+B Inlay



BS 7976-2:2002 (CEN/TS 16165, Annex C) Pendulum Friction Test

≥ 36 Wet



B.C.R.A. Rep. CEC/81

Asciutto > 0,40 /  
Bagnato > 0,40



ANSI A137.1-2012 (BOT3000)

> 0,42 Wet



Perle 120x120/48"x48" R



## Modern allure

Essence è una collezione dalla texture equilibrata ed elegante, ispirata a pietre naturali di origine centro-europea; si contraddistingue per la trama leggermente puntinata e ricca di delicate inclusioni fossili. È proposta nelle classiche colorazioni intense Fumée e Perle e nell'originale tono caldo Avane. Sviluppata per ambienti armoniosi e moderni, la collezione è disponibile anche con superficie strutturata, per pavimentazioni esterne che durano nel tempo.

Essence is a collection with a balanced and elegant texture. Inspired by natural stones of central European origin, it stands out for its slightly speckled texture and many delicate fossil inclusions. It is proposed in the classic and intense Fumée and Perle shades and the original, warm Avane tone. Created for harmonious, modern spaces, the collection is also available with a textured surface, ideal for long-lasting outdoor floor.

Essence est une collection à la texture équilibrée et élégante : inspirée de pierres naturelles d'Europe centrale, elle se caractérise par une trame légèrement pointillée et enrichie d'inclusions fossiles délicates. Elle est proposée dans les couleurs classiques Fumée et Perle intenses et dans la teinte chaude originale Avane. Conçue pour des espaces harmonieux et modernes, la collection est disponible également avec une surface texturisée, idéale pour des revêtements de sol extérieurs qui durent dans le temps.

Die Kollektion Essence besticht mit ausgewogen eleganten Texturen: Inspiriert von Natursteinen mitteleuropäischer Herkunft, zeichnet sie sich durch einen leicht gepunkteten Einschlag mit zarten fossilen Einschlüssen aus. Sie wird in den klassischen intensiven Farben Fumée und Perle und im warmen Grundton Avane angeboten. Die auf Dauerhaftigkeit ausgelegte Kollektion wurde für harmonische und moderne Umgebungen entwickelt und ist für den Außenbereich auch mit einer strukturierten Oberfläche erhältlich.

Essence is een collectie met een evenwichtige en elegante textuur: geïnspireerd op natuursteen van Midden-Europese oorsprong, valt zij op door de licht gestippelde structuur die rijk is aan delicate fossiele insluitsels. Zij wordt voorgesteld in de klassieke intense kleuren Fumée en Perle en in de originele warme tint Avane. Ontwikkeld voor een harmonieuze en moderne omgeving, is de collectie ook verkrijgbaar met een gestructureerd oppervlak, ideaal voor een duurzame buitenvloer.

Essence es una colección con una textura equilibrada y elegante: inspirada en las piedras naturales de origen centro-europeo, se distingue por su trama ligeramente punteada y abundantes inclusiones fósiles. Se propone en los clásicos tonos intensos Fumée y Perle así como en el original y cálido Avane. Diseñada para espacios armoniosos y modernos, la colección está disponible también con superficie estructurada, ideal para pavimentos de exterior destinados a durar en el tiempo.

✂ 9 mm

120x120/48"x48" R  
60x120/24"x48" R  
60x60/24"x24" R  
60x60/24"x24" R Strutt.

✂ 20 mm OUT2.0

60x60/24"x24" R Strutt.

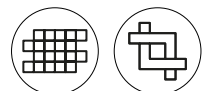

V2  
Slight



**Perle**    **120x120/48"x48" R**    **NM33**  
**60x120/24"x48" R**    **NM05**  
**60x60/24"x24" R**    **NM36**  
**60x60/24"x24" R Strutt.**    **NO35**  
**60x60/24"x24" R Strutt. OUT2.0**    **NR92**



**Fumée**    **120x120/48"x48" R**    **NM32**  
**60x120/24"x48" R**    **NM06**  
**60x60/24"x24" R**    **NM35**  
**60x60/24"x24" R Strutt.**    **NO34**



**Avane**    **120x120/48"x48" R**    **NM31**  
**60x120/24"x48" R**    **NM07**  
**60x60/24"x24" R**    **NM34**  
**60x60/24"x24" R Strutt.**    **NO33**  
**60x60/24"x24" R Strutt. OUT2.0**    **NR91**

Fumée 60x120/24"x48" R

Essence  
98/99





V2  
Slight



Perle 26×30/10"×24" NS56  
Mosaico



Fumée 26×30/10"×24" NS55  
Mosaico



Avane 26×30/10"×24" NS54  
Mosaico



Perle 30×58/12"×23" R NS59  
Muretto



Fumée 30×58/12"×23" R NS58  
Muretto



Avane 30×58/12"×23" R NS57  
Muretto



## Pezzi speciali/Trim tiles/Pieces speciales/Formteile/Speziale delen/Piezas especiales

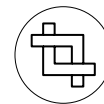

### Battiscopa

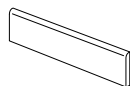

7x60/2<sup>7/8</sup>"x24" R

Avane **NM10**  
Perle **NM08**  
Fumée **NM09**

## Imballi/Packing/Emballage/Verpackungseinheiten/Verpakking/Embalajes

	pcs x box	m <sup>2</sup> / m x box	kg x Box	box x pallet	m <sup>2</sup> / m x pallet	kg x pallet
120x120/48"x48"	2	2,8800	58,00	20	57,60	1160,00
60x120/24"x48"	2	1,4400	31,50	35	50,40	1102,50
60x60/24"x24"	3	1,0800	21,35	40	43,20	854,00
30x58/12"x23" R Muretto	4	0,6960	10,70	21	14,62	224,70
26x30/10"x24" Mosaico	6	0,4680	10,75	60	28,08	645,00
60x60/24"x24" <b>OUT2.0</b>	2	0,7200	32,40	30	21,60	972,00
7x60/2 <sup>7/8</sup> "x24" Battiscopa	10	6,0000	9,00	70	420,00	630,00

## Caratteristiche/Features/Caracteristiques/Eigenschaften/Eigenschappen/Características



UNI EN ISO 10545/14

Classe 5 / Class 5



DIN 51130

R10  
R11 Strutt.  
R11 OUT2.0



DIN 51097

A+B



BS 7976-2:2002 (CEN/TS 16165,  
Annex C) Pendulum Friction Test

≥ 36 Wet



B.C.R.A. Rep. CEC/81

Asciutto > 0,40 /  
Bagnato > 0,40



ANSI A137.1-2012 (BOT3000)

> 0,42 Wet







## Timeless elements

La raffinatezza e il fascino del tradizionale terrazzo alla veneziana rivivono in veste contemporanea nella collezione Flake. Il terrazzo alla veneziana, materiale nato dall'unione di frammenti di marmo, pietre, componenti cementizi e ossidi naturali, è diffuso nelle residenze di pregio in tutto il mondo, dalla Venezia Rinascimentale fino ai palazzi signorili in stile liberty. In Flake, scaglie irregolari di ciottoli e marmi formano un pattern omogeneo e ricco di dettagli, disponibile in granulometria piccola (small) e media (medium), in toni freddi e toni caldi, favorendo abbinamenti in chiave contemporanea e giochi creativi tra volumi e superfici.

The sophistication and charm of traditional Venetian Terrazzo are brought back to life with a contemporary twist in the Flake collection. Venetian Terrazzo, a material resulting from the amalgamation of chips of marble, stones, cement components and natural oxides, is widespread in prestigious residences across the globe, from Venice during the Italian Renaissance to elegant Liberty-style buildings. In Flake, irregular chips of pebbles and marble make up an even pattern packed with details, available in small and medium grain size, in cold and warm hues, favouring contemporary combinations and creative games of volumes and surfaces.

Raffiné et séduisant, le revêtement traditionnel en granito est revisité en version contemporaine dans la collection Flake. Le revêtement traditionnel en granito, matériau unissant des fragments de marbre, pierres, ciment et oxydes naturels, est répandu dans les résidences de luxe du monde entier, de la Venise de la Renaissance aux palais seigneuriaux de style Art nouveau. Dans la collection Flake, des éclats irréguliers de pierres et de marbres forment un motif homogène et riche en détails qui est disponible en granulométrie fine (small) et moyenne (medium), dans des tons froids et chauds, favorisant les assortiments contemporains et les jeux créatifs entre les volumes et les surfaces.

Die traditionelle venezianischen Terrasse wird in all ihrer Kultiviertheit mit der Kollektion Flake zeitgemäß zu neuem Leben erweckt. I terrazzo alla veneziana [Terrasse im venezianischen Stil], ein Material, das aus Marmorsplittern, Naturstein, Zementteilen und natürlichen Oxiden entstanden ist, ist in prestigeträchtigen Residenzen auf der ganzen Welt zu finden; in Venedig sowohl im Renaissancestil als auch in den edelsten Jugendstil-Palästen. In Flake bilden unregelmäßige Stein- und Marmorteile ein homogenes, detailreiches Muster, das in kleinen und mittleren Körnungen (small und medium), in kalten und warmen Tönen erhältlich ist und trendige Kombinationen mit kreativen Volumen- und Oberflächenspielen schafft.

De verfijning en charme van het traditionele Venetiaanse terrazzo herleven in eigentijdse vorm in de collectie Flake. Het Venetiaanse terrazzo, een materiaal dat bestaat uit fragmenten van marmer en steen, cementcomponenten en natuurlijke oxides, is te vinden in prestigieuze residenties over de hele wereld, van het renaissancestische Venetië tot met de herenhuizen in libertystijl. In Flake vormen onregelmatige scherven van kiezelstenen en marmer een homogeen patroon, rijk aan details, leverbaar in een kleine (small) of middelgrote (medium) korrelgrootte, in koude en warme tinten, met de nadruk op eigentijdsheid en creatief spelen met volumes en oppervlakken.

La colección Flake rememora la sofisticación y el atractivo de la terraza tradicional veneciana en versión moderna. La terraza veneciana es un material nacido de la unión de fragmentos de mármol, piedra, componentes cementosos y óxidos naturales cuyo uso se extendió entre las prestigiosas viviendas de todo el mundo, desde la Venecia del Renacimiento hasta los palacios señoriales de estilo Liberty. En Flake, fragmentos irregulares de guijarros y mármoles forman un patrón homogéneo y exuberante en detalles, disponible en granulometría pequeña (small) y media (medium), en colores fríos y cálidos que crean mezclas modernas y juegos creativos entre volúmenes y superficies.

9 mm

60x60/24"x24" R  
60x60/24"x24" Soft R  
60x60/24"x24" Lapp R

Gres porcellanato  
Porcelain stoneware  
Grès cérame fin vitrifié  
Feinsteinzeug  
Porseleingres  
Gres porcelánico

V2  
Slight

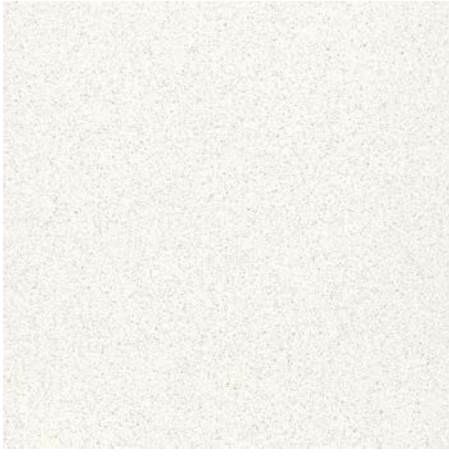

**White Small**      **60x60/24"x24" R**      **MK72**  
**60x60/24"x24" Soft R**      **MK71**  
**60x60/24"x24" Lapp R**      **NC17**



**White Medium**      **60x60/24"x24" R**      **MK64**  
**60x60/24"x24" Soft R**      **MK63**  
**60x60/24"x24" Lapp R**      **NC13**

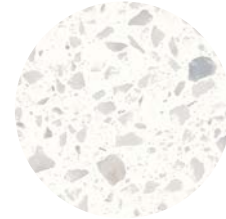

**White Small**



**White Medium**



**Beige Small**      **60x60/24"x24" R**      **MK66**  
**60x60/24"x24" Soft R**      **MK65**  
**60x60/24"x24" Lapp R**      **NC14**



**Beige Medium**      **60x60/24"x24" R**      **MK58**  
**60x60/24"x24" Soft R**      **MK57**  
**60x60/24"x24" Lapp R**      **NC10**

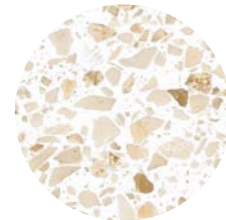

**Beige Small**

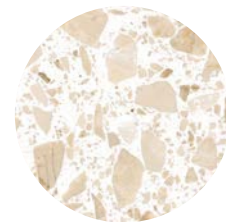

**Beige Medium**

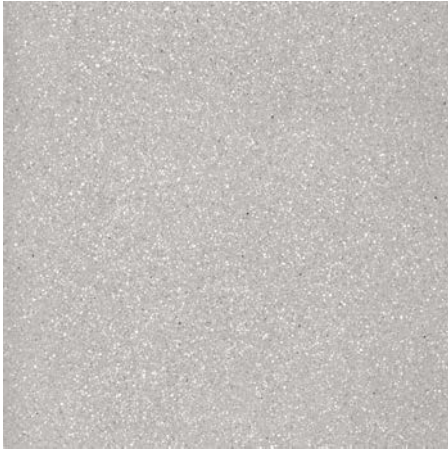

**Light Small**  
60x60/24"x24" R  
60x60/24"x24" Soft R  
60x60/24"x24" Lapp R  
MK70  
MK69  
NC16



**Light Medium**  
60x60/24"x24" R  
60x60/24"x24" Soft R  
60x60/24"x24" Lapp R  
MK62  
MK61  
NC12

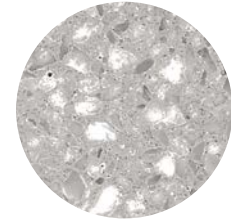

Light Small



Light Medium

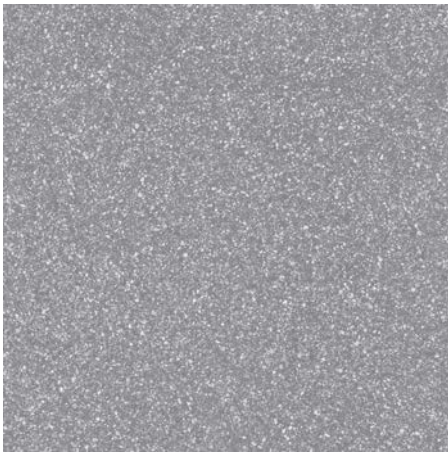

**Dark Small**  
60x60/24"x24" R  
60x60/24"x24" Soft R  
60x60/24"x24" Lapp R  
MK68  
MK67  
NC15



**Dark Medium**  
60x60/24"x24" R  
60x60/24"x24" Soft R  
60x60/24"x24" Lapp R  
MK60  
MK59  
NC11

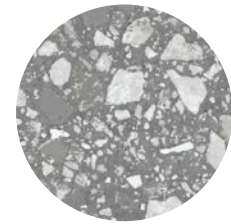

Dark Small

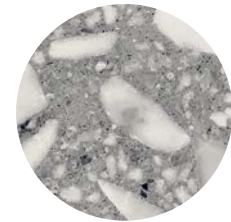

Dark Medium



**Black Small**  
60x60/24"x24" R  
60x60/24"x24" Soft R  
60x60/24"x24" Lapp R  
ND94  
ND95  
ND89

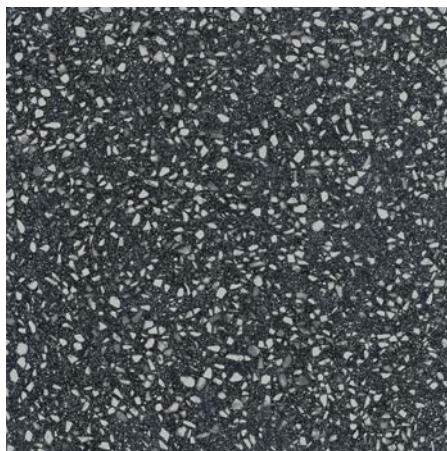

**Black Medium**  
60x60/24"x24" R  
60x60/24"x24" Soft R  
60x60/24"x24" Lapp R  
ND92  
ND93  
ND88

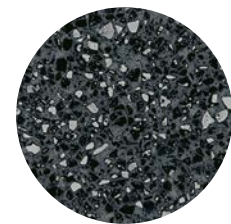

Black Small

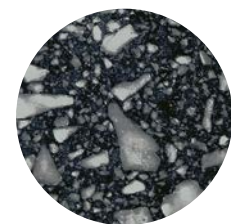

Black Medium

## Pezzi speciali/Trim tiles/Pieces speciales/Formteile/Speciale delen/Piezas especiales



### Battiscopa



7x60/2 <sup>7/8</sup> "x24" R		7x60/2 <sup>7/8</sup> "x24" R	
Beige Medium	<b>MK73</b>	Beige Small	<b>MK77</b>
Black Medium	<b>ND86</b>	Black Small	<b>ND87</b>
Dark Medium	<b>MK74</b>	Dark Small	<b>MK78</b>
Light Medium	<b>MK75</b>	Light Small	<b>MK79</b>
White Medium	<b>MK76</b>	White Small	<b>MK80</b>
7x60/2 <sup>7/8</sup> "x24" Lapp R		7x60/2 <sup>7/8</sup> "x24" Lapp R	
Beige Medium	<b>NC18</b>	Beige Small	<b>NC22</b>
Black Medium	<b>ND84</b>	Black Small	<b>ND85</b>
Dark Medium	<b>NC19</b>	Dark Small	<b>NC23</b>
Light Medium	<b>NC20</b>	Light Small	<b>NC24</b>
White Medium	<b>NC21</b>	White Small	<b>NC25</b>

## Imballi/Packing/Emballage/Verpackungseinheiten/Verpakking/Embalajes

	pcs x box	m <sup>2</sup> / m x box	kg x box	box x pallet	m <sup>2</sup> x pallet	kg x pallet
60x60/24"x24"	3	1,0800	21,35	40	43,20	854,00
7x60/2 <sup>7/8</sup> "x24" Battiscopa	10	6,0000	9,00	70	420,00	630,00

The MATT and SOFT finishes are recommended for interior floors, walls, and exterior walls in both residential and commercial applications. Flake is not recommended for exterior horizontal surfaces or exterior paving, and they are not recommended for ramps application. The SOFT finish is not recommended for interior floors in entrance areas if joined to outdoor in commercial applications.

Flake LAPPATO is recommended for interior walls and exterior walls in both residential and commercial applications. Flake LAPPATO finish is not recommended for floors.

## SOFT Caratteristiche/Features/Caracteristiques/Eigenschaften/Eigenschappen/Características



UNI EN ISO 10545/14

Classe 5 / Class 5



B.C.R.A. Rep. CEC/81

Asciutto > 0,40 / Bagnato > 0,40



ANSI A137.1-2012 (BOT3000)

> 0,42 Wet

## MATT Caratteristiche/Features/Caracteristiques/Eigenschaften/Eigenschappen/Características



UNI EN ISO 10545/14

Classe 5 / Class 5



DIN 51130

R10



DIN 51097

A+B



BS 7976-2:2002 (CEN/TS 16165, Annex C) Pendulum Friction Test

≥ 36 Wet



B.C.R.A. Rep. CEC/81

Asciutto > 0,40 /  
Bagnato > 0,40



ANSI A137.1-2012 (BOT3000)

> 0,42 Wet

I valori indicati nella tabella si riferiscono a superfici naturali (non lappate)/The values in the table refer to natural (not honed) surfaces/Les valeurs du tableau se rapportent à des surfaces naturelle (non adoucis)/Die in der Tabelle angeführten Werte beziehen sich auf naturbelassene (nicht geläppte) Oberflächen/Los valores indicados en la tabla se refieren a las superficies naturales (no recubiertas)

Beige Small 60x60/24"x24" R — White Small 60x60/24"x24" R — Beige Medium 60x60/24"x24" R

Flake  
108/109



Corten 120x120/48"x48" R — Burnish 120x278/48"x110" R



## The fascination of crafted metal

Il grès porcellanato declina con nuova potenza estetica materiali metallici di diverse origini. Aluminium, Titanium e Burnish nascono dall'osservazione di una particolare tecnica artigianale, quella dei battilastra. La collezione è caratterizzata quindi da segni e scalfiture originati dalle lavorazioni a mano. Corten e Verdigris traggono invece ispirazione dai metalli ossidati e ripropongono aloni e macchie derivate dall'azione di ruggine e acidi.

Porcelain stoneware interprets metallic materials from various origins with a brand new styling effect. Aluminium, Titanium and Burnish are the result of observing a specific craft-based technique, specifically the one used by bending machine operators: the collection thus stands out for its markings and scorings originating by the hand-crafting processes. Corten and Verdigris on the other hand draw their inspiration from oxidised metals and replicate the ring marks and stains deriving from the action of rust and acids.

Le grès cérame offre une nouvelle puissance esthétique à des matériaux métalliques d'origines variées. Aluminium, Titanium et Burnish s'inspirent d'une technique artisanale particulière, celle du tôlier : la collection est donc caractérisée par les marques et les éraflures typiques des façonnages à la main. Corten et Verdigris puisent quant à elles leur inspiration des métaux oxydés, reproduisant les halos et les taches provenant de l'action de la rouille et des acides.

Feinsteinzeug verleiht metallischen Werkstoffen unterschiedlicher Herkunft eine neue ästhetische Kraft. Aluminium, Titanium und Burnish sind das Ergebnis der Beobachtung der Handwerkstechnik der Klempner: Die Kollektion zeichnet sich daher durch Zeichen und Kratzer aus, die aus handgefertigten Arbeiten stammen. Corten und Verdigris inspirieren sich dagegen an den oxidierten Metallen und geben Schimmer und Flecken wieder, die durch Rost und Säure hervorgerufen werden.

Gres porcellanato krijgt een nieuwe esthetische entiteit met metalen materialen van verschillende oorsprong. Aluminium, Titanium en Burnish zijn het resultaat van de observatie van ambachtelijke plaatbewerking: de collectie vertoont tekens en krassen die getuigen van de ambachtelijke fabricatie. Corten en Verdigris daarentegen laten zich bezielen door geoxideerde metalen en suggereren opnieuw tinten en stains afkomstig van de inwerking van roest en zuren.

El gres porcelánico aporta un nuevo poder estético al jugar con materiales metálicos de distinto origen. Aluminium, Titanium y Burnish nacen de observar la técnica artesanal de los chapistas: la colección se caracteriza precisamente por presentar las marcas y mellas características de un trabajo manual. En cambio, Corten y Verdigris se inspiran en el metal oxidado y reproducen los halos y las manchas derivadas de la acción del óxido y los ácidos.

✂ 6 mm

120x278/48"x110" R

✂ 9 mm

120x120/48"x48" R  
60x120/24"x48" R  
60x60/24"x24" R  
30x60/12"x24" R





V2  
Slight

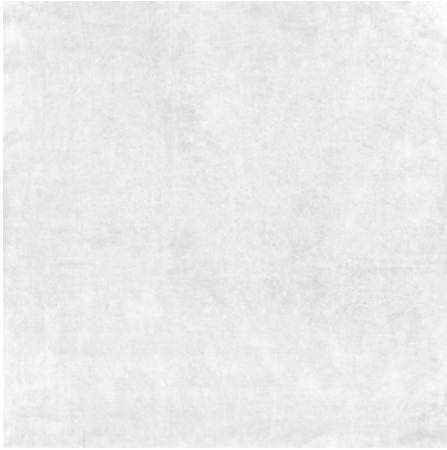

**Aluminium** 120x278/48"x110" R NP41  
120x120/48"x48" R NQ99  
60x120/24"x48" R NQ33  
60x60/24"x24" R NQ38  
30x60/12"x24" R NQ43

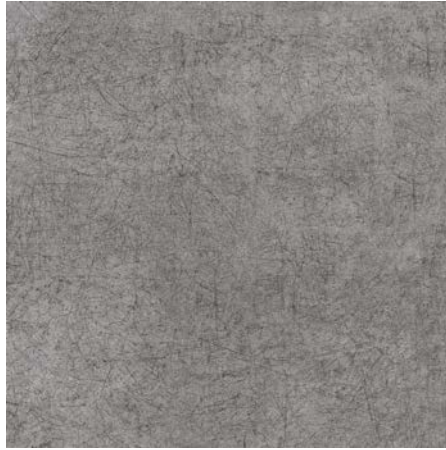

**Titanium** 120x120/48"x48" R NP02  
60x120/24"x48" R NQ36  
60x60/24"x24" R NQ41  
30x60/12"x24" R NQ46

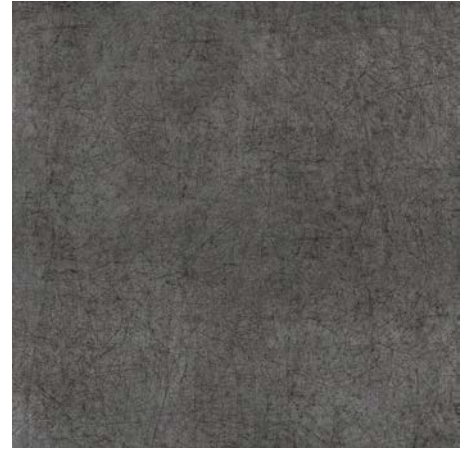

**Burnish** 120x278/48"x110" R NP42  
120x120/48"x48" R NP00  
60x120/24"x48" R NQ34  
60x60/24"x24" R NQ39  
30x60/12"x24" R NQ44



**Corten** 120x120/48"x48" R NP01  
60x120/24"x48" R NQ35  
60x60/24"x24" R NQ40  
30x60/12"x24" R NQ45



**Verdigris** 120x120/48"x48" R NP03  
60x120/24"x48" R NQ37  
60x60/24"x24" R NQ42  
30x60/12"x24" R NQ47

Titanium 120×120/48"×48" R — Burnish 120×278/48"×110" R

Foil  
112/113



## Pezzi speciali/Trim tiles/Pieces speciales/Formteile/Speciale delen/Piezas especiales

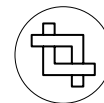

### Battiscopa

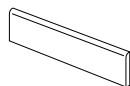

7x60/2<sup>7/8</sup>"x24" R

Aluminium	NP13
Burnish	NP14
Corten	NP15
Titanium	NP16
Verdigris	NP17

## Imballi/Packing/Emballage/Verpackungseinheiten/Verpakking/Embalajes

	pcs x box	m <sup>2</sup> / m x box	kg x Box	box x pallet	m <sup>2</sup> / m x pallet	kg x pallet
120x278/48"x110"	1	3,3360	49,56	18	60,05	892,08
120x120/48"x48"	2	2,8800	58,00	20	57,60	1160,00
60x120/24"x48"	2	1,4400	31,50	35	50,40	1102,50
60x60/24"x24"	3	1,0800	21,35	40	43,20	854,00
30x60/12"x24"	7	1,2600	25,00	40	50,40	1000,00
7x60/2 <sup>7/8</sup> "x24" Battiscopa	10	6,0000	9,00	70	420,00	630,00

## Caratteristiche/Features/Caracteristiques/Eigenschaften/Eigenshappen/Características



UNI EN ISO 10545/14

Classe 5 / Class 5



DIN 51130

R10



BS 7976-2:2002 (CEN/TS 16165,  
Annex C) Pendulum Friction Test

≥ 36 Wet



B.C.R.A. Rep. CEC/81

Asciutto > 0,40 /  
Bagnato > 0,40



ANSI A137.1-2012 (BOT3000)

> 0,42 Wet



Rosato 120x120/48"x48" R



# Fornace

# 116/117

## Contemporary warmth

La memoria delle pavimentazioni in cotto rivive in chiave moderna nella collezione Fornace che interpreta un gusto di matrice rustica, attualizzandolo attraverso superfici essenziali e formati contemporanei. La palette cromatica dai toni caldi e sensoriali conferisce agli ambienti un'atmosfera di nuova familiarità e fascino senza tempo.

The memories of cotto flooring have been reproduced with a modern twist in the Fornace collection which interprets a rustic matrix taste, modernising it through elemental surfaces and contemporary sizes. The colour palette with its warm and sensory hues lends the surroundings an atmosphere with a new familiarity and timeless charm.

La tradition des sols en terre cuite est remise au goût du jour dans la collection Fornace, qui interprète cette matrice rustique en l'actualisant à travers des surfaces essentielles et des formats contemporains. La palette de couleurs, avec ses tons chauds et sensoriels, confère aux pièces une ambiance familiale renouvelée et un charme hors du temps.

Die Kollektion Fornace haucht den Terrakotta-Böden in moderner Aufmachung neues Leben ein - mit der rustikalen Interpretation werden essentielle Oberflächen in zeitgenössischen Formaten auf den neuesten Stand gebracht. Die Palette mit warmen, stimmungsvollen Farben verleiht den Räumen eine neue familiäre Atmosphäre und zeitlosen Charme.

Terracotta vloeren kennen een nieuw leven in de Fornace-collectie, die een rustieke smaak interpreteert en deze door middel van essentiële oppervlakken en eigentijdse formaten actualiseert. Het warme, sensuele kleurenpalet zorgt voor een nieuwe vertrouwde sfeer en een tijdloze charme in de kamers.

La memoria de los suelos de terracota sigue viva en clave moderna en la colección Fornace, que reinterpreta y actualiza el estilo rústico a través de superficies esenciales y formatos contemporáneos. La paleta de colores con tonos cálidos y sensoriales brinda a los ambientes una atmósfera de renovada familiaridad y belleza atemporal.

✂ 9 mm

120x120/48"x48" R  
60x120/24"x48" R  
60x60/24"x24" R  
60x60/24"x24" GRIP R  
30x60/12"x24" R

✂ 20 mm OUT2.0

90x90/36"x36" R

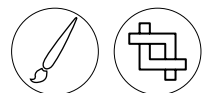

Gres porcellanato  
Porcelain stoneware  
Grès cérame fin vitrifié  
Feinsteinzeug  
Porseleingres  
Gres porcelánico

V3  
Moderate

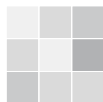

**Avorio** 120x120/48"x48" R NP04  
60x120/24"x48" R NQ48  
60x60/24"x24" R NQ53  
60x60/24"x24" GRIP R NR93  
30x60/12"x24" R NQ58



**Tortora** 120x120/48"x48" R NP07  
60x120/24"x48" R NQ52  
60x60/24"x24" R NQ56  
60x60/24"x24" GRIP R NR96  
30x60/12"x24" R NQ61



**Terra** 120x120/48"x48" R NP06  
60x120/24"x48" R NQ51  
60x60/24"x24" R NQ55  
60x60/24"x24" GRIP R NR95  
30x60/12"x24" R NQ60



**Zafferano** 120x120/48"x48" R NP08  
60x120/24"x48" R NQ49  
60x60/24"x24" R NQ57  
60x60/24"x24" GRIP R NR97  
30x60/12"x24" R NQ62  
90x90/36"x36" R OUT 2.0 NQ27



**Rosato** 120x120/48"x48" R NP05  
60x120/24"x48" R NQ50  
60x60/24"x24" R NQ54  
60x60/24"x24" GRIP R NR94  
30x60/12"x24" R NQ59  
90x90/36"x36" R OUT 2.0 NQ26

Zafferano 120x120/48"x48" R







- 11 Soggetti diversi formato 60x60 (miscelazione casuale)/
- 11 Assorted motifs 60x60size (random mix)/
- 11 Sujets differents format 60x60 (melange aleatoire)/
- 11 Verschiedene Motive Format 60x60 (Zufallsmischung)/
- 11 Verschillende ontwerpen in 60x60 (willekeurig gemengd)/
- 11 Motivos diferentes formato 60x60 (mezcla aleatoria)

Amalfi 60x60/24"x24" R

NQ86

Amalfi 60x60/24"x24" R





## Pezzi speciali/Trim tiles/Pieces speciales/Formteile/Speciale delen/Piezas especiales

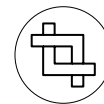

### Battiscopa

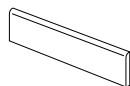

7x60/2<sup>7/8</sup>"x24" R

Avorio	<b>NP18</b>
Rosato	<b>NP19</b>
Terra	<b>NP20</b>
Tortora	<b>NP21</b>
Zafferano	<b>NP22</b>

## Imballi/Packing/Emballage/Verpackungseinheiten/Verpakking/Embalajes

	pcs x box	m <sup>2</sup> / m x box	kg x Box	box x pallet	m <sup>2</sup> / m x pallet	kg x pallet
120x120/48"x48"	2	2,8800	58,00	20	57,60	1160,00
60x120/24"x48"	2	1,4400	31,50	35	50,40	1102,50
60x60/24"x24"	3	1,0800	21,35	40	43,20	854,00
30x60/12"x24"	7	1,2600	25,00	40	50,40	1000,00
90x90/36"x36" <b>OUT2.0</b>	1	0,8100	37,60	18	14,58	676,80
60x60/24"x24" Amalfi	3	1,0800	21,35	40	43,20	854,00
7x60/2 <sup>7/8</sup> "x24" Battiscopa	10	6,0000	9,00	70	420,00	630,00

## Caratteristiche/Features/Caracteristiques/Eigenschaften/Eigenshappen/Características



UNI EN ISO 10545/14

Classe 5 / Class 5



DIN 51130

R10  
R11 GRIP  
R11 OUT2.0



DIN 51097

A+B+C OUT2.0



BS 7976-2:2002 (CEN/TS 16165, Annex C) Pendulum Friction Test

≥ 36 Wet



B.C.R.A. Rep. CEC/81

Asciutto > 0,40 /  
Bagnato > 0,40



ANSI A137.1-2012 (BOT3000)

> 0,42 Wet

Avorio 60x60/24"x24" R—  
Zafferano 90x90/36"x36" R OUT2.0

Fornace  
122/123



White 30x60/12"x24" R — White Mosaico 30x30/12"x12" R



## Graphic touch

Dalla ricerca Refin nasce una collezione ispirata alla pietra Zebrano: una matrice tradizionale tradotta con appeal contemporaneo definisce superfici versatili adatte all'utilizzo in tutti gli ambienti moderni.

Le ceramiche Fusion ricreano la forte direzionalità caratteristica della pietra naturale e della sua stratigrafia e la valorizzano attraverso la leggerezza dei movimenti, delle linee geometriche e dei passaggi di colore.

Refin research has developed this collection inspired by Zebrano stone: a traditional look translated with a contemporary appeal that creates versatile surfaces suitable for use in all modern environments.

Fusion ceramic tiles recreate the strong grain characteristic of natural stone and its layering and enhance it through light movements, geometric lines and colour transitions.

La recherche Refin a débouché sur une collection inspirée de la pierre Zebrano : une empreinte traditionnelle actualisée par un attrait contemporain définit des surfaces polyvalentes pouvant être utilisées dans tous les environnements modernes. Les céramiques Fusion recréent les fortes directions typiques de la pierre naturelle et de sa stratigraphie et la mettent en valeur par la légèreté des mouvements, les lignes géométriques et les transitions de couleurs.

Aus der Refin-Forschung kommt diese am Zebrano-Stein inspirierte Kollektion: Eine traditionelle Form definiert vielseitige Beläge in zeitgemäßer Optik, die sich für alle modernen Räume eignen. Die Fliesen der Kollektion Fusion geben die ausgeprägt richtungsgebundene Grafik des Natursteins und seiner Schichtungen wieder, die durch die Leichtigkeit der Bewegungen, der geometrischen Linien und der Farbübergänge noch unterstrichen wird.

Uit het onderzoek van Refin is een collectie ontstaan, die geïnspireerd is op de Zebrano-steen: een traditionele uitstraling definieert veelzijdige oppervlakken die geschikt zijn voor gebruik in alle moderne ruimtes. Fusion-tegels bootsen de sterke richtingsgevoeligheid na, die kenmerkend is voor natuursteen en zijn stratigrafie en versterkt deze door de lichtheid van de bewegingen, de geometrische lijnen en de kleurovergangen.

De la investigación de Refin surge una colección inspirada en la piedra zebrano: una matriz tradicional traducida con un atractivo contemporáneo define superficies versátiles adecuadas para su uso en todos los ambientes modernos. Las cerámicas Fusion recrean la fuerte direccionalidad característica de la piedra natural y su estratigrafía y la realzan a través de la ligereza de los movimientos, las líneas geométricas y las transiciones de color.

9 mm

30x60/12"x24" R

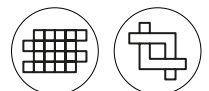

Fondi/Plain Tiles/Fonds/  
Grundfliesen/Fondsen/Fondos

V2  
Slight



White 30x60/12"x24" R NG64

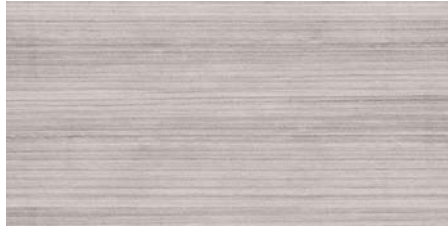

Ash 30x60/12"x24" R NG59



Grey 30x60/12"x24" R NG63



Black 30x60/12"x24" R NG61



Beige 30x60/12"x24" R NG60



Brown 30x60/12"x24" R NG62



V2  
Slight

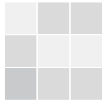

**White Mosaico** 30x30/12"x12" R MF49



**Ash Mosaico** 30x30/12"x12" R MF44



**Grey Mosaico** 30x30/12"x12" R MF48



**Black Mosaico** 30x30/12"x12" R MF46



**Beige Mosaico** 30x30/12"x12" R MF45



**Brown Mosaico** 30x30/12"x12" R MF47



**White Mosaico Intreccio** 30x30/12"x12" R MF55



**Ash Mosaico Intreccio** 30x30/12"x12" R MF50



**Grey Mosaico Intreccio** 30x30/12"x12" R MF54



**Black Mosaico Intreccio** 30x30/12"x12" R MF52



**Beige Mosaico Intreccio** 30x30/12"x12" R MF51



**Brown Mosaico Intreccio** 30x30/12"x12" R MF53



## Pezzi speciali/Trim tiles/Pieces speciales/Formteile/Speciale delen/Piezas especiales



### Battiscopa

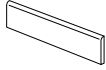

7x60/2<sup>7/8</sup>"x24" R

Ash	<b>MF38</b>
Beige	<b>MF39</b>
Black	<b>MF40</b>
Brown	<b>MF41</b>
Grey	<b>MF42</b>
White	<b>MF43</b>

## Imballi/Packing/Emballage/Verpackungseinheiten/Verpakking/Embalajes

	pcs x box	m <sup>2</sup> / m x box	kg x box	box x pallet	m <sup>2</sup> x pallet	kg x pallet
30x60/12"x24"	7	1,2600	25,00	40	50,40	1000,00
30x30/12"x12" Mosaico	11	0,9900	20,60	18	17,82	370,80
30x30/12"x12" Intreccio	6	0,5400	10,50	60	32,40	630,00
7x60/2 <sup>7/8</sup> "x24" Battiscopa	10	6,0000	9,00	70	420,00	630,00

## Caratteristiche/Features/Caracteristiques/Eigenschaften/Eigenshappen/Características



UNI EN ISO 10545/14

Classe 5 / Class 5



DIN 51130

R9 White, Beige  
R10 Ash



BS 7976-2:2002 (CEN/TS 16165, Annex C)  
Pendulum Friction Test

≥ 36 Wet



B.C.R.A. Rep. CEC/81

Asciutto > 0,40 /  
Bagnato > 0,40



ANSI A137.1-2012 (BOT3000)

> 0,42 Wet



Smoke 60x60/24"x24" R — Grey 30x60/12"x24" R



## Essential nature

L'energia e la solidità della natura vengono narrate attraverso Gaja: collezione che trae ispirazione dalla forza e dalla raffinatezza di una pietra quarzite proveniente dall'Oriente. La serie deve il suo nome a Gaia, la dea primordiale personificante la Terra, che nella mitologia greca è progenitrice del cielo, delle montagne, del mare e del tempo. La texture essenziale e pura di Gaja, disponibile in molti formati (45x90, 45x45, 60x60, 30x60, 30x30) e quattro nuances delicate, consente di coniugare il fascino di un materiale naturale con il rigore dell'architettura contemporanea, dando vita ad ambienti armoniosi. Completa la serie il muretto 3D che alterna diverse altezze, in un gioco geometrico di bassorilievi.

The energy and solidity of nature come to life through Gaja, a collection drawing its inspiration from the power and sophistication of quartzite sourced from the east. The series owes its name to Gaia, the primordial goddess embodying the Earth, which in Greek mythology was the mother of the sky, mountains, the sea and time. Gaja's pure and essential texture is available in a broad range of sizes (45x90, 45x45, 60x60, 30x60, 30x30) and four delicate hues; it allows to match the charm of a natural material with the rigorous proportions of contemporary architecture, resulting in harmonious compositions. The 3D wall completes the series, with alternating heights in a geometrical bas-relief effect.

Gaja évoque l'énergie et la solidité de la nature : cette collection puise son inspiration dans la force et le raffinement d'une variété de quartzite provenant de l'Orient. La série doit son nom à Gaïa, la déesse primordiale qui personnifie la Terre dans la mythologie grecque, créatrice du ciel, de la mer, des montagnes et du temps. La texture pure et sobre de Gaja, disponible dans de nombreux formats (45x90, 45x45, 60x60, 30x60, 30x30) et déclinée dans quatre tonalités délicates, permet d'allier le charme d'un matériel naturel à la rigueur de l'architecture contemporaine, pour créer des espaces harmonieux. La série est complétée par le muret 3D qui alterne différentes hauteurs dans un jeu géométrique de bas-reliefs.

Die Energie und die Solidität der Natur werden über Gaja erzählt: eine Kollektion, die ihre Inspiration aus der Kraft und Raffinesse eines aus dem Osten stammenden Quarzitsteins bezieht. Die Serie ist nach Gaja benannt, der die Erde personifizierenden urweltlichen Göttin, die in der griechischen Mythologie die Urahnin des Himmels, der Berge, des Meeres und der Zeit ist. Die essentielle und reine Texture von Gaja ist in vielen Formaten verfügbar (45x90, 45x45, 60x60, 30x60, 30x30) sowie in vier delikaten Nuancen und ermöglicht es, die Faszination eines natürlichen Materials mit der Strenge der zeitgenössischen Architektur zu vereinen und daraus harmonische Ambiente entstehen zu lassen. Vervollständigt wird die Serie von der kleinen 3D Mauer, bei welcher sich in einem geometrischen Basrelief-Spiel verschiedene Höhen abwechseln.

De energie en soliditeit van de natuur worden verteld door Gaja: een collectie geïnspireerd op de kracht en verfijning van een kwartsietsteen uit het Oosten. De collectie dankt haar naam aan Gaja, de oergodin die de aarde belichaamt en in de Griekse mythologie de stammoeder is van de hemel, de bergen, de zee en de tijd. De essentiële en pure textuur van Gaja, verkrijgbaar in vele formaten (45x90, 45x45, 60x60, 30x60, 30x30) en vier delicate nuances, maakt het mogelijk om de charme van een natuurlijk materiaal te combineren met de strengheid van de hedendaagse architectuur en zo harmonieuze omgevingen te creëren. De serie wordt vervolledigd door de 3D-muretto tegels die verschillende hoogtes afwisselen, in een geometrisch spel van bas-reliëfs.

La energía y la solidez de la naturaleza están expresadas en Gaja: la colección inspirada en la fuerza y elegancia de una piedra cuarcita llegada del Oriente. La serie debe su nombre a Gaia, la diosa primigenia, personificación de la madre Tierra, que en la mitología griega es progenitora del cielo, de las montañas, del mar y del tiempo. La textura esencial y pura de Gaja, disponible en diferentes formatos (45x90, 45x45, 60x60, 30x60, 30x30) y cuatro colores suaves, permiten conjugar el encanto de un material natural con el rigor de la arquitectura contemporánea, creando ambientes armoniosos. Completa la serie la pared 3D que alterna diferentes alturas, en un juego geométrico de bajorrelieves.

✂ 9 mm

45x90/18"x36" R  
60x60/24"x24" R  
30x60/12"x24" R  
30x30/12"x12"

✂ 9,5 mm

45x45/18"x18"

✂ 20 mm OUT2.0

90x90/36"x36" R  
60x60/24"x24" R

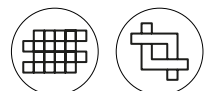

V2  
Slight



**Ivory**

45x90/18"x36" R	MW08
60x60/24"x24" R	MW67
30x60/12"x24" R	MW71
45x45/18"x18"	MX17
30x30/12"x12"	MW75



**Grey**

45x90/18"x36" R	MW07
60x60/24"x24" R	MW68
30x60/12"x24" R	MW72
45x45/18"x18"	MX18
30x30/12"x12"	MW76
90x90/36"x36" R OUT2.0	MZ49
60x60/24"x24" R OUT2.0	MZ47



**Smoke**

45x90/18"x36" R	MW10
60x60/24"x24" R	MW70
30x60/12"x24" R	MW74
45x45/18"x18"	MX20
30x30/12"x12"	MW78
90x90/36"x36" R OUT2.0	MZ50
60x60/24"x24" R OUT2.0	MZ48



**Sand**

45x90/18"x36" R	MW09
60x60/24"x24" R	MW69
30x60/12"x24" R	MW73
45x45/18"x18"	MX19
30x30/12"x12"	MW77



V2  
Slight

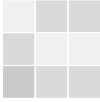

**Ivory** 31,5x45/12<sup>3/8</sup>"x18" R **MX00**  
**Muretto 3D**

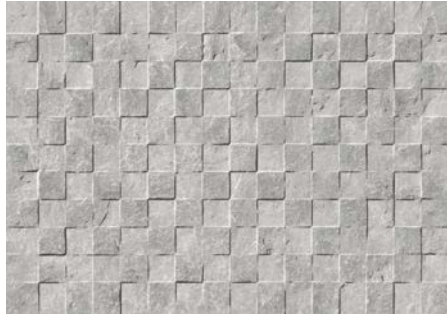

**Grey** 31,5x45/12<sup>3/8</sup>"x18" R **MX01**  
**Muretto 3D**

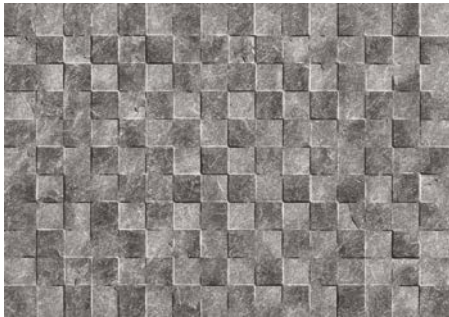

**Smoke** 31,5x45/12<sup>3/8</sup>"x18" R **MX03**  
**Muretto 3D**



**Sand** 31,5x45/12<sup>3/8</sup>"x18" R **MX02**  
**Muretto 3D**

## Pezzi speciali/Trim tiles/Pieces speciales/Formteile/Speciale delen/Piezas especiales

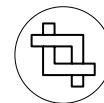

### Battiscopa

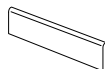

7x60/2<sup>7/8</sup>"x24" R

Ivory  
Grey  
Sand  
Smoke

**MW84**  
**MW85**  
**MW86**  
**MW87**

8,5x45/3<sup>1/2</sup>"x18"

Ivory  
Grey  
Sand  
Smoke

**MY79**  
**MY78**  
**MY80**  
**MY81**

## Imballi/Packing/Emballage/Verpackungseinheiten/Verpakking/Embalajes

	pcs x box	m <sup>2</sup> / m x box	kg x box	box x pallet	m <sup>2</sup> x pallet	kg x pallet
45x90/18"x36"	3	1,2150	25,00	36	43,74	900,00
60x60/24"x24"	3	1,0800	21,35	40	43,20	854,00
30x60/12"x24"	7	1,2600	25,00	40	50,40	1000,00
45x45/18"x18"	5	1,0125	20,60	33	33,41	679,80
30x30/12"x12"	12	1,0800	20,50	48	51,84	984,00
90x90/36"x36" OUT2.0	1	0,8100	37,60	18	14,58	676,80
60x60/24"x24" OUT2.0	2	0,7200	32,40	30	21,60	972,00
31,5x45/12 <sup>3/8</sup> "x18" Muretto 3D	6	0,8505	21,00	52	44,23	1092,00
7x60/2 <sup>7/8</sup> "x24" Battiscopa	10	6,0000	9,00	70	420,00	630,00
8,5x45/3 <sup>1/2</sup> "x18" Battiscopa	8	3,6000	6,50	69	248,40	448,50

## Caratteristiche/Features/Caracteristiques/Eigenschaften/Eigenschappen/Características



UNI EN ISO 10545/14

Classe 5 / Class 5



DIN 51130

R10  
R11 OUT2.0



DIN 51097

A+B+C



B.C.R.A. Rep. CEC/81

Asciutto > 0,40 / Bagnato > 0,40



ANSI A137.1-2012 (BOT3000)

> 0,42 Wet

Sand 45x90/18"x36" R

Gaja  
134/135







## The greatness of nature

Giant racconta la grandezza della natura e la maestosità delle foreste di castagni millenari, colossi arborei che svettano verso il cielo. L'imponenza di questi elementi naturali è evocata dal grande formato 30x240, proposta innovativa che va ad affiancare i formati 25x150 e 15x90. La superficie è caratterizzata da morbide e lunghe striature e conferisce agli ambienti un appeal elegante e prestigioso. Completa la gamma il decoro Stick, ispirato ai parquet industriali e composto da piccoli e variagati listelli.

Giant illustrates the size of nature and the majestic grandeur of thousand-year-old chestnut woods, colossal trees stretching skywards. The impressiveness of these natural elements is brought to mind by the large 30x240 size, an innovative offering which supplements the existing 25x150 and 15x90 sizes. The surface is distinguished by soft, long streaks and lends its surroundings an elegant and prestigious appeal. The range is completed by the Stick decoration, inspired by industrial parquet floors and consisting of small, multi-coloured strips.

Giant raconte la grandeur de la nature et la majesté des forêts de châtaigniers millénaires, ces arbres colossaux qui s'élèvent dans le ciel. La puissance de ces éléments naturels est évoquée par le grand format 30x240, proposition innovante qui s'ajoute aux formats 25x150 et 15x90. La surface est caractérisée par des stries souples et longues et confère aux environnements un charme fait d'élégance et de prestige. La gamme est complétée par la décoration Stick, inspirée des parquets industriels et composée de petites lattes bigarrées.

Giant erzählt von der Größe der Natur und der Pracht der tausendjährigen Kastanienwälder, Baumriesen, die in den Himmel ragen. Die Großartigkeit dieser natürlichen Elemente wird durch das große Format 30x240 hervorgerufen, ein innovativer Vorschlag, der sich zu den Formaten 25x150 und 15x90 gesellt. Die Oberfläche ist durch weiche und lange Streifen ausgezeichnet und das verleiht der Umgebung ein elegantes Aussehen. Abgerundet wird das Sortiment durch das Dekor Stick in Industrieparkett-Optik aus kleinen, unterschiedlichen Riemen.

Giant brengt de grootsheid van de natuur tot uitdrukking en de majestueuze eeuwenoude kastanjabossen, met hun kolossale bomen die tot in de hemel reiken. De grootsheid van deze natuurelementen weerspiegelt zich in het grote formaat van 30x240, een innovatief aanbod als aanvulling op de formaten 25x150 en 15x90. Het oppervlak is gekenmerkt door vloeiende, lange strepen, een wat ruimten een elegant, prestigieus uiterlijk geeft. Het gamma wordt gecompleteerd door Stick, geïnspireerd op industriële parketvloeren, bestaande uit veel uiteenlopende houten lamellen.

Giant relata la grandezza de la naturaleza y la majestuosidad de los bosques de castaños milenarios, colosos arbóreos que se elevan hacia el cielo. La imponencia de estos elementos naturales se evoca en el formato grande de 30x240 mediante una propuesta innovadora que complementa los formatos de 25x150 y 15x90. La superficie está caracterizada por estrías suaves y largas y confiere a los ambientes un aspecto elegante y prestigioso. Completa la gama la decoración Stick, inspirada en los parqués industriales con franjas pecueñas y variopintas.

9 mm

30x240/12"x96" R  
25x150/10"x60" R  
15x90/6"x36" R

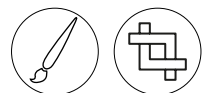

V3  
Moderate



Pith      30x240/12"x96" R      MJ71  
            25x150/10"x60" R      MJ61  
            15x90/6"x36" R        NA73



Sap      30x240/12"x96" R      MJ72  
            25x150/10"x60" R      MJ62  
            15x90/6"x36" R        NA74



Heart     30x240/12"x96" R      MJ70  
            25x150/10"x60" R      MJ60  
            15x90/6"x36" R        NA72



Bark     30x240/12"x96" R      MJ69  
            25x150/10"x60" R      MJ59  
            15x90/6"x36" R        NA71



**Dew**      **30x240/12"x96" R**      **NB63**  
              **25x150/10"x60" R**      **NB57**  
              **15x90/6"x36" R**        **NB61**



**Moss**      **30x240/12"x96" R**      **NB64**  
              **25x150/10"x60" R**      **NB58**  
              **15x90/6"x36" R**        **NB62**



Stick 75x150/30"x60" R MK46

Stick 75x150/30"x60" R



Pezzi speciali/Trim tiles/Pieces speciales/Formteile/Speciale delen/Piezas especiales



Battiscopa

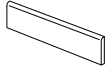

7x90/27/8"x36" R

Bark	NA16
Dew	NB55
Heart	NA17
Moss	NB56
Pith	NA18
Sap	NA19

Imballi/Packing/Emballage/Verpackungseinheiten/Verpakking/Embalajes

	pcs x box	m <sup>2</sup> / m x box	kg x box	box x pallet	m <sup>2</sup> x pallet	kg x pallet
30x240/12"x96"	1	0,7200	15,30	72	51,84	1101,60
25x150/10"x60"	3	1,1250	24,50	30	33,75	735,00
15x90/6"x36"	10	1,3500	27,70	36	48,60	997,20
75x150/30"x60" Stick	1	1,1250	24,50	25	28,13	612,50
7x90/27/8"x36" Battiscopa	6	5,4000	8,00	55	297,00	440,00

Caratteristiche/Features/Caracteristiques/Eigenschaften/Eigenshappen/Características



UNI EN ISO 10545/14

Classe 5 / Class 5



DIN 51130

R9



B.C.R.A. Rep. CEC/81

Asciutto > 0,40 / Bagnato > 0,40



ANSI A137.1-2012 (BOT3000)

> 0,42 Wet



## Urban style

Dall'osservazione di ambienti industriali e spazi metropolitani nasce una collezione che reinterpreta il cemento su grès porcellanato, materiale versatile ed eccellente per prestazioni tecniche ed estetiche. Ceramiche monocromatiche che riprendono le tonalità della materia grezza, variando dalle sfumature del grigio a nuance più calde chiare e scure, graffiate da segni piacevolmente irregolari; per ambienti di sapore minimalista e di grande impatto visivo. Superfici dal design essenziale in linea con l'ideale estetico contemporaneo, versatili ed originali, perfette per ogni tipo di espressione progettuale.

Created following meticulous monitoring of industrial areas and metropolitan spaces, Refin has created a new ceramic collection that reinterprets cement in porcelain stoneware, a versatile and excellent material in terms of technical and aesthetic performance. Monochromatic ceramics evoking the hues of raw cement, ranging from grey shades to warmer bright and dark tints, scratched by deliberately irregular marks, for minimal spaces of great visual impact. Essential, versatile and original design surfaces in keeping with contemporary aesthetic models, the perfect choice for any design expression.

L'observation d'environnements industriels et d'espaces métropolitains a donné naissance à une collection qui réinterprète le ciment sur grès cérame, un matériau versatile et excellent pour des prestations techniques et esthétiques. Des céramiques monochromatiques qui reprennent les tonalités de la matière brute, en variant des nuances du gris à des nuances plus chaudes, claires et foncées, éraflées par des signes agréablement irréguliers, pour des espaces à la saveur minimaliste et d'un grand impact visuel. Des surfaces au design essentiel en harmonie avec l'idéal esthétique contemporain, versatiles et originales, parfaites pour tous les types d'expression conceptuelle.

Der Beobachtung von Industrieumgebungen und großstädtischen Räumen entspringt eine Kollektion, die den Zement in Feinsteinzeug, einem vielseitigen Material mit ausgezeichneten technischen und ästhetischen Leistungen, neu interpretiert. Einfarbige Keramiken, die den Farbton des Rohmaterials übernehmen und von den Graunuancen bis hin zu wärmeren hellen ebenso wie dunklen Nuancen reichen, die von angenehm unregelmäßigen Kratzern durchzogen werden. Für Umgebungen in minimalistischem Stil, die einen starken optischen Eindruck hinterlassen. Oberflächen mit elementarem Design im Einklang mit dem zeitgemäßen Ästhetikideal, vielseitig und originell, perfekt für jede Art von Ausdrucksweise in der Planung.

Deze collectie vindt haar oorsprong in de observatie van industriële omgevingen en grootstedelijke gebieden en is een herinterpretatie van cement op grès porcellanato, een veelzijdig en excellent materiaal zowel qua technische als esthetische prestaties. Monochromatische keramische tegels met nuances van ruw materiaal en kleurvariaties gaande van grijs tot wärmere lichte en donkere baksteentinten, opzettelijk gekrast door onregelmatige tekens, voor een minimalistisch interieur dat in het oog springt. Oppervlakken met een essentieel design dat perfect is afgestemd op de hedendaagse esthetische idealen, veelzijdig en origineel, perfect voor alle soorten projecten.

De la observación de los ambientes industriales y espacios urbanos surge una colección que vuelve a interpretar el cemento sobre gres porcelánico, material versátil y excelente por sus prestaciones técnicas y estéticas. Cerámicas monocromáticas que retoman los tonos de la materia bruta, cambiando los matices del gris por matices claros y oscuros más cálidos, marcados por suaves signos irregulares; para ambientes de estilo minimalista y con gran impacto visual. Superficies de diseño esencial en línea con el ideal estético contemporáneo, versátiles y originales, perfectas para cualquier tipo de expresión proyectual.

✂ 9 mm

60x60/24"x24" R  
30x60/12"x24" R

✂ 9,5 mm

45x45/18"x18"





Fondi/Plain Tiles/Fonds/  
Grundfliesen/Fondsen/Fondos

V2  
Slight

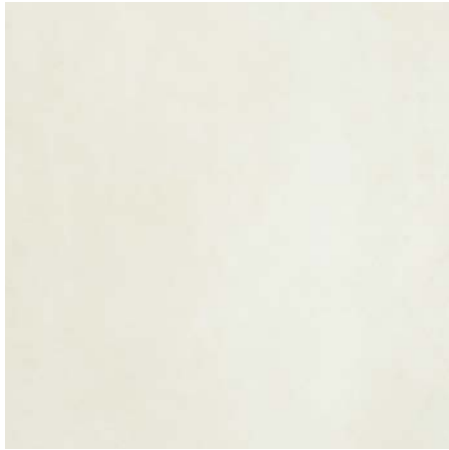

**Bianco** 60x60/24"x24" R 1898  
30x60/12"x24" R NG31  
45x45/18"x18" LA96



**Cenere** 60x60/24"x24" R 1906  
30x60/12"x24" R NG30  
45x45/18"x18" L996



**Grigio** 60x60/24"x24" R 1888  
30x60/12"x24" R NG28  
45x45/18"x18" L997



**Antracite** 60x60/24"x24" R 1903  
30x60/12"x24" R NG33  
45x45/18"x18" L998



**Corda** 60x60/24"x24" R 1901  
30x60/12"x24" R NG29  
45x45/18"x18" L995



**Beige** 60x60/24"x24" R 1900  
30x60/12"x24" R NG32  
45x45/18"x18" LA50



Terra      60x60/24"x24" R      I902  
                 30x60/12"x24" R      NG27  
                 45x45/18"x18"      LA49

Corda 60x60/24"x24" R





**Bianco Urban** 30x60/12"x24" R NG17



**Cenere Urban** 30x60/12"x24" R NG16



**Grigio Urban** 30x60/12"x24" R NG14



**Antracite Urban** 30x60/12"x24" R NG19



**Corda Urban** 30x60/12"x24" R NG15



**Beige Urban** 30x60/12"x24" R NG18

8 soggetti diversi formato  
30x60 (miscelazione  
casuale)/  
8 assorted motifs  
30x60 size (random mix)/  
8 sujets differents  
format 30x60  
(melange aleatoire)/  
8 verschiedene Motive  
Format 30x60  
(Zufallsmischung)/  
8 verschillende  
ontwerpen in 30x60  
(willekeurig gemengd)/  
8 motivos diferentes  
formato 30x60 (mezcla  
aleatoria)



Composizione di 16 pezzi  
formato 60x60/  
Composition containing  
16 pieces 60x60 size/  
Composition 16 pièces  
format 60x60/  
Komposition aus 16  
Teilen Format 60x60/  
Compositie van 16 tegels  
van 60x60/Composición  
de 16 piezas formato  
60x60.



Urban 60x60/24"x24" R L241  
Cool



Urban 60x60/24"x24" R L254  
Warm



V2  
Slight

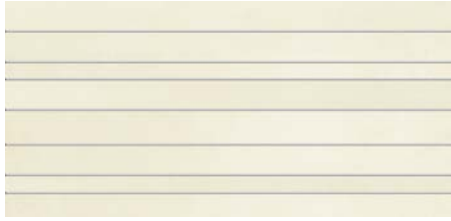

**Bianco Muretto** 30x60/12"x24" R LA74



**Cenere Muretto** 30x60/12"x24" R LA75



**Grigio Muretto** 30x60/12"x24" R LA77

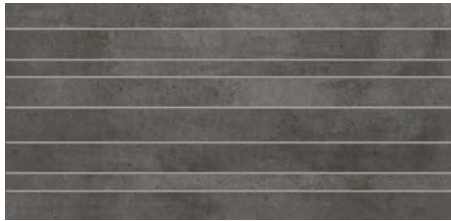

**Antracite Muretto** 30x60/12"x24" R LA72

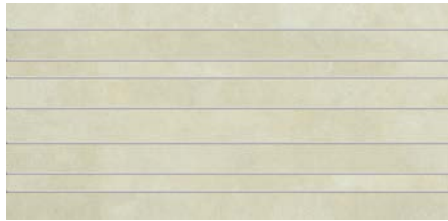

**Corda Muretto** 30x60/12"x24" R LA76



**Beige Muretto** 30x60/12"x24" R LA73



**Terra Muretto** 30x60/12"x24" R LA78

Pezzi speciali/Trim tiles/Pieces speciales/Formteile/Speziale delen/Piezas especiales



Battiscopa

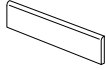

10x60/4"x24" R

Antracite	I932
Beige	I928
Bianco	I927
Cenere	I930
Corda	I929
Grigio	I931
Terra	I933

Imballi/Packing/Emballage/Verpackungseinheiten/Verpakking/Embalajes

	pcs x box	m <sup>2</sup> / m x box	kg x box	box x pallet	m <sup>2</sup> x pallet	kg x pallet
60x60/24"x24"	3	1,0800	21,35	40	43,20	854,00
30x60/12"x24"	7	1,2600	25,00	40	50,40	1000,00
45x45/18"x18"	5	1,0125	20,60	33	33,41	679,80
60x60/24"x24" Urban (Set 16pz)	1	5,7600	114,00	1	5,76	114,00
30x60/12"x24" Urban	7	1,2600	25,00	40	50,40	1000,00
30x60/12"x24" Muretto	4	0,7200	13,80	21	15,12	289,80
10x60/4"x24" Battiscopa	10	6,0000	11,50	60	360,00	690,00

Caratteristiche/Features/Caracteristiques/Eigenschaften/Eigenschappen/Características



UNI EN ISO 10545/14

Classe 5 / Class 5



DIN 51130

R10



DIN 51097

A+B



BS 7976-2:2002  
(CEN/TS 16165, Annex C)  
Pendulum Friction Test

≥ 36 Wet



B.C.R.A. Rep. CEC/81

Asciutto > 0,40 / Bagnato > 0,40



ANSI A137.1-2012 (BOT3000)

> 0,42 Wet

Fango 75x150/30"x60" Soft R



## Breezy charm

La trama granulosa della pietra caratterizza Grecale: il vento fresco del Mediterraneo che soffia da nord-est, artefice di sedimentazioni ed erosioni millenarie, diventa l'ispirazione per una texture moscia da puntinature chiaroscure, che si amalgamano creando superfici dall'impatto cromatico omogeneo. Adatta per ambienti moderni e minimal, la collezione è disponibile in molti formati rettangolari o quadrati. Le sei nuance naturali (Ghiaccio – bianco, Acciaio – grigio chiaro, Grafite – grigio scuro, Fango, Sabbia e Crema) si abbinano al decoro Kite, caratterizzato da un pattern geometrico molto sottile ma definito. Completano la serie il mosaico Penta, dalla forma irregolare, e il muretto 3D che alterna diverse altezze, parti lucide e altre strutturate.

Grecale is distinguished by a fine texture of stone. The cool wind of the Mediterranean that blows from the northeast, cause of sedimentation and erosion over the course of millennia, is the inspiration for a texture dotted by light and dark spots that blend together creating surfaces with a uniform colour. Suitable for modern and minimalist environments, the collection is available in many rectangular or square sizes. The six natural shades (Ghiaccio - ice, Acciaio - steel, Grafite - graphite, Fango - graybrown, Sabbia - sand and Crema - beige) combine with the Kite decoration, distinguished by a very subtle but defined geometric pattern. The series is completed by the Penta mosaic with its irregular shapes, and the 3D wall tile that alternates different heights and has shiny and textured parts.

La trame fine de la pierre caractérise Grecale: le vent frais de nord-est qui souffle sur la Méditerranée, responsable de la sédimentation et de l'érosion millénaire, inspire la texture mouvementée d'un revêtement riche en clairs-obscur en offrant des surfaces à l'impact chromatique très homogène. Adaptée pour des espaces modernes et minimalistes, la collection est disponible dans plusieurs formats carrés ou rectangulaires. Les six tonalités naturelles (Ghiaccio – blanc, Acciaio – gris clair, Grafite – gris foncé, Fango – argile, Sabbia – sable et Crema - beige) sont associées au décor Kite, caractérisé par un motif géométrique ultra fin mais bien défini. La série est complétée par la mosaïque Penta, de forme irrégulière, et le muret 3D qui alterne différentes hauteurs, des parties brillantes et d'autres structurées.

Grecale ist wie ein Naturstein fein strukturiert: der kühle, von Nordosten wehende Mittelmeerwind formt im Laufe der Jahrtausende Ablagerungen und Erosionen und wird zur Inspirationsquelle für eine besondere Textur, in der sich helle und dunkle Stellen vermischen und farblich gleichmäßig wirkende Oberflächen erzeugen. Die für ein modernes und minimalistisches Ambiente ideale Kollektion ist in vielen rechteckigen oder quadratischen Formaten erhältlich. Die sechs natürlichen Nuancen (Ghiaccio – Hell, Acciaio – Hellgrau, Grafite – Dunkelgrau, Fango – Schlamm, Sabbia – Sand und Crema - Beige) können mit der Kite-Dekoration kombiniert werden, zeichnet sich durch ein sehr feines, aber klar definiertes geometrisches Muster aufweist. Komplettiert wird die Serie durch das unregelmäßig geformte Mosaik Penta und durch Muretto 3D, in dem sich unterschiedliche Höhen, glänzende und strukturierte Teile abwechseln.

Grecale wordt gekenmerkt door de fijne structuur van steen: de koele wind van de Middellandse Zee, die vanuit het noordoosten blaast en de schepper is van sedimentatie en duizendjarige erosie, wordt de inspiratie voor een textuur met donkere en lichte punten die zich mengen en oppervlakken met een gelijkmatige kleur creëren. De collectie die geschikt is voor moderne en minimalistische ruimtes is verkrijgbaar in veel rechthoekige of vierkante formaten. De zes natuurlijke kleuren (Ghiaccio – wit, Acciaio – lichtgrijs, Grafite – donkergrijs, Fango – modder, Sabbia – sand en Crema -beige) combineren met de Kite decoratietegel, een heel subtiel maar duidelijk geometrisch patroon heeft. Het mozaiek Penta maakt de serie af. Het heeft een onregelmatige vorm en de 3D muretto tegels (tegelstroken), wisselen verschillende hoogtes, glanzende delen en andere, gestructureerde tegels met elkaar af.

La trama fina de la pedra caracteriza Grecale: el viento fresco del Mediterráneo que sopla desde noroeste, artifice de sedimentaciones y erosiones milenarias se convierte en la inspiración de una textura movida por punteados claros-oscuros que al mezclarse crean superficies de impacto cromático homogéneo. Ideal para ambientes modernos y minimalistas, la colección está disponible en muchos formatos rectangulares o cuadrados. Los seis matices naturales (Ghiaccio - hielo, Acciaio - acero, Grafite - grafito, Fango - fango, Sabbia - arena y Crema - beige) se combinan con la decoración de Kite, caracterizada por un pattern geométrico muy suave pero definido. Completan la serie el mosaico Penta, de forma irregular, y el murete 3D que alterna diferentes alturas, partes brillantes y otras abujardadas.

✂ 9 mm

75x150/30"x60" Soft R  
75x75/30"x30" Soft R  
60x60/24"x24" R  
60x60/24"x24" Soft R  
30x60/12"x24" R  
30x60/12"x24" Soft R

Gres porcellanato  
Porcelain stoneware  
Grès cérame fin vitrifié  
Feinsteinzeug  
Porseleingres  
Gres porcelánico





V2  
Slight

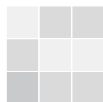

**Ghiaccio** 75x150/30"x60" Soft R **MN55**  
75x75/30"x30" Soft R **MQ11**  
60x60/24"x24" R **MQ71**  
60x60/24"x24" Soft R **MQ76**  
30x60/12"x24" R **NG10**  
30x60/12"x24" Soft R **NG04**



**Acciaio** 75x150/30"x60" Soft R **MN53**  
75x75/30"x30" Soft R **MQ09**  
60x60/24"x24" R **MQ70**  
60x60/24"x24" Soft R **MQ75**  
30x60/12"x24" R **NG13**  
30x60/12"x24" Soft R **NG07**



**Grafite** 75x150/30"x60" Soft R **MN58**  
75x75/30"x30" Soft R **MQ10**  
60x60/24"x24" R **MQ72**  
60x60/24"x24" Soft R **MQ77**  
30x60/12"x24" R **NG09**  
30x60/12"x24" Soft R **NG03**



**Sabbia** 75x150/30"x60" Soft R **MN62**  
75x75/30"x30" Soft R **MQ13**  
60x60/24"x24" R **MQ73**  
60x60/24"x24" Soft R **MQ79**  
30x60/12"x24" R **NG08**  
30x60/12"x24" Soft R **NG02**



**Crema** 75x150/30"x60" Soft R **MU43**  
75x75/30"x30" Soft R **MU45**  
60x60/24"x24" R **MU46**  
60x60/24"x24" Soft R **MU47**  
30x60/12"x24" R **NG12**  
30x60/12"x24" Soft R **NG06**



**Fango** 75x150/30"x60" Soft R **MN60**  
75x75/30"x30" Soft R **MQ12**  
60x60/24"x24" R **MQ74**  
60x60/24"x24" Soft R **MQ78**  
30x60/12"x24" R **NG11**  
30x60/12"x24" Soft R **NG05**

Crema 75x150/30"x60" Soft R

**Grecale**  
**152/153**



Kite Ghiaccio 75x150/30"x60" R MQ97

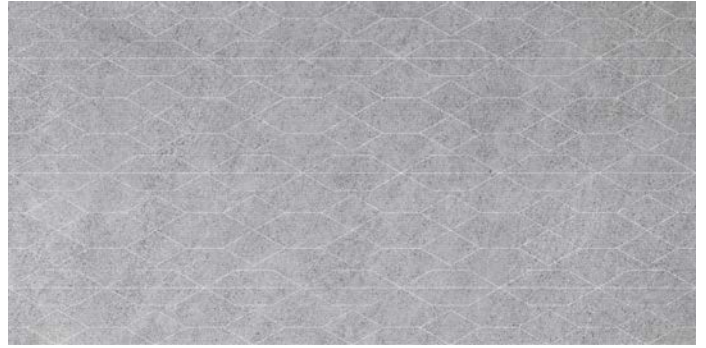

Kite Acciaio 75x150/30"x60" R MQ96

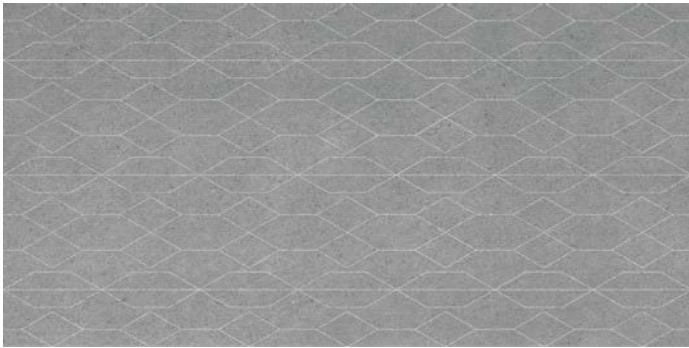

Kite Grafite 75x150/30"x60" R MQ98



Kite Sabbia 75x150/30"x60" R MR00



Kite Crema 75x150/30"x60" R MU56



Kite Fango 75x150/30"x60" R MQ99

Acciaio 75x75/30"x30" Soft R — Kite Acciaio 75x150/30"x60" R





V2  
Slight

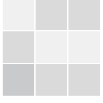

**Ghiaccio** 31,5x31,5/12<sup>3/8</sup>"x12<sup>3/8</sup>" Soft R **MP42**  
Mosaico Penta Soft



**Acciaio** 31,5x31,5/12<sup>3/8</sup>"x12<sup>3/8</sup>" Soft R **MP40**  
Mosaico Penta Soft



**Grafite** 31,5x31,5/12<sup>3/8</sup>"x12<sup>3/8</sup>" Soft R **MP43**  
Mosaico Penta Soft



**Sabbia** 31,5x31,5/12<sup>3/8</sup>"x12<sup>3/8</sup>" Soft R **MP44**  
Mosaico Penta Soft



**Crema** 31,5x31,5/12<sup>3/8</sup>"x12<sup>3/8</sup>" Soft R **MU29**  
Mosaico Penta Soft



**Fango** 31,5x31,5/12<sup>3/8</sup>"x12<sup>3/8</sup>" Soft R **MP41**  
Mosaico Penta Soft



**Ghiaccio** 31,5x45/12<sup>3/8</sup>"x18" R **MP84**  
**Muretto 3D**



**Acciaio** 31,5x45/12<sup>3/8</sup>"x18" R **MP83**  
**Muretto 3D**

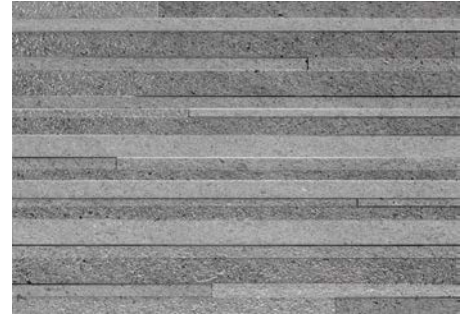

**Grafite** 31,5x45/12<sup>3/8</sup>"x18" R **MP85**  
**Muretto 3D**



**Sabbia** 31,5x45/12<sup>3/8</sup>"x18" R **MP87**  
**Muretto 3D**

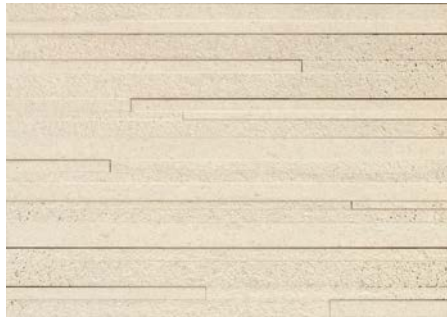

**Crema** 31,5x45/12<sup>3/8</sup>"x18" R **MU28**  
**Muretto 3D**



**Fango** 31,5x45/12<sup>3/8</sup>"x18" R **MP86**  
**Muretto 3D**

**Ghiaccio Muretto 3D 31,5x45/12<sup>3/8</sup>"x18" R**



## Pezzi speciali/Trim tiles/Pieces speciales/Formteile/Speciale delen/Piezas especiales

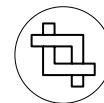

### Battiscopa

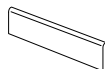

#### 7x75/2<sup>7/8</sup>"x30" R

Acciaio	<b>MQ37</b>
Crema	<b>MU30</b>
Fango	<b>MQ40</b>
Ghiaccio	<b>MQ38</b>
Grafite	<b>MQ39</b>
Sabbia	<b>MQ41</b>

#### 7x60/2<sup>7/8</sup>"x24" R

Acciaio	<b>MQ42</b>
Crema	<b>MU31</b>
Fango	<b>MQ45</b>
Ghiaccio	<b>MQ43</b>
Grafite	<b>MQ44</b>
Sabbia	<b>MQ46</b>

## Imballi/Packing/Emballage/Verpackungseinheiten/Verpakking/Embalajes

	pcs x box	m <sup>2</sup> / m x box	kg x box	box x pallet	m <sup>2</sup> x pallet	kg x pallet
75x150/30"x60"	1	1,1250	24,50	25	28,13	612,50
75x75/30"x30"	2	1,1250	24,00	42	47,25	1008,00
60x60/24"x24"	3	1,0800	21,35	40	43,20	854,00
30x60/12"x24"	7	1,2600	25,00	40	50,40	1000,00
31,5x45/12 <sup>3/8</sup> "x18" Muretto 3D	6	0,8505	21,00	52	44,23	1092,00
31,5x31,5/12 <sup>3/8</sup> "x12 <sup>3/8</sup> " Mosaico Penta	6	0,5954	13,00	42	25,01	546,00
7x75/2 <sup>7/8</sup> "x33" Battiscopa	10	7,5000	11,00	54	405,00	594,00
7x60/2 <sup>7/8</sup> "x24" Battiscopa	10	6,0000	9,00	70	420,00	630,00

Grecale MATT and SOFT finishes are recommended for interior floors, walls, and exterior walls in both residential and commercial applications. Grecale is not recommended for exterior horizontal surfaces or exterior paving, and it is not recommended for ramps application. Grecale SOFT finish is not recommended for interior floors in entrance areas if joined to outdoor in commercial applications. Grecale LAPPATO is recommended for interior walls, and exterior walls in both residential and commercial applications. Grecale LAPPATO finish is not recommended for floors.

## SOFT Caratteristiche/Features/Caracteristiques/Eigenschaften/Eigenshappen/Características



UNI EN ISO 10545/14

Classe 5 / Class 5



B.C.R.A. Rep. CEC/81

Asciutto > 0,40 / Bagnato > 0,40



ANSI A137.1-2012 (BOT3000)

> 0,42 Wet

## MATT Caratteristiche/Features/Caracteristiques/Eigenschaften/Eigenshappen/Características



UNI EN ISO 10545/14

Classe 5 / Class 5



DIN 51130

R10



BS 7976-2:2002  
(CEN/TS 16165, Annex C)  
Pendulum Friction Test

≥ 36 Wet



B.C.R.A. Rep. CEC/81

Asciutto > 0,40 / Bagnato > 0,40



ANSI A137.1-2012 (BOT3000)

> 0,42 Wet

Grafite 75x150/30"x60" Soft R — Acciaio Mosaico Penta Soft 31,5x31,5/12<sup>3/8</sup>"x12<sup>3/8</sup>" Soft R







# Kasai

# 160/161

## Oriental masterpiece

Kasai, "fuoco", si ispira allo Shou Sugi Ban o Yakisugi, la tradizionale tecnica artigianale giapponese che lavora il legno tramite bruciatura, carbonizzando solitamente quello di cedro al fine di proteggerlo e conservarlo. La collezione omaggia la cultura progettuale nipponica esprimendo sul grès porcellanato le stesse caratteristiche vive e tattili ottenute sulle doghe: raffinata ed elegante, celebra l'incontro tra mondi diversi, interfacciando tradizione e innovazione. Kasai è disponibile nel formato 25x150 nelle tonalità Carta, Fumo o Notte.

Kasai, "fire", is inspired by Shou Sugi Ban or Yakisugi, the traditional Japanese artisanal technique that works through burning wood, usually cedar, carbonising it in order to protect and conserve it. The collection pays homage to Japanese design culture, expressing in porcelain stoneware the same visual and tactile characteristics as achieved on the slats: refined and elegant, celebrating the convergence of different worlds, bringing together tradition and innovation. Kasai is available in the 25x150 size in the shades of Carta (Paper), Fumo (Smoke) and Notte (Night).

Kasai, "feu", s'inspire du Shou Sugi Ban ou Yakisugi, une technique artisanale traditionnelle du Japon, où le bois est travaillé par brûlure, à savoir en carbonisant principalement le bois de cèdre pour le protéger et le conserver. La collection rend hommage à la culture japonaise en traduisant sur le grès cérame, les mêmes caractéristiques visuelles et tactiles obtenues sur les lames : raffinée et élégante, cette collection célèbre la rencontre entre différents mondes, en alliant tradition et innovation. Kasai est disponible au format 25x150 dans les tonalités Carta (Papier), Fumo (Fumée) ou Notte (Nuit).

Kasai, „Feuer“, ist am Shou Sugi Ban bzw. Yakisugi inspiriert, der traditionellen japanischen Handwerks-technik, bei der das Holz durch Brennen bearbeitet wird. Dabei wird meist Zedernholz verkohlt, um es auf Dauer zu schützen. Die Kollektion ist eine Hommage an die nipponische Projektkultur. Sie reproduziert die gleichen optischen und taktilen Merkmale des so behandelten Holzes auf Feinsteinzeug: Die Wirkung ist edel und elegant, eine Begegnung zwischen unterschiedlichen Welten, eine Verknüpfung von Tradition und Innovation. Kasai ist im einzigen Format 25x150 in den Farbtönen Carta (Papier), Fumo (Rauch) oder Notte (Nacht) lieferbar.

Kasai, "vuur" is geïnspireerd op Shou Sugi Ban of Yakisugi, de traditionele, ambachtelijke, Japanse techniek om het hout te bewerken door middel van verbranding en gewoonlijk bij cederhout een verkoelde laag te creëren om het te beschermen en het in goede staat te houden. De collectie betuigt eerbetoon aan de Japanse ontwerpcultuur door het grès porcellanato er hetzelfde uit te laten zien en aan te laten voelen als de latten: het geraffineerde en stijlvolle resultaat viert de ontmoeting tussen verschillende werelden en koppelt hierbij traditie en innovatie. Kasai is verkrijgbaar in een formaat van 25x150 en in de kleuren Carta (Papier), Fumo (Roken) of Notte (Nacht).

Kasai, "fuego", se inspira en el Shou Sugi Ban o Yakisugi, la técnica tradicional de artesanía japonesa que consiste en quemar la madera, por lo general la de cedro para protegerla y conservarla. La colección rinde homenaje a la cultura del diseño japonés expresando en el grés porcelánico las mismas características visuales y táctiles obtenidas en las tablas: refinada y elegante, celebra el encuentro entre mundos diferentes, poniendo en contacto tradición e innovación. Kasai está disponible en el formato 25x150 con tonalidad Paper (Papel), Fumo (Humo) o Notte (Noche).

9 mm

25x150/10"x60" R



Gres porcellanato  
Porcelain stoneware  
Grès cérame fin vitrifié  
Feinsteinzeug  
Porseleingres  
Gres porcelánico

V3  
Moderate



Carta 25x150/10"x60" R MN81



Fumo 25x150/10"x60" R MN82



Notte 25x150/10"x60" R MN83

Fumo 25x150/10"x60" R

Kasai  
162/163





Carta 25x150/10"x60" R MR01  
Kanji



Fumo 25x150/10"x60" R MR02  
Kanji



Notte 25x150/10"x60" R MR07  
Kanji

Notte 25x150/10"x60" R — Notte Kanji 25x150/10"x60" R

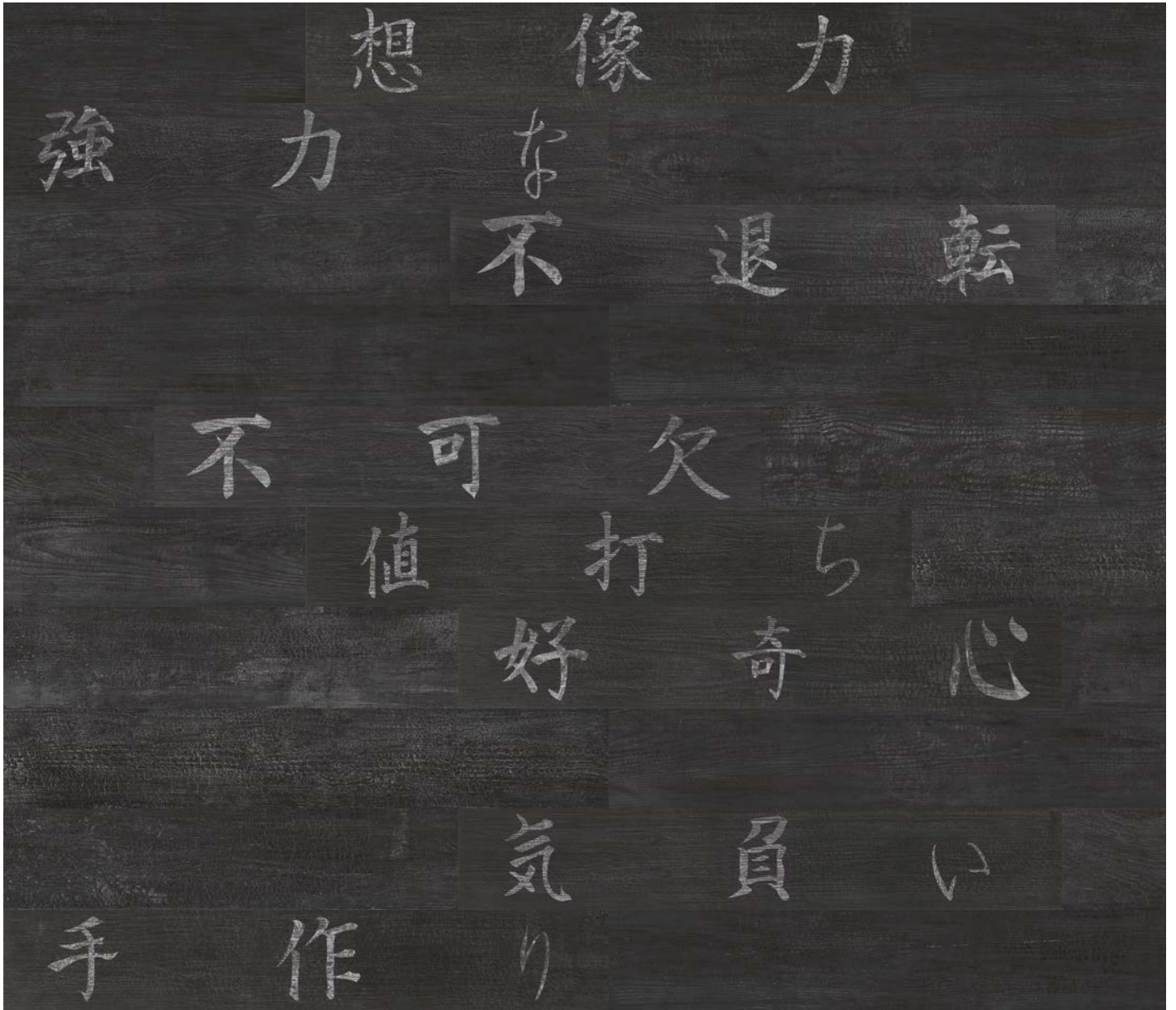

不可欠 indispensable  
不退転 determination  
気負い fighting spirit  
思い出 memories  
何時も always  
手作り handmade

値打ち value  
強力な powerful  
想像力 imagination  
夢見る dreamed  
好奇心 curiosity

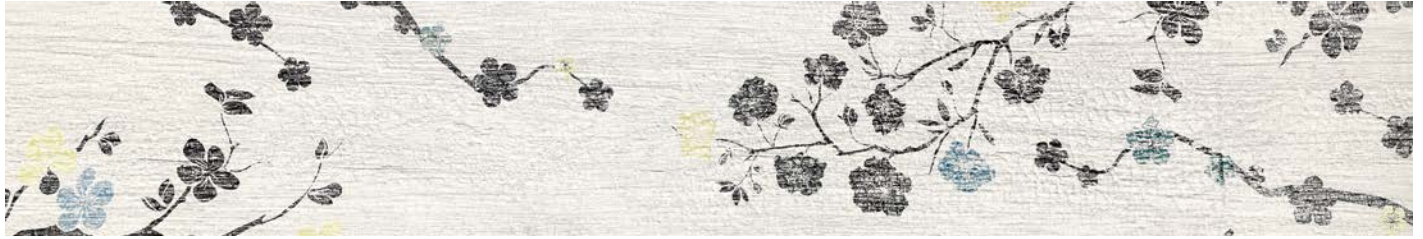

**Carta** 25x150/10"x60" R **MR76**  
**Sakura**

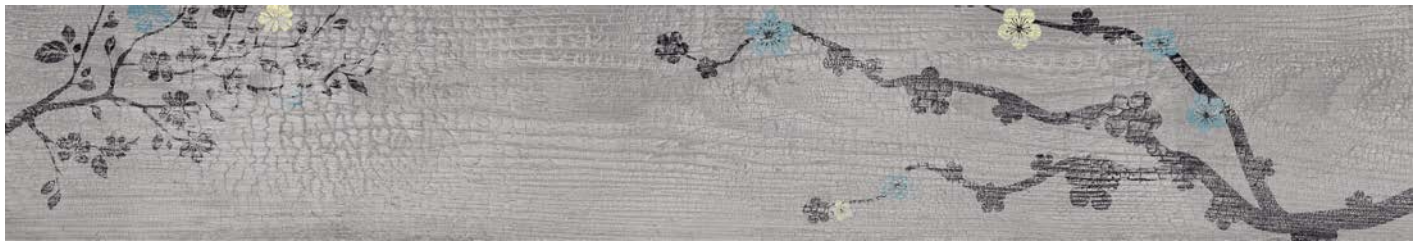

**Fumo** 25x150/10"x60" R **MR77**  
**Sakura**



**Notte** 25x150/10"x60" R **MR78**  
**Sakura**



**Carta** 25x150/10"x60" R **MR82**  
**Take**



**Fumo** 25x150/10"x60" R **MR83**  
**Take**



**Notte** 25x150/10"x60" R **MR84**  
**Take**

12 Soggetti diversi formato 25x150 (miscelazione casuale)/  
12 Assorted motifs 25x150 size (random mix)/  
12 Sujets differents format 25x150 (melange aleatoire)/  
12 Verschiedene Motive Format 25x150 (Zufallsmischung)/  
12 Verschillende ontwerpen in 25x150 (willekeurig gemengd)/  
12 Motivos diferentes formato 25x150 (mezcla aleatoria)





**Carta** 25x150/10"x60" R **MR73**  
**Koi**



**Fumo** 25x150/10"x60" R **MR74**  
**Koi**



**Notte** 25x150/10"x60" R **MR75**  
**Koi**

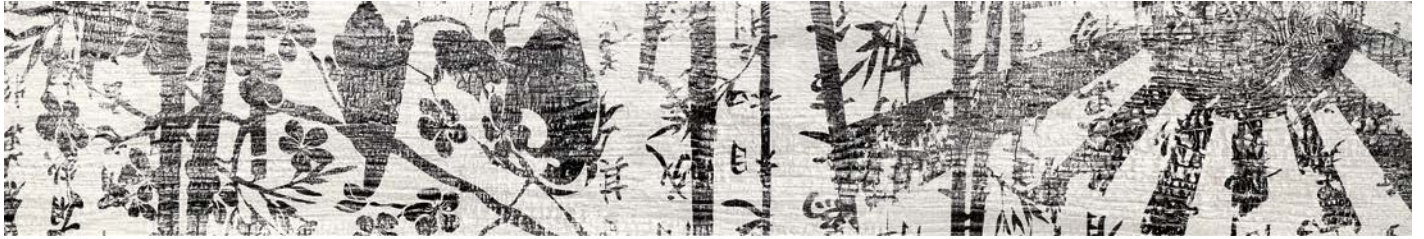

Carta 25x150/10"x60" R MR79  
Samurai



Fumo 25x150/10"x60" R MR80  
Samurai



Notte 25x150/10"x60" R MR81  
Samurai

24 Soggetti diversi formato 25x150 (miscelazione casuale)/  
24 Assorted motifs 25x150 size (random mix)/  
24 Sujets differents format 25x150 (melange aleatoire)/  
24 Verschiedene Motive Format 25x150 (Zufallsmischung)/  
24 Verschillende ontwerpen in 25x150 (willekeurig gemengd)/  
24 Motivos diferentes formato 25x150 (mezcla aleatoria)

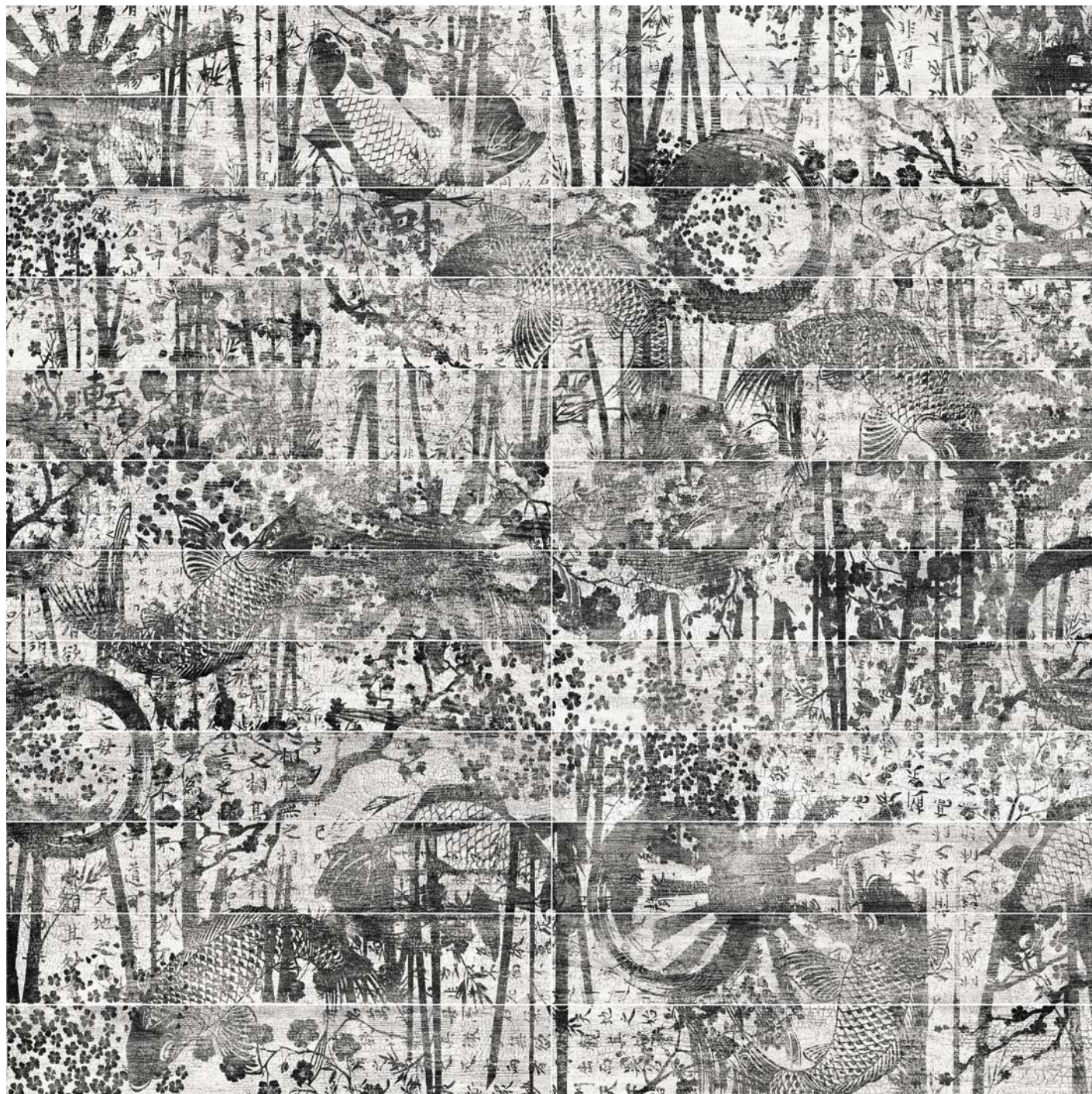

**Carta Samurai** 25x150/10"x60" R Set 24 pz **MT01**  
**Fumo Samurai** 25x150/10"x60" R Set 24 pz **MT02**  
**Noite Samurai** 25x150/10"x60" R Set 24 pz **MT03**

Composizione di 24 pezzi formato 25x150 /  
Composition containing 24 pieces 25x150 size /  
Composition 24 pièces format 25x150 /  
Komposition aus 24 Teilen Format 25x150 /  
Compositie van 24 tegels van 25x150 /  
Composición de 24 piezas formato 25x150.

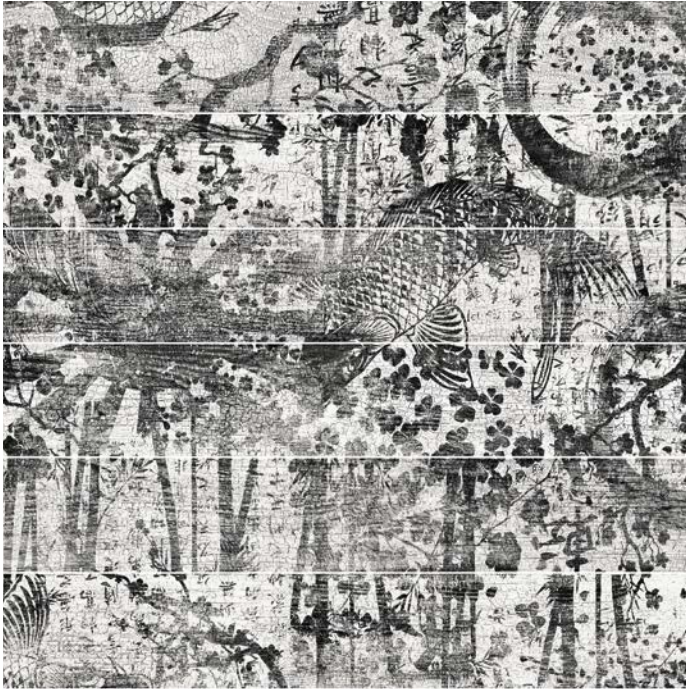

Carta 25x150/10"x60" R Set 6 pz MT92  
Samurai

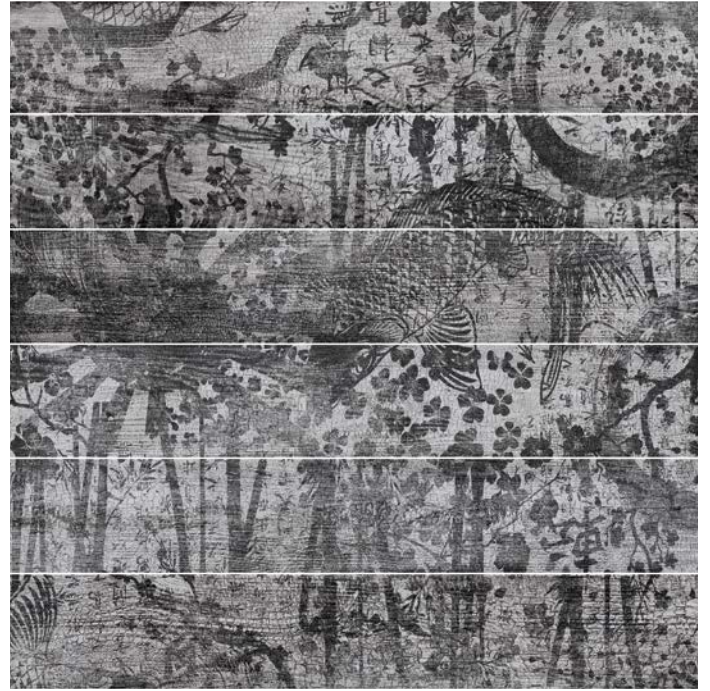

Fumo 25x150/10"x60" R Set 6 pz MT93  
Samurai

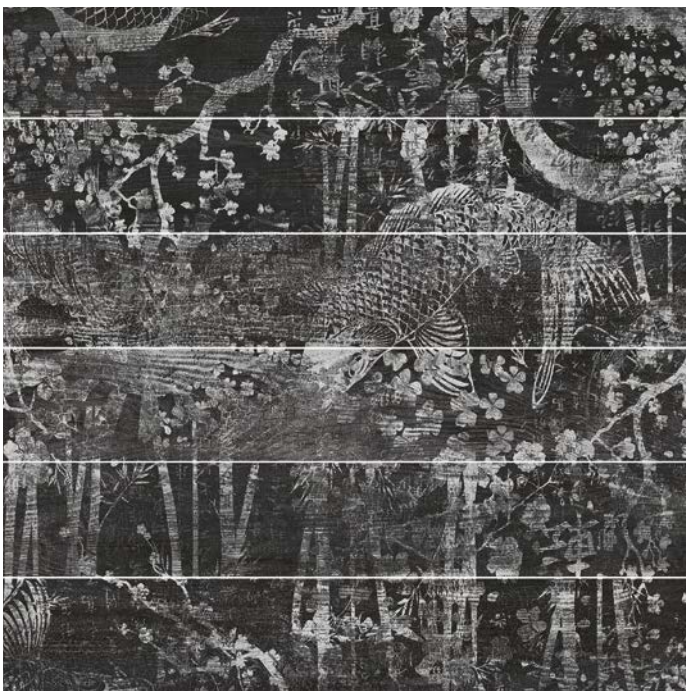

Notte 25x150/10"x60" R Set 6 pz MT94  
Samurai

Composizione di 6 pezzi formato 25x150 /  
Composition containing 6 pieces 25x150 size /  
Composition 6 pièces format 25x150 /  
Komposition aus 6 Teilen Format 25x150 /  
Compositie van 6 tegels van 25x150 /  
Composición de 6 piezas formato 25x150.



**Carta** 25x150/10"x60" R **MU90**  
**Kintsugi**



**Fumo** 25x150/10"x60" R **MU91**  
**Kintsugi**



**Notte** 25x150/10"x60" R **MU92**  
**Kintsugi**



**Carta** 25x150/10"x60" R Set 3 pz **MU95**  
**Kintsugi**

**Fumo** 25x150/10"x60" R Set 3 pz **MU96**  
**Kintsugi**

**Notte** 25x150/10"x60" R Set 3 pz **MU97**  
**Kintsugi**

Composizione di 3 pezzi formato 25x150/  
Composition containing 3 pieces 25x150 size/  
Composition 3 pieces format 25x150/  
Komposition aus 3 Teilen Format 25x150/  
Compositie van 3 tegels van 25x150/  
Composición de 3 piezas formato 25x150.

## Imballi/Packing/Emballage/Verpackungseinheiten/Verpakking/Embalajes

	pcs x box	m <sup>2</sup> / m x box	kg x box	box x pallet	m <sup>2</sup> x pallet	kg x pallet
<b>25x150/10"x60"</b>	3	1,1250	24,00	30	33,75	720,00
<b>25x150/10"x60" Set Kintsuji (set 3 pcs)</b>	1	1,1250	24,00	30	33,75	720,00
<b>25x150/10"x60" Set Samurai (set 6 pcs)</b>	1	2,2500	48,00	15	33,75	720,00
<b>25x150/10"x60" Set Samurai (set 24 pcs)</b>	1	9,0000	192,00	1	9,00	192,00

Notte 25x150/10"x60" R — Notte Kintsuji 25x150/10"x60" R Set 3 Pz

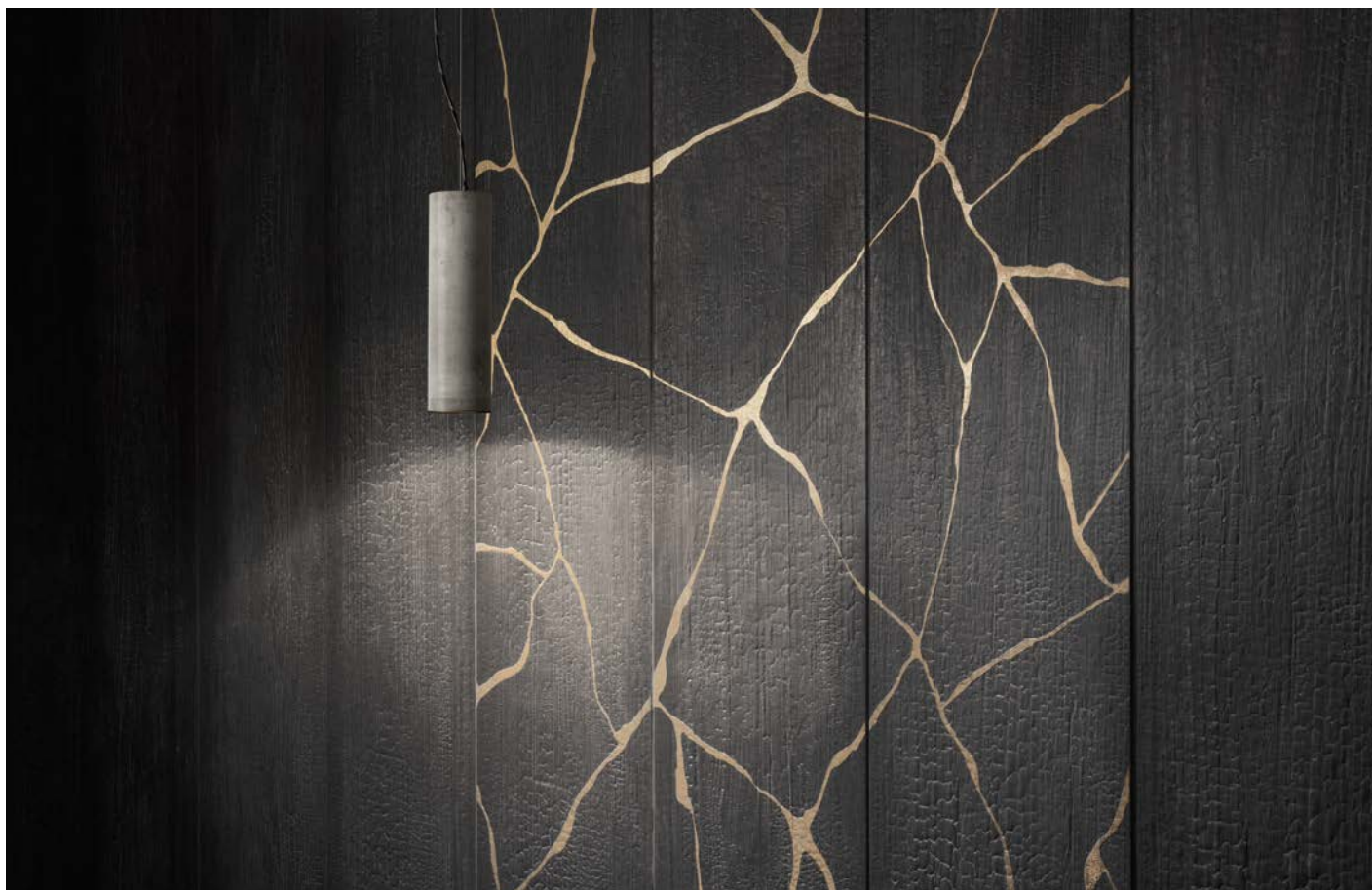

## Caratteristiche/Features/Caracteristiques/Eigenschaften/Eigenschappen/Características



UNI EN ISO 10545/14

Classe 5 / Class 5



DIN 51130

R10



BS 7976-2:2002  
(CEN/TS 16165, Annex C)  
Pendulum Friction Test

≥ 36 Wet



B.C.R.A. Rep. CEC/81

Asciutto > 0,40 / Bagnato > 0,40



ANSI A137.1-2012 (BOT3000)

> 0,42 Wet

Notte 25x150/10"x60" R







## Warm appeal of wood

Le calde sembianze del legno si coniugano con la praticità e resistenza del grès porcellanato nella collezione Larix, ispirata all'essenza di larice, ampiamente utilizzata nelle costruzioni della tradizione alpina. Larix è frutto di un'accurata ricerca sulle peculiarità del materiale naturale, e lo rievoca traducendone su ceramica, a livello sia grafico che strutturale, i dettagli cromatici e superficiali originari e i segni impressi dal tempo e dall'esposizione agli agenti atmosferici.

The warm appeal of wood combines with the functionality and resistance of porcelain stoneware in the Larix collection, inspired by larch wood and widely used in traditional alpine architecture. Larix is the result of intensive research on the features of this natural material that is reinterpreted on ceramics, reproducing its graphics and texture, its chromatic and surface details and the marks caused by the passage of time and by adverse weather.

Dans la collection Larix, la chaleur qui se dégage de l'aspect bois s'associe parfaitement au caractère pratique et à la résistance du grès cérame. La collection s'inspire en effet de l'essence de mélèze, un bois largement utilisé dans les constructions traditionnelles alpines. Larix est le fruit d'une longue étude des caractéristiques du matériau naturel et propose de le représenter sur céramique dans son graphisme et sa structure sans négliger les motifs chromatiques et superficiels particuliers, notamment les signes du temps et de l'exposition aux agents atmosphériques, qui confèrent tout son charme à la matière.

Das warme Aussehen von Holz wird bei der Kollektion Larix, die am in der traditionellen Bauweise der Alpen viel verwendeten Lärchenholz inspiriert ist, mit der Zweckmäßigkeit und Beständigkeit des Feinsteinzeugs kombiniert. Larix ist das Ergebnis einer eingehenden Forschung bezüglich der Besonderheiten dieses natürlichen Materials und möchte darauf anspielen, indem die ursprünglichen farblichen Details und Oberflächenmerkmale sowie die von der Zeit und den Witterungseinflüssen hinterlassenen Spuren sowohl grafisch, als auch strukturell auf die Keramik übertragen werden.

Warme aanblik van hout gecombineerd met de praktische voordelen en bestendigheid van grès porcellanato in de collectie LARIX, geïnspireerd op de lariks houtessentie, veelvuldig gebruikt in woningen in de traditionele Alpenstijl. Larix is het resultaat van een nauwgezette zoektocht naar de kenmerkende eigenschappen van natuurlijke materialen. Zowel op grafisch als structureel vlak worden chromatische details en oorspronkelijke oppervlaktestructuren vertaald naar keramische producten, waarbij ook de veroudering met de tijd en blootstelling aan weer en wind wordt gereproduceerd.

Las cálidas semejanzas a la madera se conjugan con la practicidad y resistencia del grès porcelánico en la colección Larix, inspirada en la esencia del alerce ampliamente utilizado en las construcciones de la tradición alpina. Larix es el fruto de un minucioso estudio de las peculiaridades del material natural y lo evoca de nuevo traduciendo en la cerámica, en lo que a gráfica y estructura se refiere, los originales detalles cromáticos y superficiales y las huellas dejadas por el tiempo y la exposición a los agentes atmosféricos.

✂ 9 mm

25x150/10"x60" R  
15x75/6"x30" R

✂ 20 mm OUT2.0

40x120/16"x48" R  
60x60/24"x24" R

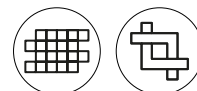

V3  
Moderate



**Natural**    25x150/10"x60" R    LE13  
                  15x75/6"x30" R        LF71  
                  40x120/16"x48" R OUT2.0    MI58  
                  60x60/24"x24" R OUT2.0    LQ02



**Fresh**        25x150/10"x60" R    LE14  
                  15x75/6"x30" R        LF73



**Sun**            25x150/10"x60" R    LE12  
                  15x75/6"x30" R        LF72  
                  40x120/16"x48" R OUT2.0    MI59  
                  60x60/24"x24" R OUT2.0    LQ04



**Shade**        25x150/10"x60" R    LE11  
                  15x75/6"x30" R        LF74  
                  60x60/24"x24" R OUT2.0    LQ03

Fresh 15x75/6"x30" R





V3  
Moderate



Natural Muretto 25x75/10"x30" R LF52



Fresh Muretto 25x75/10"x30" R LF55



Sun Muretto 25x75/10"x30" R LF53



Shade Muretto 25x75/10"x30" R LF54

Fresh Muretto Listello 25x75/10"x30" R — Shade 25x150/10"x60" R — Sun 25x150/10"x60" R



Pezzi speciali/Trim tiles/Pieces speciales/Formteile/Speciale delen/Piezas especiales



Battiscopa

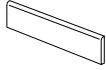

7x75/2<sup>7/8</sup>"x30" R

Fresh	LF99
Natural	LF96
Shade	LF98
Sun	LF97

Imballi/Packing/Emballage/Verpackungseinheiten/Verpakking/Embalajes

	pcs x box	m <sup>2</sup> / m x box	kg x box	box x pallet	m <sup>2</sup> x pallet	kg x pallet
25x150/10"x60"	3	1,1250	24,00	30	33,75	720,00
15x75/6"x30"	7	0,7875	17,50	48	37,80	840,00
40x120/16"x48" <b>OUT2.0</b>	2	0,9600	41,50	24	23,04	996,00
60x60/24"x24" <b>OUT2.0</b>	2	0,7200	32,40	30	21,60	972,00
25x75/10"x30" Muretto Listello	4	0,7500	16,00	24	18,00	384,00
7x75/2 <sup>7/8</sup> "x30" Battiscopa	10	7,5000	11,00	54	405,00	594,00

Caratteristiche/Features/Caracteristiques/Eigenschaften/Eigenschappen/Características



UNI EN ISO 10545/14

Classe 5 / Class 5



DIN 51130

R10  
R11 OUT2.0



DIN 51097

A+B



BS 7976-2:2002  
(CEN/TS 16165, Annex C)  
Pendulum Friction Test

≥ 36 Wet



B.C.R.A. Rep. CEC/81

Asciutto > 0,40 /  
Bagnato > 0,40



ANSI A137.1-2012 (BOT3000)

> 0,42 Wet



## The prestige of wood

---

La serie Mansion è nata da una ricerca approfondita sulle tendenze dell'interior design, che sempre più spesso ripropongono nell'arredo di ambienti contemporanei l'effetto vissuto dei legni antichi. La collezione evoca il pregio e il fascino del legno piallato a mano, del restauro a stuccatura di antiche tavole e dei segni lasciati dal tempo sulle essenze lignee, valorizzando l'effetto vintage del materiale naturale attraverso le più innovative tecnologie ceramiche.

The Mansion range is the result of painstaking research into the growing trend to recreate the aged appearance of antique wood in contemporary interiors. The collection evokes the prestige and charm of hand-shaved wood, old floorboards restored using plaster and the worn appearance of wood, enhancing the vintage effect of this natural material with the most innovative techniques in ceramic production.

La série Mansion est le fruit d'une recherche approfondie sur les tendances de la décoration d'intérieur qui proposent de plus en plus souvent dans les intérieurs modernes les effets vécus des bois anciens. Cette collection évoque le prestige et le charme du bois raboté à la main, de la restauration par masticage de vieilles planches et des signes laissés sur le bois au fil du temps, mettant en valeur l'effet vintage du matériau brut grâce aux technologies céramiques de pointe.

Die Serie Mansion ist aus einer tiefgehenden Untersuchung der Trends im Innendesign entstanden, die bei der Einrichtung von zeitgemäßen Räumen immer öfter die gelebte Optik von altem Holz vorschlagen. Die Kollektion erinnert an die Kostbarkeit und den Reiz von handgehobeltem Holz, der Restaurierung von alten Holztafeln durch Verspachteln und der Spuren, die die Zeit auf den Holzarten zurückgelassen hat, wobei die Vintage-Optik des natürlichen Materials mit Hilfe der innovativen Keramiktechnologien zur Geltung gebracht wird.

De serie Mansion ontstond na een diepgaande research naar de tendensen binnen de interior design sector, waarbij steeds vaker in een hedendaags interieur visuele effecten van antiek hout worden geïntroduceerd. De collectie doet denken aan de prestige en charme van handgepolijst hout, de restauratie van antieke tafels met kneedbaar hout en de tekens achtergebleven door de tijd heen op doorleefd hout. Zo ontstaat een vintage effect op natuurlijke materialen, bekomen door de meest innovatieve keramische technieken.

La serie Mansion nace de una profunda búsqueda sobre las tendencias del diseño de interiores, que cada vez reproducen con más frecuencia el efecto de maderas antiguas en muebles contemporáneos. La colección evoca el mérito y fascinación de la madera tratada a mano, de la restauración de mesas antiguas y signos de envejecimiento de los tipos de maderas, valorizando el efecto vintage del material natural a través de las tecnologías cerámicas más innovadoras.

9 mm

75x75/30°x30° R

Gres porcellanato  
Porcelain stoneware  
Grès cérame fin vitrifié  
Feinsteinzeug  
Porseleingres  
Gres porcelánico



V4  
Substantial



Lounge 75x75/30"x30" R

LL32



Court 75x75/30"x30" R

LI71



Hall 75x75/30"x30" R

LI72



Arcade 75x75/30"x30" R

LI70



Library 75x75/30"x30" R

LI73

Imballi/Packing/Emballage/Verpackungseinheiten/Verpakking/Embalajes

	pcs x box	m <sup>2</sup> / m x box	kg x box	box x pallet	m <sup>2</sup> x pallet	kg x pallet
75x75/30"x30"	2	1,1250	24,00	42	47,25	1008,00

Court 75x75/30"x30" R

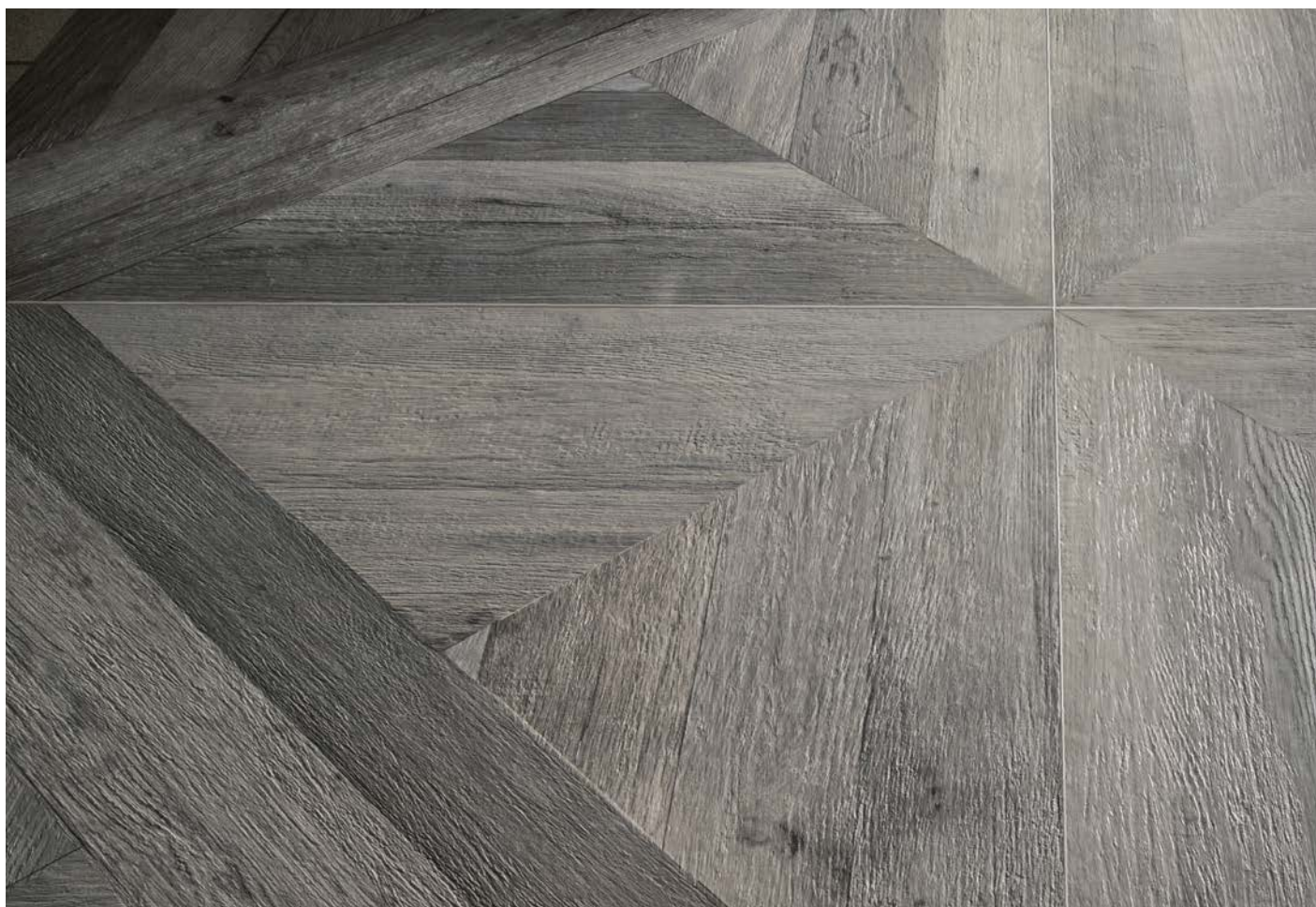

Caratteristiche/Features/Caracteristiques/Eigenschaften/Eigenschappen/Características



UNI EN ISO 10545/14

Classe 5 / Class 5



DIN 51130

R10



DIN 51097

A+B



B.C.R.A. Rep. CEC/81

Asciutto > 0,40 / Bagnato > 0,40



ANSI A137.1-2012 (BOT3000)

> 0,42 Wet

Nickel 120x120/48"x48" R



## Concrete blend

Mold nasce dal ricordo delle miscele manuali di abili carpentieri e artigiani che mescolano con i propri attrezzi il cemento insieme a pietrisco di varie dimensioni. La collezione è caratterizzata da agglomerati di ghiaia di forme eterogenee disseminati in modo irregolare che ricordano le gettate di calcestruzzo fresco nelle casseforme o negli stampi, spazi in cui il materiale cementizio viene plasmato fino ad avere una propria forma. Mold è declinata nelle colorazioni Mist (bianco), Cinder (grigio chiaro), Nickel (grigio fango) e Iron (grigio scuro) e disponibile nei formati 120x120, 60x120, 75x150, 75x75, 60x60 e 30x60 anche con finitura Soft.

Mold evokes the concrete manually mixed by skilled carpenters and craftsmen, who use their tools to blend it with rocks and gravel of varying coarseness. The collection stands out for gravel clusters of varying sizes scattered randomly, which remind of fresh concrete casts in formworks or moulds, two techniques where concrete material is processed until it reaches a shape of its own. Mold is produced in Mist (white), Cinder (light grey), Nickel (muddy grey) and Iron (dark grey) and available in the 120x120, 60x120, 75x150, 75x75, 60x60 and 30x60 sizes, also with the Soft finish.

Mold évoque les mélanges que les artisans et les charpentiers réalisent savamment avec leurs outils, en malaxant le ciment à de la bécaille de différentes tailles. La collection est caractérisée par des agglomérats de graviers de formes hétérogènes et disséminés de manière irrégulière, qui rappellent des coulées de béton frais à l'intérieur de moules ou de coffrages, éléments qui permettaient de mouler le matériau à base de ciment pour lui donner la forme voulue. Mold se décline dans les coloris Mist (blanc), Cinder (gris clair), Nickel (gris couleur argile) et Iron (gris foncé) et est disponible aux formats 120x120, 60x120, 75x150, 75x75, 60x60 et 30x60, ceci également en finition Soft.

Mold entsteht aus der Erinnerung an manuelle Gemische von geschickten Schreibern und Handwerkern, die mit ihren Geräten den Zement zusammen mit Schotter verschiedener Größen vermischen. Die Kollektion ist charakterisiert von Kiesagglomeraten verschiedener Größen, die auf unregelmäßige Weise verstreut sind und an den Ausguß von Frischbeton in Verschalungen oder Formen erinnert, in denen das Zementmaterial dann geformt wird bis es eine eigene Gestalt erhält. Mold wird in den Farben Mist (weiß), Cinder (hellgrau), Nickel (fangograu) und Iron (dunkelgrau) angeboten und ist auch in Soft-Endausführung verfügbar in den Formaten 120x120, 60x120, 75x150, 75x75, 60x60 und 30x60.

Mold is ontstaan uit de herinnering aan het handmengen van bekwame timmer- en ambachtslieden, die het beton met hun eigen gereedschap samen met grind van verschillende afmetingen mengden. De collectie wordt gekenmerkt door op onregelmatige wijze verspreide agglomeraties van grind met verschillende vormen, die doen denken aan vers gegoten beton in bekistingen of mallen, ruimten waarin het betonhoudend materiaal wordt vormgegeven tot het zijn eigen vorm heeft. Mold is verkrijgbaar in de kleuren Mist (wit), Cinder (lichtgrijs), Nikkel (moddergrijs) en IJzer (donkergrijs) en in de maten 120x120, 60x120, 75x150, 75x75, 60x60 en 30x60, eveneens met zachte afwerking.

Mold nace de la preparación de morteros elaborados manualmente por carpinteros y artesanos hábiles y expertos que mezclaban con sus herramientas el cemento con piedras en bruto trituradas de diferentes tamaños. La colección está caracterizada por los aglomerados de grava de formas heterogéneas diseminadas de manera irregular evocando las mezclas de hormigón fresco en los encofrados o en los moldes, espacios en los que el material de cemento se moldea hasta obtener una forma propia. Mold está disponible en los colores Mist (blanco), Cinder (gris claro), Nickel (gris lodo) e Iron (gris oscuro) y en los formatos 120x120, 60x120, 75x150, 75x75, 60x60 e 30x60 también con acabado Soft.

### 9 mm

120x120/48"x48" R  
120x120/48"x48" Soft R  
60x120/24"x48" R  
60x120/24"x48" Soft R  
75x150/30"x60" R  
75x150/30"x60" Soft R  
75x75/30"x30" R  
75x75/30"x30" Soft R  
60x60/24"x24" R  
60x60/24"x24" Soft R  
30x60/12"x24" R  
30x60/12"x24" Soft R

### 20 mm OUT2.0

90x90/36"x36" R

Gres porcellanato  
Porcelain stoneware  
Grès cérame fin vitrifié  
Feinsteinzeug  
Porseleingres  
Gres porcelánico



V3  
Moderate

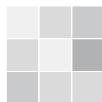

<b>Mist</b>	<b>120x120/48"x48" R</b>	<b>MY50</b>
	<b>120x120/48"x48" Soft R</b>	<b>MY51</b>
	<b>60x120/24"x48" R</b>	<b>NC94</b>
	<b>60x120/24"x48" Soft R</b>	<b>NC95</b>
	<b>75x150/30"x60" R</b>	<b>MW61</b>
	<b>75x150/30"x60" Soft R</b>	<b>MW65</b>
	<b>75x75/30"x30" R</b>	<b>MX97</b>
	<b>75x75/30"x30" Soft R</b>	<b>MX98</b>
	<b>60x60/24"x24" R</b>	<b>MX66</b>
	<b>60x60/24"x24" Soft R</b>	<b>MX67</b>
	<b>30x60/12"x24" R</b>	<b>MX34</b>
	<b>30x60/12"x24" Soft R</b>	<b>MX35</b>

<b>Cinder</b>	<b>120x120/48"x48" R</b>	<b>MY46</b>
	<b>120x120/48"x48" Soft R</b>	<b>MY47</b>
	<b>60x120/24"x48" R</b>	<b>NC90</b>
	<b>60x120/24"x48" Soft R</b>	<b>NC91</b>
	<b>75x150/30"x60" R</b>	<b>MW59</b>
	<b>75x150/30"x60" Soft R</b>	<b>MW63</b>
	<b>75x75/30"x30" R</b>	<b>MX93</b>
	<b>75x75/30"x30" Soft R</b>	<b>MX94</b>
	<b>60x60/24"x24" R</b>	<b>MX62</b>
	<b>60x60/24"x24" Soft R</b>	<b>MX63</b>
	<b>30x60/12"x24" R</b>	<b>MX30</b>
	<b>30x60/12"x24" Soft R</b>	<b>MX31</b>
	<b>90x90/36"x36" R OUT2.0</b>	<b>MJ94</b>



<b>Iron</b>	<b>120x120/48"x48" R</b>	<b>MY48</b>
	<b>120x120/48"x48" Soft R</b>	<b>MY49</b>
	<b>60x120/24"x48" R</b>	<b>NC92</b>
	<b>60x120/24"x48" Soft R</b>	<b>NC93</b>
	<b>75x150/30"x60" R</b>	<b>MW60</b>
	<b>75x150/30"x60" Soft R</b>	<b>MW64</b>
	<b>75x75/30"x30" R</b>	<b>MX95</b>
	<b>75x75/30"x30" Soft R</b>	<b>MX96</b>
	<b>60x60/24"x24" R</b>	<b>MX64</b>
	<b>60x60/24"x24" Soft R</b>	<b>MX65</b>
	<b>30x60/12"x24" R</b>	<b>MX32</b>
	<b>30x60/12"x24" Soft R</b>	<b>MX33</b>

<b>Nickel</b>	<b>120x120/48"x48" R</b>	<b>MY52</b>
	<b>120x120/48"x48" Soft R</b>	<b>MY53</b>
	<b>60x120/24"x48" R</b>	<b>NC96</b>
	<b>60x120/24"x48" Soft R</b>	<b>NC97</b>
	<b>75x150/30"x60" R</b>	<b>MW62</b>
	<b>75x150/30"x60" Soft R</b>	<b>MW66</b>
	<b>75x75/30"x30" R</b>	<b>MX99</b>
	<b>75x75/30"x30" Soft R</b>	<b>MY00</b>
	<b>60x60/24"x24" R</b>	<b>MX68</b>
	<b>60x60/24"x24" Soft R</b>	<b>MX69</b>
	<b>30x60/12"x24" R</b>	<b>MX36</b>
	<b>30x60/12"x24" Soft R</b>	<b>MX37</b>

Mist 75x75/30"x30" Soft R

Mold  
188/189



## Pezzi speciali/Trim tiles/Pieces speciales/Formteile/Speciale delen/Piezas especiales

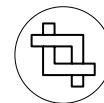

### Battiscopa

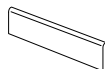

7x75/2<sup>7/8</sup>"x30" R

Cinder  
Iron  
Mist  
Nickel

**MX08**  
**MX09**  
**MX10**  
**MX11**

7x60/2<sup>7/8</sup>"x24" R

Cinder  
Iron  
Mist  
Nickel

**MW96**  
**MW97**  
**MW98**  
**MW99**

## Imballi/Packing/Emballage/Verpackungseinheiten/Verpakking/Embalajes

	pcs x box	m <sup>2</sup> / m x box	kg x box	box x pallet	m <sup>2</sup> x pallet	kg x pallet
120x120/48"x48"	2	2,8800	58,00	20	57,60	1160,00
60x120/24"x48"	2	1,4400	31,50	35	50,40	1102,50
75x150/30"x60"	1	1,1250	24,50	25	28,13	612,50
75x75/30"x30"	2	1,1250	24,00	42	47,25	1008,00
60x60/24"x24"	3	1,0800	21,35	40	43,20	854,00
30x60/12"x24"	7	1,2600	25,00	40	50,40	1000,00
90x90/36"x36" <b>OUT2.0</b>	1	0,8100	37,60	18	14,58	676,80
7x75/2 <sup>7/8</sup> "x33" Battiscopa	10	7,5000	11,00	54	405,00	594,00
7x60/2 <sup>7/8</sup> "x24" Battiscopa	10	6,0000	9,00	70	420,00	630,00

The MATT and SOFT finishes are recommended for interior floors, walls, and exterior walls in both residential and commercial applications. Mold is not recommended for exterior horizontal surfaces or exterior paving, and they are not recommended for ramps application. The SOFT finish is not recommended for interior floors in entrance areas if joined to outdoor in commercial applications.

## SOFT Caratteristiche/Features/Caracteristiques/Eigenschaften/Eigenshappen/Características



UNI EN ISO 10545/14

Classe 5 / Class 5



B.C.R.A. Rep. CEC/81

Asciutto > 0,40 /  
Bagnato > 0,40



ANSI A137.1-2012 (BOT3000)

> 0,42 Wet

## MATT Caratteristiche/Features/Caracteristiques/Eigenschaften/Eigenshappen/Características



UNI EN ISO 10545/14

Classe 5 / Class 5



DIN 51130

R10  
R11 OUT2.0



DIN 51097

A+B  
A+B+C OUT2.0



BS 7976-2:2002 (CEN/TS 16165,  
Annex C) Pendulum Friction Test

≥ 36 Wet



B.C.R.A. Rep. CEC/81

Asciutto > 0,40 /  
Bagnato > 0,40



ANSI A137.1-2012 (BOT3000)

> 0,42 Wet

Cinder 75x150/30"x60" R

Mold  
190/191







## A mineral journey

Un viaggio virtuale nel mondo delle pietre più ricercate, un universo millenario che diventa il riferimento per questa selezione di materiali naturali unici e fortemente riconoscibili. Una lunga tradizione per superfici di origine minerale, che fanno parte della storia dell'uomo ma si attualizzano integrandosi con l'interior design contemporaneo. Una collezione articolata e volutamente eterogenea che raccoglie materiali lapidei con diverse provenienze, caratteristiche, sfumature, ma tutti accomunati da un appeal elegante e da texture molto grafiche, particolarmente in linea con i trend più attuali.

A virtual journey in the world of the most sought after stones, a millenary world which set the background for the selection of unique and charismatic natural materials. A traditional material for surfaces made of inorganic matter that are part of human history, but that keeps revitalizing and fits perfectly in contemporary interior design. A rich and heterogeneous collection of stone materials with varied origins, several hues and traits, all elegant and with outstanding graphic designs perfectly in line with the latest trends.

Un voyage virtuel dans l'univers des pierres les plus recherchées, un univers millénaire qui est à la base d'une sélection de matières naturelles uniques et à la forte identité. Une longue tradition pour des surfaces de matières inorganiques qui font partie de l'histoire de l'homme mais qui se renouvellent en s'intégrant avec la décoration d'intérieurs contemporaine. Une collection riche et intentionnellement hétérogène réunissant des matériaux pierreux de différentes origines, ayant des nuances et des caractéristiques variées, mais tous très élégants et aux graphismes raffinés, parfaitement en ligne avec les tendances les plus actuelles.

Eine virtuelle Reise in die Welt der erlesensten Gesteine – ein jahrtausendealtes Universum, das zum Anhaltspunkt für diese einzigartige und äußerst charakteristische Auswahl an Naturmaterialien dient. Die Oberflächen anorganischen Ursprungs, die Bestandteil der Menschheitsgeschichte sind, haben eine lange Tradition, gewinnen jedoch nun erneut an Aktualität, indem sie in die zeitgenössische Innenarchitektur integriert werden. Es handelt sich um eine gewollt heterogene Kollektion, die unterschiedliches Gesteinsmaterial bezüglich des Ursprungs, der Eigenschaften und der Nuancen in sich vereint. All diesen Gesteinen ist ihre elegante Wirkung und auffallend graphische Maserung gemein, mit denen sie den derzeitigen Trends im Interior Design entsprechen.

Een virtuele reis door de wereld van de meest gezochte steensoorten ter wereld, een duizendjarig universum dat het referentiepunt wordt voor deze selectie unieke en duidelijk herkenbare natuurlijke materialen. Oppervlakken van anorganische oorsprong hebben een lange traditie en maken deel uit de geschiedenis van de mens, maar worden eigentijds wanneer zij in hedendaags interior design worden gebruikt. Een gearticuleerde en bewust heterogene collectie steenmaterialen die qua herkomst, eigenschappen, schakeringen verschillen, maar een elegant appeal en zeer grafische texturen met elkaar gemeen hebben die perfect bij de meest actuele trends aansluiten.

Un viaje virtual en el mundo de las piedras más buscadas, un universo milenario que se ha convertido en referencia para seleccionar estos materiales naturales únicos y muy reconocidos. Una larga tradición para superficies de matriz inorgánica, que son parte de la historia del hombre y se actualizan integrándose al diseño interior contemporáneo. Una colección articulada y conscientemente heterogénea que reúne materiales de piedra de diferentes orígenes, características, gradaciones, pero todo unidos por un fascino sensual elegante y por texturas muy gráficas, en particular, de acuerdo con las últimas tendencias.

✂ 9 mm

60x60/24"x24" R  
30x60/12"x24" R  
15x30/6"x12"  
15x15/6"x6" R

✂ 9,5 mm

45x45/18"x18"

✂ 20 mm OUT2.0

40x120/16"x48" R  
60x60/24"x24" R



V2  
Slight \*



V3  
Moderate



**Guyana Ivory \*** 60x60/24"x24" R MB84  
30x60/12"x24" R NF44



**Savoie Ash** 60x60/24"x24" R MB90  
30x60/12"x24" R NF41  
40x120/16"x48" R OUT2.0 MH90  
60x60/24"x24" R OUT2.0 MC64



**Pacific Grey** 60x60/24"x24" R MB89  
30x60/12"x24" R NF42



**Guyana Almond \*** 60x60/24"x24" R MB83  
30x60/12"x24" R NF45



**Muschelkalk Brown** 60x60/24"x24" R MB88  
30x60/12"x24" R NF43

V4  
Substantial



**Barge** 60x60/24"x24" R **LE73**  
**Giallo** 30x60/12"x24" R **NF48**  
 45x45/18"x18" **LE75**



**Barge** 60x60/24"x24" R **LE74**  
**Grigio** 30x60/12"x24" R **NF47**  
 45x45/18"x18" **LE76**  
 15x30/6"x12" **LG35**  
 60x60/24"x24" R **OUT2.0** **LG98**



**Bavaria** 30x60/12"x24" R **NF46**  
 15x15/6"x6" R **LI27**

Decori/Decorative Motif/Decors/  
Dekore/Decoraties/Decoraciones



26 soggetti diversi  
formato 15x15  
(miscelazione casuale)/  
26 assorted motifs 15x15  
size (random mix)/  
26 sujets differents format  
15x15 (melange aleatoire)/  
26 verschiedene  
Motive Format 15x15  
(Zufallsmischung)/  
26 verschillende  
ontwerpen in 15x15  
(willekeurig gemengd)/  
26 motivos diferentes  
formato 15x15  
(mezcla casual)



**Bavaria** 15x15/6"x6" R **LI28**  
**Fossil**



V2  
Slight \*



V3  
Moderate

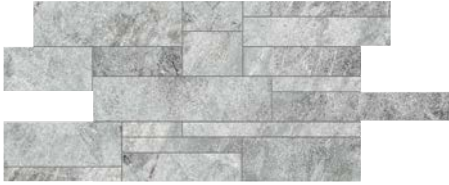

Savoie 30x60/12"x24" R MC20  
Ash  
Muretto

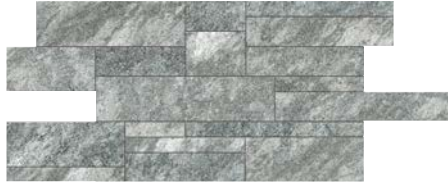

Pacific 30x60/12"x24" R MC19  
Grey  
Muretto



Guyana 30x60/12"x24" R MC14  
Ivory \*  
Muretto

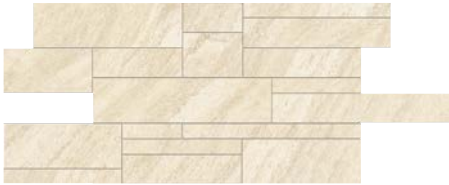

Guyana 30x60/12"x24" R MC13  
Almond \*  
Muretto

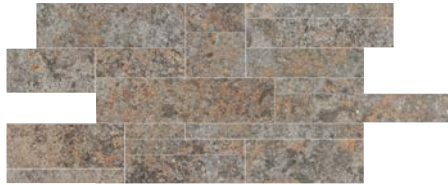

Muschelkalk 30x60/12"x24" R MC18  
Brown  
Muretto

Pacific Grey 60x60/24"x24" R — Guyana Ivory 30x60/12"x24" R — Guyana Ivory Muretto 30x60/12"x24" R



## Pezzi speciali/Trim tiles/Pieces speciales/Formteile/Speciale delen/Piezas especiales



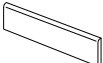





	<b>10x60/4"x24"</b>		<b>8,5x45/3 1/2"x18"</b>	
	Barge Giallo R Barge Grigio R Bavaria	<b>LF42</b> <b>LF43</b> <b>LI41</b>	Barge Giallo Barge Grigio	<b>LF44</b> <b>LF45</b>

	<b>16,5x30/6 3/4"x12"</b>	
	Barge Grigio	<b>LF95</b>

## Imballi/Packing/Emballage/Verpackungseinheiten/Verpakking/Embalajes

	pcs x box	m <sup>2</sup> / m x box	kg x box	box x pallet	m <sup>2</sup> x pallet	kg x pallet
<b>60x60/24"x24"</b>	3	1,0800	21,35	40	43,20	854,00
<b>30x60/12"x24"</b>	7	1,2600	25,00	40	50,40	1000,00
<b>45x45/18"x18"</b>	5	1,0125	20,60	33	33,41	679,80
<b>15x30/6"x12"</b>	24	1,0800	22,90	44	47,52	1007,60
<b>15x15/6"x6"</b>	24	0,5400	10,70	88	47,52	941,60
<b>40x120/16"x48" OUT2.0</b>	2	0,9600	41,50	24	23,04	996,00
<b>60x60/24"x24" OUT2.0</b>	2	0,7200	32,40	30	21,60	972,00
<b>30x60/12"x24" Muretto</b>	5	0,9000	19,50	24	21,60	468,00
<b>10x60/4"x24" Battiscopa</b>	10	6,0000	11,50	60	360,00	690,00
<b>8,5x45/3 1/2"x18" Battiscopa</b>	8	3,6000	6,50	69	248,40	448,50
<b>16,5x30/6 3/4"x12" Elemento Elle</b>	16	0,7920	22,35	24	19,01	536,40

## Caratteristiche/Features/Caracteristiques/Eigenschaften/Eigenschappen/Características

					
UNI EN ISO 10545/14	DIN 51130	DIN 51097	BS 7976-2:2002 (CEN/TS 16165, Annex C) Pendulum Friction Test	B.C.R.A. Rep. CEC/81	ANSI A137.1-2012 (BOT3000)
Classe 5 / Class 5	R10 Savoie, Pacific, Guyana, Muschelkalk R11 Barge, Bavaria R11 OUT2.0	A+B A+B+C OUT2.0	≥ 36 Wet	Asciutto > 0,40 / Bagnato > 0,40	> 0,42 Wet

Bavaria 30x60/12"x24" R — 15x15/6"x6" R — Fossil 15x15/6"x6" R

Petrae  
198/199





Grigio 120×120/48"×48" R



# Pietra di Cembra

# 200/201

## Timeless pathways

La collezione racconta le atmosfere naturali e montane della Val di Cembra in Trentino Alto Adige, luogo di estrazione del porfido e si ispira a questa roccia di origine vulcanica che viene reinterpretata esaltandone la struttura, caratterizzata dalla presenza di piccoli cristalli di quarzo, asperità ed avvallamenti più o meno accentuati. Pietra di Cembra offre una grande versatilità: grazie ai numerosi formati e spessori disponibili, è adatta agli ambienti esterni ma anche a quelli interni, confermando un rinnovato gusto per l'utilizzo del porfido nell'interior design.

The collection recounts the natural and mountainous atmospheres of Val di Cembra in Trentino Alto Adige, a place where porphyry is quarried and it draws its inspiration from this particular volcanic rock, which is reinterpreted while enhancing its structure, distinguished by the presence of tiny quartz crystals, and bumps and grooves that are accentuated to different extents. Pietra di Cembra offers extensive versatility: thanks to the multiple sizes and thicknesses available, it is suitable for outdoor settings as well as indoor ones, confirming a renewed preference for the use of porphyry in interior design.

La collection représente les ambiances naturelles et montagnardes de la Vallée de Cembra, dans la région Trentin-Haut-Adige, lieu d'extraction du porphyre. Elle s'inspire de cette roche d'origine volcanique qu'elle réinterprète en exaltant sa structure, caractérisée par la présence de petits cristaux de quartz, de bosselures et de flaches plus ou moins accentuées. Pietra di Cembra est très polyvalente: grâce à ses nombreux formats et épaisseurs, elle est idéale pour les extérieurs mais aussi pour les intérieurs, confirmant le retour du porphyre dans le design d'intérieur.

Die Kollektion schildert die Entstehung der Natur- und Berglandschaft von Val di Cembra im Trentino Südtirol, wo Porphyr gewonnen wird. Von diesem vulkanischen Gestein wird das neu interpretierte Material inspiriert, und zeigt so eine mit mehr oder weniger deutlich sichtbaren kleinen Quarzkristallen, Rauheiten und Vertiefungen charakterisierte Struktur. Pietra di Cembra ermöglicht eine äußerst vielseitige Anwendung: Dank zahlreicher verfügbarer Formaten und Stärken ist dieses Material sowohl für den Außen- als auch für den Innenbereich geeignet, was einen neuen Trend für den Einsatz von Porphyr für die Innenausstattung bewirkt.

De collectie evoceert de natuurlijke en bergachtige sfeer van de Val di Cembra in Trentino Alto Adige, een plaats waar porfier wordt gewonnen en is ook geïnspireerd door dit stollingsgesteente, omgevormd tot een betere structuur, met kleine kwarts kristallen, oneffenheden en min of meer geaccentueerde holtes. Pietra di Cembra biedt een grote veelzijdigheid: dankzij de vele afmetingen en diktes die beschikbaar zijn, is het geschikt voor zowel binnen als buiten, een bevestiging van de hernieuwde smaak voor het gebruik van porfier in de binnenhuisinrichting.

La colección quiere reflejar la belleza natural de las montañas de Val di Cembra, en Trentino Alto Adige, famosas por ser un lugar de extracción del pórfido. Esta roca volcánica sirve de inspiración para luego reinterpretarla mejorando su estructura, que se caracteriza por la presencia de pequeños cristales de cuarzo, asperezas y hendiduras más o menos acentuadas. Pietra di Cembra ofrece una gran versatilidad: gracias a los muchos tamaños y grosores disponibles, puede destinarse tanto a espacios exteriores como interiores, lo que confirma un uso renovado del pórfido en el diseño de interiores.

### ✂ 9 mm

120x120/48"x48" R  
60x120/24"x48" R  
60x60/24"x24" R  
60x60/24"x24" GRIP R  
30x60/12"x24" R  
30x60/12"x24" GRIP R  
Arco R  
Coda di Pavone R

### ✂ 20 mm OUT2.0

90x90/36"x36" R  
45x90/18"x36" R  
Set 90x90/36"x36" R  
Arco Mix R  
Coda di Pavone Mix R

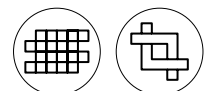

Gres porcellanato  
Porcelain stoneware  
Grès cérame fin vitrifié  
Feinsteinzeug  
Porseleingres  
Gres porcelánico

V3  
Moderate

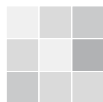

**Grigio**

120x120/48"x48" R	NQ29
60x120/24"x48" R	NQ93
60x60/24"x24" R	NQ96
60x60/24"x24" GRIP R	NR98
30x60/12"x24" R	NQ99
30x60/12"x24" GRIP R	NU88
90x90/36"x36" R OUT 2.0	NP86
45x90/18"x36" R OUT 2.0	NR02



**Naturale**

120x120/48"x48" R	NQ30
60x120/24"x48" R	NQ94
60x60/24"x24" R	NQ97
60x60/24"x24" GRIP R	NR99
30x60/12"x24" R	NR00
30x60/12"x24" GRIP R	NU89
90x90/36"x36" R OUT 2.0	NP87
45x90/18"x36" R OUT 2.0	NR03



**Ruggine**

120x120/48"x48" R	NQ28
60x120/24"x48" R	NQ95
60x60/24"x24" R	NQ98
60x60/24"x24" GRIP R	NS00
30x60/12"x24" R	NR01
90x90/36"x36" R OUT 2.0	NP88
45x90/18"x36" R OUT 2.0	NR04



Set Grigio 90x90/36"x36" R OUT2.0 NQ82



Set Naturale 90x90/36"x36" R OUT2.0 NQ83



Set Ruggine 90x90/36"x36" R OUT 2.0 NP84

SET 90x90/36"x36" OUT2.0:  
1 pc 45x90/18"x36"  
1 pc 45x45/18"x18"  
1 pc 22,5x45/9"x18"  
2 pcs 22,5x22,5/9"x9"

Set Grigio 90x90/36"x36" R OUT2.0

Pietra di Cembra  
202/203





V3  
Moderate



Coda di Pavone Grigio

NS40



Coda di Pavone Naturale

NS41



Coda di Pavone Ruggine

NS42



Coda di Pavone Mix OUT 2.0

NQ80

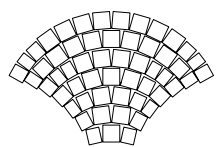

74/29<sup>3/4</sup>"

111,5/44<sup>3/4</sup>"





V3  
Moderate



Arco Grigio R

NS43



Arco Naturale R

NS44



Arco Ruggine R

NS45



Arco Mix R OUT 2.0

NQ81

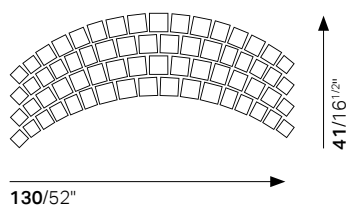





## Pezzi speciali/Trim tiles/Pieces speciales/Formteile/Speciale delen/Piezas especiales

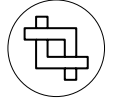

### Battiscopa

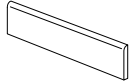

7x60/2<sup>7/8</sup>"x24" R

Grigio **NQ67**  
Naturale **NQ68**  
Ruggine **NQ69**

## Imballi/Packing/Emballage/Verpackungseinheiten/Verpakking/Embalajes

	pcs x box	m <sup>2</sup> / m x box	kg x box	box x pallet	m <sup>2</sup> / m x pallet	kg x pallet
120x120/48"x48"	2	2,8800	58,00	20	57,60	1160,00
60x120/24"x48"	2	1,4400	31,50	35	50,40	1102,50
60x60/24"x24"	3	1,0800	21,35	40	43,20	854,00
30x60/12"x24"	7	1,2600	25,00	40	50,40	1000,00
<b>Coda di Pavone</b>	1	0,4900	7,08	32	15,68	226,56
<b>Arco</b>	1	0,5800	9,00	32	18,56	288,00
<b>90x90/36"x36" OUT2.0</b>	1	0,8100	37,60	18	14,58	676,80
<b>45x90/18"x36" OUT2.0</b>	2	0,8100	37,60	27	21,87	999,00
<b>Set 90x90/36"x36" OUT2.0</b>	1	0,8100	37,60	18	14,58	676,80
<b>Arco Mix OUT2.0</b>	1	0,5800	18,00	16	9,28	288,00
<b>Coda di Pavone Mix OUT2.0</b>	1	0,4900	14,15	16	7,84	226,40
<b>7x60/2<sup>7/8</sup>"x24" R Battiscopa</b>	10	6,0000	9,00	70	420,00	630,00

## Caratteristiche/Features/Caracteristiques/Eigenschaften/Eigenschappen/Características



UNI EN ISO 10545/14

Classe 5 / Class 5



DIN 51130

R10  
R11 GRIP  
R11 OUT2.0



DIN 51097

A+B  
A+B+C OUT2.0



BS 7976-2:2002 (CEN/TS 16165,  
Annex C) Pendulum Friction Test

≥ 36 Wet



B.C.R.A. Rep. CEC/81

Asciutto > 0,40 /  
Bagnato > 0,40



ANSI A137.1-2012 (BOT3000)

> 0,42 Wet

Naturale 120×120/48"×48" R

Pietra di Cembra  
208/209





# Pietre di Borgogna

# 210/211

## Timeless elegance

La collezione trae ispirazione dalla pietra d'origine calcarea tradizionale della Borgogna, regione della Francia nota in tutto il mondo per i grandi vini e per il ricco patrimonio architettonico. Refin reinterpreta su ceramica questo pregiato materiale ampiamente usato nella storia dell'architettura, coniugando le qualità estetiche con le eccellenti caratteristiche tecniche del grès porcellanato Refin. Ceramiche nei toni del bianco, beige e grigio, con sfumature equilibrate e venature naturali. Irregolari tracce che evocano i residui fossili di conchiglie impressi nella pietra naturale a cui la collezione è ispirata.

The ceramic collection takes its inspiration from a natural limestone which can be traditionally found in Bourgogne, a French region that is internationally renowned for its prestigious wines and its architectural beauty. Refin reinterprets this precious material, that has been widely used in the history of architecture, combining its natural appeal with the excellent technical performances of Refin's top quality porcelain stoneware. Ceramics in white, beige and grey tints, with a balanced shading and a natural veining. Irregular stripes evoking the fossil shells which can be found on the surface of the natural stone from which the collection takes its inspiration.

La collection tire son inspiration de la pierre d'origine calcaire traditionnelle de la Bourgogne, région de France célèbre dans le monde entier pour ses grands vins et son riche patrimoine architectural. Refin, réinterprète sur la céramique ce matériau précieux largement utilisé dans l'histoire de l'architecture, en associant les qualités esthétiques avec les excellentes caractéristiques techniques du grès cérame Refin. Céramiques de couleurs blanche, beige et grise aux nuances équilibrées et aux veines naturelles. Empreintes irrégulières évoquant les résidus fossiles de coquillages imprimés dans la pierre naturelle de laquelle la collection s'inspire.

Die Inspiration zu dieser Kollektion stammt vom traditionellen Kalkstein aus dem Burgund, einer Region in Frankreich, die in der ganzen Welt für ihre großartigen Weine und ihr reiches architektonisches Kulturerbe bekannt ist. Refin interpretiert dieses kostbare und im Lauf der Geschichte der Architektur großzügig verwendete Material in Keramik neu und vereint so die ästhetischen Qualitäten mit den ausgezeichneten technischen Merkmalen des Feinsteinzeugs von Refin. Keramik in den Farbtönen von weiß, beige und grau mit ausgewogenen Nuancen und natürlichen Maserungen. Unregelmäßige Spuren, die an die im Naturstein, an dem die Kollektion inspiriert ist, eingprägten fossilen Muschelreste erinnern.

De collectie is geïnspireerd op de traditionele kalksteen uit Bourgondië, de Franse regio die in heel de wereld bekend staat voor zijn prestigieuze wijnsoorten en rijk architectonisch erfgoed. Refin brengt een keramische versie uit van dit kostbaar materiaal dat veelvuldig gebruikt werd in de architectuurgeschiedenis en combineert zo zijn opmerkelijke esthetische kenmerken met de excellente technische prestaties van de gres porcellanato van de firma. Keramiek in de wit-, beige- en grijstinten, met evenwichtige nuanceringen en natuurlijke nerftekeningen. Onregelmatige tekens doen denken aan schelpfossielen afgedrukt in natuursteen - de inspiratiebron van de collectie.

La colección se inspira en la piedra de origen calcárea tradicional de Borgoña, región de Francia conocida en todo el mundo por los grandes vinos y por el rico patrimonio arquitectónico que comprende castillos, abadías y construcciones románicas. Refin reinterpreta a través de la cerámica este valioso material ampliamente usado a lo largo de la historia de la arquitectura, conjugando sus características estéticas con las excelentes cualidades técnicas del gres porcelánico Refin. Se caracterizan por tonalidades naturales que abarcan del blanco al beige al gris, con matices claros y oscuros interrumpidos por puntitos y vetas más o menos marcados y por irregulares trazos grises que evocan los residuos fósiles de conchas típicamente grabados en la piedra natural que inspira la colección.

✂ 9 mm

60x60/24"x24" R  
60x60/24"x24" R Strutt.  
30x60/12"x24" R  
30x60/12"x24" R Strutt.  
30x30/12"x12"  
30x30/12"x12" Strutt.

✂ 9,5 mm

45x45/18"x18"  
45x45/18"x18" Strutt.

✂ 20 mm OUT2.0

60x60/24"x24" R Strutt.

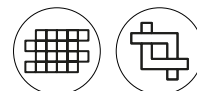

Gres porcellanato  
Porcelain stoneware  
Grès cérame fin vitrifié  
Feinsteinzeug  
Porseleingres  
Gres porcelánico

V3  
Moderate



**Diamante** 60x60/24"x24" R I762  
30x60/12"x24" R NF11  
45x45/18"x18" I976  
30x30/12"x12" NG84



**Sabbia** 60x60/24"x24" R I764  
30x60/12"x24" R NF10  
45x45/18"x18" I978  
30x30/12"x12" NG85



**Terre** 60x60/24"x24" R I765  
30x60/12"x24" R NF09  
45x45/18"x18" I980  
30x30/12"x12" NG86



**Diamante Strutt.** 60x60/24"x24" R L228  
30x60/12"x24" R NF08  
45x45/18"x18" L236  
30x30/12"x12" NG87  
60x60/24"x24" R OUT2.0 LG95



**Sabbia Strutt.** 60x60/24"x24" R I766  
30x60/12"x24" R NF07  
45x45/18"x18" I979  
30x30/12"x12" NG88  
60x60/24"x24" R OUT2.0 LG96



**Terre Strutt.** 60x60/24"x24" R I767  
30x60/12"x24" R NF06  
45x45/18"x18" I981  
30x30/12"x12" NG89



V3  
Moderate

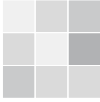

Diamante 30x30/12"x12"  
Mosaico

L150



Sabbia 30x30/12"x12"  
Mosaico

L152



Terre 30x30/12"x12"  
Mosaico

L154



Diamante 30x30/12"x12"  
Strutt.  
Mosaico

L231



Sabbia 30x30/12"x12"  
Strutt.  
Mosaico

L153



Terre 30x30/12"x12"  
Strutt.  
Mosaico

L155

## Pezzi speciali/Trim tiles/Pieces speciales/Formteile/Speciale delen/Piezas especiales



### Battiscopa



10x60/4"x24" R		8,5x45/3 <sup>1/2</sup> "x18"	
Diamante	<b>I934</b>	Diamante	<b>I940</b>
Sabbia	<b>I936</b>	Sabbia	<b>I942</b>
Terre	<b>I938</b>	Terre	<b>I944</b>
Diamante Strutt.	<b>L233</b>	Diamante Strutt.	<b>L232</b>
Sabbia Strutt.	<b>I937</b>	Sabbia Strutt.	<b>I943</b>
Terre Strutt.	<b>I939</b>	Terre Strutt.	<b>I945</b>

## Imballi/Packing/Emballage/Verpackungseinheiten/Verpakking/Embalajes

	pcs x box	m <sup>2</sup> / m x box	kg x box	box x pallet	m <sup>2</sup> x pallet	kg x pallet
60x60/24"x24"	3	1,0800	21,35	40	43,20	854,00
30x60/12"x24"	7	1,2600	25,00	40	50,40	1000,00
45x45/18"x18"	5	1,0125	20,60	33	33,41	679,80
30x30/12"x12"	12	1,0800	20,50	48	51,84	984,00
60x60/24"x24" <b>OUT2.0</b>	2	0,7200	33,60	30	21,60	1008,00
30x30/12"x12" Mosaico	11	0,9900	19,00	18	17,82	342,00
10x60/4"x24" Battiscopa	10	6,0000	11,50	60	360,00	690,00
8,5x45/3 <sup>1/2</sup> "x18" Battiscopa	8	3,6000	6,50	69	248,40	448,50

## Caratteristiche/Features/Caracteristiques/Eigenschaften/Eigenshappen/Características



UNI EN ISO 10545/14

Classe 5 / Class 5



DIN 51130

R9  
R11 Strutturato  
R11 OUT2.0



DIN 51097

A+B+C Strutturato  
A+B+C OUT2.0



B.C.R.A. Rep. CEC/81

Asciutto > 0,40 / Bagnato > 0,40



ANSI A137.1-2012 (BOT3000)

> 0,42 Wet

Sabbia 60x60/24"x24" R





Nickel 75x150/30"x60" Soft R — Brick W 25x150/10"x60" R



## Solid surface

Utilizzato dai più grandi maestri dell'architettura contemporanea, il cemento sta assumendo un nuovo ruolo passando da materiale da costruzione ad elemento esteriormente finito per le superfici dell'architettura. Dall'analisi del cemento in questa sua funzione più attuale nasce Plain. La collezione è caratterizzata da lievi nuvolature e pattern più o meno marcati, da leggere microfessure tipiche di quando il volume di calcestruzzo si contrae per effetto delle escursioni termiche e da piccoli forellini (pitting) creati dalle bolle d'aria rimaste intrappolate fra il getto e la cassaforma. La superficie, ricca di dettagliati segni e sfumature, appare a distanza come uno spazio solido, uniforme e compatto.

Used by the greatest masters of contemporary architecture, concrete is taking a new role, moving from being a construction material to being a surface finish for architectural projects. Plain stems from analysing concrete in this latter, newer function. The collection stands out for slight clouding and more or less marked patterns, light micro-cracks, that usually form when the concrete volume shrinks by effect of thermal excursion and small holes (pitting) formed by air bubbles trapped between the cast and the formwork. The surface is rich with detailed marks and shades; from a distance it appears as a solid, consistent and compact space.

Utilisé par les plus grands maîtres de l'architecture contemporaine, le ciment assume aujourd'hui un nouveau rôle, en passant de matériau de construction à élément extérieurement fini pour les surfaces de l'architecture. C'est l'analyse de la fonction la plus actuelle du ciment qui a donné naissance à Plain. Cette collection est caractérisée par de légers effets nébulisés et par des motifs plus ou moins marqués, sans oublier les petites microfissures typiques de lorsque le volume du béton se contracte par effet de l'amplitude thermique, et les petits trous (pitting) créés par les bulles d'air restées emprisonnées entre la coulée et le coffrage. De loin, cette surface riche en détails de signes et nuances, apparaît comme un espace solide, compact et uniforme.

Der von den größten Meistern der zeitgenössischen Architektur verwendete Zement ist dabei eine neue Rolle einzunehmen, indem er vom Baumaterial zu einem fertigen Außenelement für architektonische Oberflächen wird. Aus der Betrachtung des Zements in dieser neuesten Funktion heraus entsteht Plain. Die Kollektion ist von leichten Wolkeneffekten und mehr oder weniger ausgeprägten Mustern geprägt, von leichten Mikrospalten, die typischerweise auftreten, wenn sich das Betonvolumen aufgrund der Temperaturschwankungen kontrahiert sowie von kleinen Löchern (Pitting), die durch sich zwischen dem Ausguß und der Verschalung bildende Wasserblasen entstehen. Die an detaillierten Zeichen und Nuancen reiche Oberfläche sieht von Weitem solide, gleichmäßig und kompakt aus.

Beton wordt gebruikt door de grootste meesters van de hedendaagse architectuur en krijgt een nieuwe rol: van bouw materiaal tot een aan de buitenkant afgewerkt element voor architectonische oppervlakken. Plain is het resultaat van een onderzoek van het beton in zijn allernieuwste functie. De collectie wordt gekenmerkt door een licht wolkeffect en min of meer gemarkeerde motiefjes, door lichte microscheuren, die kenmerkend zijn voor wanneer het volume van het beton krimpt als gevolg van temperatuurschommelingen en door kleine putjes (pitting) die zijn ontstaan uit luchtbelletjes die tussen het gegoten beton en de bekisting zijn achtergebleven. Het oppervlak, rijk aan gedetailleerde tekens en nuances, lijkt van een afstand een solide, gelijkmatige en compacte ruimte.

Utilizado por los más grandes maestros de la arquitectura contemporánea, el cemento está asumiendo un papel cada vez más significativo, pasando de un material de construcción a un elemento acabado en el exterior para las superficies arquitectónicas. Plain nace del análisis del cemento con esta versión más actual. La colección está caracterizada por ligeras nubes y pattern más o menos marcados, por leves microgrietas típicas de cuando el volumen de hormigón se contrae por efecto de las variaciones térmicas y por pequeños agujeros (pitting) creados por burbujas de aire quedadas atrapadas entre la colada y el encofrado. La superficie, rica de signos y matices detallados, se ve desde lejos como un espacio sólido, uniforme y compacto.

✂ 6 mm

120x278/48"x110" R

✂ 9 mm

120x120/48"x48" R  
120x120/48"x48" Soft R  
60x120/24"x48" R  
60x120/24"x48" Soft R  
75x150/30"x60" R  
75x150/30"x60" Soft R  
75x75/30"x30" R  
75x75/30"x30" Soft R  
60x60/24"x24" R  
60x60/24"x24" Soft R  
30x60/12"x24" R  
30x60/12"x24" Soft R

✂ 9,5 mm

45x45/18"x18" Soft

✂ 20 mm OUT2.0

90x90/36"x36" R

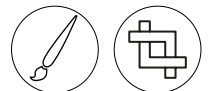

Gres porcellanato  
Porcelain stoneware  
Grès cérame fin vitrifié  
Feinsteinzeug  
Porseleingres  
Gres porcelánico

V3  
Moderate

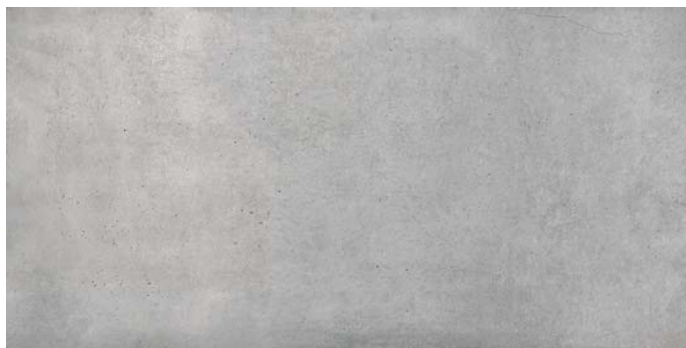
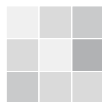

<b>Mist</b>	<b>120x120/48"x48" R</b>	<b>MY16</b>
	<b>120x120/48"x48" Soft R</b>	<b>MY17</b>
	<b>60x120/24"x48" R</b>	<b>NC41</b>
	<b>60x120/24"x48" Soft R</b>	<b>NC42</b>
	<b>75x150/30"x60" R</b>	<b>MW53</b>
	<b>75x150/30"x60" Soft R</b>	<b>MW57</b>
	<b>75x75/30"x30" R</b>	<b>MY08</b>
	<b>75x75/30"x30" Soft R</b>	<b>MY09</b>
	<b>60x60/24"x24" R</b>	<b>MX58</b>
	<b>60x60/24"x24" Soft R</b>	<b>MX59</b>
	<b>30x60/12"x24" R</b>	<b>MX42</b>
	<b>30x60/12"x24" Soft R</b>	<b>MX43</b>
	<b>45x45/18"x18" Soft</b>	<b>MY64</b>

<b>Cinder</b>	<b>120x278/48"x110" R</b>	<b>MK84</b>
	<b>120x120/48"x48" R</b>	<b>MY12</b>
	<b>120x120/48"x48" Soft R</b>	<b>MX80</b>
	<b>60x120/24"x48" R</b>	<b>NC37</b>
	<b>60x120/24"x48" Soft R</b>	<b>NC38</b>
	<b>75x150/30"x60" R</b>	<b>MW47</b>
	<b>75x150/30"x60" Soft R</b>	<b>MW55</b>
	<b>75x75/30"x30" R</b>	<b>MY04</b>
	<b>75x75/30"x30" Soft R</b>	<b>MY05</b>
	<b>60x60/24"x24" R</b>	<b>MX54</b>
	<b>60x60/24"x24" Soft R</b>	<b>MX55</b>
	<b>30x60/12"x24" R</b>	<b>MX38</b>
	<b>30x60/12"x24" Soft R</b>	<b>MX39</b>
	<b>45x45/18"x18" Soft</b>	<b>MY62</b>
	<b>90x90/36"x36" R OUT2.0</b>	<b>MJ93</b>



<b>Iron</b>	<b>120x120/48"x48" R</b>	<b>MY14</b>
	<b>120x120/48"x48" Soft R</b>	<b>MY15</b>
	<b>60x120/24"x48" R</b>	<b>NC39</b>
	<b>60x120/24"x48" Soft R</b>	<b>NC40</b>
	<b>75x150/30"x60" R</b>	<b>MW52</b>
	<b>75x150/30"x60" Soft R</b>	<b>MW56</b>
	<b>75x75/30"x30" R</b>	<b>MY06</b>
	<b>75x75/30"x30" Soft R</b>	<b>MY07</b>
	<b>60x60/24"x24" R</b>	<b>MX56</b>
	<b>60x60/24"x24" Soft R</b>	<b>MX57</b>
	<b>30x60/12"x24" R</b>	<b>MX40</b>
	<b>30x60/12"x24" Soft R</b>	<b>MX41</b>
	<b>45x45/18"x18" Soft</b>	<b>MY63</b>

<b>Nickel</b>	<b>120x278/48"x110" R</b>	<b>MK85</b>
	<b>120x120/48"x48" R</b>	<b>MY13</b>
	<b>120x120/48"x48" Soft R</b>	<b>MX79</b>
	<b>60x120/24"x48" R</b>	<b>NC43</b>
	<b>60x120/24"x48" Soft R</b>	<b>NC44</b>
	<b>75x150/30"x60" R</b>	<b>MW54</b>
	<b>75x150/30"x60" Soft R</b>	<b>MW58</b>
	<b>75x75/30"x30" R</b>	<b>MY10</b>
	<b>75x75/30"x30" Soft R</b>	<b>MY11</b>
	<b>60x60/24"x24" R</b>	<b>MX60</b>
	<b>60x60/24"x24" Soft R</b>	<b>MX61</b>
	<b>30x60/12"x24" R</b>	<b>MX44</b>
	<b>30x60/12"x24" Soft R</b>	<b>MX45</b>
	<b>45x45/18"x18" Soft</b>	<b>MY65</b>

Cinder 75x150/30"x60" Soft R

Plain  
218/219



V2  
Slight

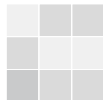

Brick W 25x150/10"x60" R LT86

Decori/Decorative Motif/Decors/  
Dekore/Decoraties/Decoraciones



Fragment 75x150/30"x60" Soft R MY26

4 soggetti diversi formato 75x150 (miscelazione casuale)/  
4 assorted motifs 75x150 size (random mix)/  
4 sujets differents format 75x150 (melange aleatoire)/  
4 Verschiedene Motive Format 75x150 (Zufallsmischung)/  
4 verschillende ontwerpen in 75x150 (willekeurig gemengd)/  
4 motivos diferentes formato 75x150 (mezcla aleatoria)



4 soggetti diversi formato 75x150 - 20 soggetti diversi formato 30x60 (miscelazione casuale)/  
4 assorted motifs 75x150 size - 20 assorted motifs 30x60 size (random mix)/  
4 sujets differents format 75x150 - 20 sujets differents format 30x60 (melange aleatoire)/  
4 Verschiedene Motive Format 75x150 - 20 Verschiedene Motive Format 30x60 (Zufallsmischung)/  
4 verschillende ontwerpen in 75x150 - 20 verschillende ontwerpen in 30x60 (willekeurig gemengd)/  
4 motivos diferentes formato 75x150 - 20 motivos diferentes formato 30x60 (mezcla aleatoria)

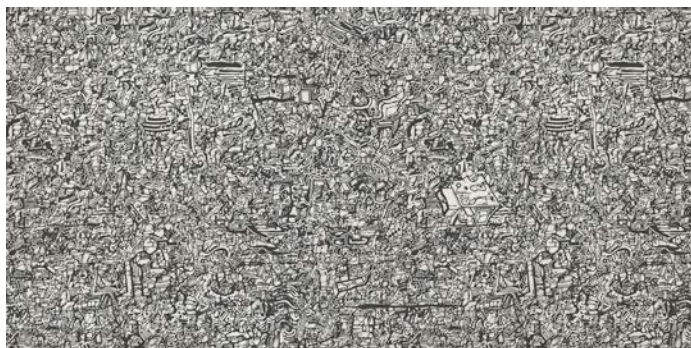

Plain Doodle

Plain 75x150/30"x60" Soft R MY20  
Doodle 30x60/12"x24" Soft R MY24

Plain Doodle 75x150/30"x60" Soft R



Doodle: design: Pierluigi Lanzillotta

## Pezzi speciali/Trim tiles/Pieces speciales/Formteile/Speziale delen/Piezas especiales

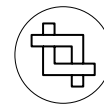

Battiscopa	7x75/2 <sup>7/8</sup> "x30" R	7x60/2 <sup>7/8</sup> "x24" R	8,5x45/3 <sup>1/2</sup> "x18"
	Cinder Iron Mist Nickel	<b>MX12</b> <b>MX13</b> <b>MX14</b> <b>MX15</b>	Cinder Iron Mist Nickel
		<b>MW88</b> <b>MW89</b> <b>MW90</b> <b>MW91</b>	Cinder Iron Mist Nickel
			<b>MY68</b> <b>MY70</b> <b>MY71</b> <b>MY69</b>

## Imballi/Packing/Emballage/Verpackungseinheiten/Verpakking/Embalajes

	pcs x box	m <sup>2</sup> / m x box	kg x box	box x pallet	m <sup>2</sup> x pallet	kg x pallet
<b>120x178/48"x110"</b>	1	3,3360	49,56	18	60,05	892,08
<b>120x120/48"x48"</b>	2	2,8800	58,00	20	57,60	1160,00
<b>60x120/24"x48"</b>	2	1,4400	31,50	35	50,40	1102,50
<b>75x150/30"x60"</b>	1	1,1250	24,50	25	28,13	612,50
<b>75x75/30"x30"</b>	2	1,1250	24,00	42	47,25	1008,00
<b>60x60/24"x24"</b>	3	1,0800	21,35	40	43,20	854,00
<b>30x60/12"x24"</b>	7	1,2600	25,00	40	50,40	1000,00
<b>45x45/18"x18"</b>	5	1,0125	20,60	33	33,41	679,80
<b>25x150/10"x60" Brick</b>	3	1,1250	24,50	30	33,75	735,00
<b>90x90/36"x36" OUT2.0</b>	1	0,8100	37,60	18	14,58	676,80
<b>7x75/2<sup>7/8</sup>"x33" Battiscopa</b>	10	7,5000	11,00	54	405,00	594,00
<b>7x60/2<sup>7/8</sup>"x24" Battiscopa</b>	10	6,0000	9,00	70	420,00	630,00
<b>8,5x45/3<sup>1/2</sup>"x18" Battiscopa</b>	8	3,6000	6,50	69	248,40	448,50

The MATT and SOFT finishes are recommended for interior floors, walls, and exterior walls in both residential and commercial applications. Plain is not recommended for exterior horizontal surfaces or exterior paving, and they are not recommended for ramps application. The SOFT finish is not recommended for interior floors in entrance areas if joined to outdoor in commercial applications.

## SOFT Caratteristiche/Features/Caracteristiques/Eigenschaften/Eigenshappen/Características



UNI EN ISO 10545/14

Classe 5 / Class 5



B.C.R.A. Rep. CEC/81

Asciutto > 0,40 /  
Bagnato > 0,40



ANSI A137.1-2012 (BOT3000)

> 0,42 Wet

## MATT Caratteristiche/Features/Caracteristiques/Eigenschaften/Eigenshappen/Características



UNI EN ISO 10545/14

Classe 5 / Class 5



DIN 51130

R10  
R11 OUT2.0



DIN 51097

A+B  
A+B OUT2.0



BS 7976-2:2002 (CEN/TS 16165,  
Annex C) Pendulum Friction Test

≥ 36 Wet



B.C.R.A. Rep. CEC/81

Asciutto > 0,40 /  
Bagnato > 0,40



ANSI A137.1-2012 (BOT3000)

> 0,42 Wet

Fragment 75x150/30"x60" Soft R

Plain  
222/223





Powder 45x90/18 x36" R - 22,5x90/9" x36" R



## Post-industrial material

Inedito materiale ibrido di matrice industriale, Plant si configura come un legno-cemento dal gusto *délabré* e dalla spiccata connotazione contemporanea. Le evidenti scalfiture superficiali, i segni di usura e i particolari colori scelti per la palette confermano quell'immaginario underground a cui la collezione è ispirata.

La nuance neutra Powder e il più consueto grigio Ash, affiancano infatti il beige Clay, il corda scuro Rope, una tinta decisamente rossastra Copper e Iron, un marrone scuro tendente al nero. Sono previsti 7 formati, tutti di medie e grandi dimensioni per esaltare la stonalizzazione delle superfici posate: 75x150, 25x150, 45x90, 22,5x90, 75x75, 60x60 e 30x60

A brand-new hybrid industrial material, Plant is a wood-cement with a used-look appeal and a decidedly contemporary allure.

The conspicuous scratching on the surface, the signs of wear and tear and the distinctive colours all contribute to shaping the underground atmosphere the collection takes its inspiration from. The neutral Powder and the more classic Ash grey are joined by Clay beige, dark Rope, a markedly reddish shade, Copper, and Iron, a dark blackish-brown shade. The tiles come in 7 medium and large sizes, ideal for enhancing the shading effect once laid: 75x150, 25x150, 45x90, 22,5x90, 75x75, 60x60 and 30x60.

Matière hybride de matrice industrielle sans précédent, Plant se présente comme un bois-ciment à l'aspect *délabré* et au remarquable cachet contemporain. Les surfaces ostensiblement éraflées, affichant leur usure, et les couleurs particulières choisies pour en composer la palette, confirment l'esprit underground dont la collection s'inspire. La nuance neutre Powder et le gris Ash, plus traditionnel, accompagnent en effet le beige Clay, Rope, un chanvre foncé, Copper, une teinte résolument roussâtre, et Iron, un marron foncé tirant sur le noir.

7 formats, tous de moyennes et grandes dimensions, pour rehausser la stonalisation des surfaces posées : 75x150, 25x150, 45x90, 22,5x90, 75x75, 60x60 et 30x60.

Das brandneue Hybridmaterial industrieller Prägung Plant gestaltet sich als Holz-Zement im *Délabré*-Stil mit einem ausgeprägten zeitgemäßen Charakter.

Die deutlichen oberflächlichen Ritze, die Verschleißspuren und speziellen für die Farbpalette gewählten Farben betonen die Underground-Ideen, von denen die Inspiration zu dieser Kollektion stammt. So bestehen das neutrale Nuance Powder und das geläufigere Grau Ash neben dem Beigeton Clay, dem dunklen Ecu Rope, dem eindeutig rötlichen Farbton Copper und Iron, einem beinahe schwarzen Dunkelbraun.

7 Formate sind vorgesehen, deren Abmessungen jeweils mittelgroß bis groß sind, um die Abtönung der verlegten Oberflächen zur Geltung zu bringen: 75x150, 25x150, 45x90, 22,5x90, 60x60 und 30x60.

Plant, een onuitgegeven industrieel gemodelleerd hybridemateriaal, profileert zich als een hout-cementhybride voor een "*délabré*" en uitdrukkelijk hedendaags getint interieur.

Opvallende inkervingen op de oppervlakte, tekens van slijtage en een specifiek uitgekozen kleurenpalet bevestigen allen de underground uitstraling waarop de collectie zich inspireert. De neutrale Powder tint en het meer gebruikelijke Ash grijs gaan samen met het lichtbeige Clay, het donkerbeige Rope, het uitgesproken roodgetinte Copper en het donkerbruine – bijna zwarte – Iron.

Beschikbaar in 7 middelgrote tot grote formaten, om de typische kleurschakering van de oppervlakken te benadrukken: 75x150, 25x150, 45x90, 22,5x90, 75x75, 60x60 en 30x60.

Plant, un material híbrido e inédito de matriz industrial, se configura como un elemento de madera y cemento de estilo *délabré* y con una marcada connotación contemporánea.

Los evidentes arañazos en la superficie, los signos de desgaste y los tonos especiales elegidos para la paleta de color confirman el imaginario underground en el que se inspira la colección. El tono neutro Powder y el habitual gris Ash acompañan al beige Clay y al crudo oscuro Rope; un color rojizo intenso, Copper y Iron, un color marrón oscuro que tiende al negro.

Hay 7 formatos de medidas medianas y grandes para resaltar la destonación del material colocado: 75x150, 25x150, 45x90, 22,5x90, 75x75, 60x60 y 30x60.

✂ 9 mm

75x150/30"x60" R  
25x150/10"x60" R  
75x75/30"x30" R  
45x90/18"x36" R  
22,5x90/9"x36" R  
60x60/24"x24" R  
30x60/12"x24" R

✂ 20 mm OUT.2.0

40x120/16"x48" R

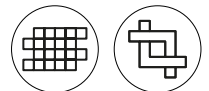

V4  
Substantial



**Powder**

75x150/30"x60" R	LZ42
25x150/10"x60" R	LZ32
75x75/30"x30" R	MD02
45x90/18"x36" R	LY19
22,5x90/9"x36" R	LZ20
60x60/24"x24" R	LY24
30x60/12"x24" R	NE95



**Ash**

75x150/30"x60" R	LZ33
25x150/10"x60" R	LZ29
75x75/30"x30" R	MT32
45x90/18"x36" R	LY41
22,5x90/9"x36" R	LZ17
60x60/24"x24" R	LY36
30x60/12"x24" R	NE99
40x120/16"x48" R	MH91



**Clay**

75x150/30"x60" R	LZ40
25x150/10"x60" R	LZ31
75x75/30"x30" R	MU21
45x90/18"x36" R	LY16
22,5x90/9"x36" R	LZ18
60x60/24"x24" R	LY21
30x60/12"x24" R	NE98



**Rope**

75x150/30"x60" R	LX82
25x150/10"x60" R	LX83
75x75/30"x30" R	MD03
45x90/18"x36" R	LY20
22,5x90/9"x36" R	LZ21
60x60/24"x24" R	LY25
30x60/12"x24" R	NE94
40x120/16"x48" R	MZ46



**Copper**

75x150/30"x60" R	LZ34
25x150/10"x60" R	LZ30
75x75/30"x30" R	MU22
45x90/18"x36" R	LY17
22,5x90/9"x36" R	LZ19
60x60/24"x24" R	LY22
30x60/12"x24" R	NE97



**Iron**

75x150/30"x60" R	LZ41
25x150/10"x60" R	LZ39
75x75/30"x30" R	MU23
45x90/18"x36" R	LY18
22,5x90/9"x36" R	LZ43
60x60/24"x24" R	LY23
30x60/12"x24" R	NE96

Rope 75x150/30"x60" R

Plant  
226/227





V4  
Substantial



**Powder** 28,5x56,5/11 1/2"x22 3/4" R LY95  
**Muretto 3D**



**Clay** 28,5x56,5/11 1/2"x22 3/4" R LY93  
**Muretto 3D**



**Ash** 28,5x56,5/11 1/2"x22 3/4" R LY92  
**Muretto 3D**



**Rope** 28,5x56,5/11 1/2"x22 3/4" R LY96  
**Muretto 3D**



**Copper** 28,5x56,5/11 1/2"x22 3/4" R LY94  
**Muretto 3D**



**Iron** 28,5x56,5/11 1/2"x22 3/4" R LZ44  
**Muretto 3D**

3 soggetti diversi formato 28,5x56,5 (miscelazione casuale)/  
3 assorted motifs 28,5x56,5 size (random mix)/  
3 sujets differents format 28,5x56,5 (melange aleatoire)/  
3 verschiedene Motive Format 28,5x56,5 (Zufallsmischung)/  
3 verschillende ontwerpen in 28,5x56,5 (willekeurig gemengd)/  
3 motivos diferentes formato 28,5x56,5 (mezcla casual)

Pezzi speciali/Trim tiles/Pieces speciales/Formteile/Speciale delen/Piezas especiales



Battiscopa



7x75/2<sup>7/8</sup>"x30" R

Ash	MU13
Clay	MU14
Copper	MU15
Iron	MU16
Powder	MU17
Rope	MU18

7x60/2<sup>7/8</sup>"x24" R

Ash	LY39
Clay	LX97
Copper	LX98
Iron	LX99
Powder	LY00
Rope	LY01

Imballi/Packing/Emballage/Verpackungseinheiten/Verpakking/Embalajes

	pcs x box	m <sup>2</sup> / m x box	kg x box	box x pallet	m <sup>2</sup> x pallet	kg x pallet
75x150/30"x60"	1	1,1250	24,50	25	28,13	612,50
25x150/10"x60"	3	1,1250	24,00	30	33,75	720,00
75x75/30"x30"	2	1,1250	24,00	42	47,25	1008,00
45x90/18"x36"	3	1,2150	25,80	36	43,74	928,80
22,5x90/9"x36"	6	1,2150	25,80	36	43,74	928,80
60x60/24"x24"	3	1,0800	21,35	40	43,20	854,00
30x60/12"x24"	7	1,2600	25,00	40	50,40	1000,00
40x120/16"x48" OUT2.0	2	0,9600	41,50	24	23,04	996,00
28,5x56,5/11 <sup>1/2</sup> "x22 <sup>3/4</sup> " Muretto 3D	3	0,4831	12,00	15	7,25	180,00
7x75/2 <sup>7/8</sup> "x30" Battiscopa	10	7,5000	11,00	54	405,00	594,00
7x60/2 <sup>7/8</sup> "x24" Battiscopa	10	6,0000	9,00	70	420,00	630,00

MATT Caratteristiche/Features/Caracteristiques/Eigenschaften/Eigenschappen/Características



UNI EN ISO 10545/14

Classe 5 / Class 5



DIN 51130

R10  
R11 OUT2.0



DIN 51097

A+B  
A+B+C OUT2.0



B.C.R.A. Rep. CEC/81

Asciutto > 0,40 /  
Bagnato > 0,40



ANSI A137.1-2012 (BOT3000)

> 0,42 Wet

Grigia 75x75/30"x30" R



## The tradition reloaded

Il fascino della pietra leccese si ritrova in questa proposta ceramica dall'aspetto raffinato: la ricercatezza delle nuances naturali si abbina sia ai contesti classici, nel formato 60x60 con finitura anticata, sia a quelli contemporanei con la posa dei formati più grandi. Il nome evoca una collezione pregiata in cui il dettaglio della texture, lo studio dei contrasti e l'attenzione agli equilibri delle inclusioni fossili definiscono superfici particolarmente armoniche. Un'eleganza senza tempo, enfatizzata dalla scelta di cinque tonalità morbide che vanno dal bianco al fango, passando per una calda sfumatura gold con due più neutre grigie.

All the allure of Leccese stone is evident here on this sophisticated ceramic surface, in natural nuances that are ideal for both classical settings – in the 60x60 size with aged finish – and more contemporary environments, using the larger sizes. The name is indicative of a prestigious collection in which the detail of the texture, the carefully studied contrasts and painstaking attention to balancing the fossil inserts combine to create wonderfully smooth, appealing finishes. Timeless elegance, enhanced by the five soft shades ranging from white to mud grey, as well as a warm gold nuance and two more neutral shades of grey.

Le charme des pierres de Lecce se retrouve dans cette surface céramique à l'aspect raffiné: la sophistication des nuances naturelles s'associe aussi bien aux contextes classiques, dans le format 60x60 avec une finition vieillie, qu'aux contextes contemporains, avec la pose de plus grands formats. Le nom évoque une collection raffinée, où le détail de la texture, l'étude des contrastes et l'attention prêtée aux équilibres des inclusions fossiles définissent des finitions de surface particulièrement harmonieuses. Une élégance atemporelle, émise par le choix de cinq tonalités douces qui vont du blanc à la couleur boue, tout en passant par une chaude nuance or et deux plus neutres grises.

Der Reiz der Pietra leccese ist bei diesem Vorschlag einer Keramikoberfläche mit raffiniertem Aussehen wiederzufinden: Die Ausgesuchtheit der natürlichen Nuancen passt zu den klassischen Kontexten im Format 60x60 mit Antik-Optik ebenso wie zu den aktuellen, in denen größere Formate verlegt werden. Der Name lässt an eine prestigereiche Kollektion denken, bei der das Detail der Textur, die sorgfältige Wahl der Kontraste und die Aufmerksamkeit auf das Gleichgewicht der Fossileneinschlüsse für die Definition von besonders harmonischen Oberflächenausfertigungen sorgen. Eine zeitlose Eleganz, die durch die Wahl von vier weichen Farbtönen unterstrichen wird, die von Weiß über eine warme Goldnuance und zwei neutrale Graunuancen bis Schlammbräun reichen.

De charme van natuursteen uit het Italiaanse Lecce komt tot uiting in dit geraffineerd keramisch oppervlak: opmerkelijke natuurlijke nuances met formaat 60x60 en verouderde afwerking passen perfect in een klassiek interieur, de grotere formaten creëren dan weer een hedendaagse omgeving. Zijn naam roept een kostbare collectie op, waar structuurdetails, contraststudie en aandacht voor een evenwichtige verdeling van de fossielen instaan voor bijzonder harmonische oppervlakken. Tijdloze elegantie wordt benadrukt door de keuze van vier zachte tinten, gaande van wit tot moddergrijs, met daartussen het warme gold en twee neutrale grijs tinten.

La belleza de la piedra de Lecce se halla en esta superficie cerámica de aspecto refinado: la sofisticación de los matices naturales se combina con los contextos clásicos en el formato 60x60 con acabado antiguo, y con los modernos gracias a la colocación de formatos más grandes. Su nombre evoca una colección refinada, en la que el detalle de las texturas, el estudio de los contrastes y la atención puesta en los equilibrios de las incrustaciones fósiles definen el acabado de superficies particularmente armónicas. Una elegancia intemporal, enfatizada por la elección de cinco tonos suaves que van desde el blanco al barro, pasando por un cálido matiz gold y dos más neutro gris.

✂ 9 mm

75x150/30"x60" R  
75x75/30"x30" R  
60x60/24"x24" R  
30x60/12"x24" R

✂ 20 mm OUT2.0

60x60/24"x24" R





V3  
Moderate



**Bianca**    **75x150/30"x60" R**    **LS64**  
**75x75/30"x30" R**    **LU24**  
**60x60/24"x24" R**    **LU29**  
**30x60/12"x24" R**    **NE93**



**Cenere**    **75x150/30"x60" R**    **LT38**  
**75x75/30"x30" R**    **LU25**  
**60x60/24"x24" R**    **LU30**  
**30x60/12"x24" R**    **NE92**



**Grigia**    **75x150/30"x60" R**    **LS67**  
**75x75/30"x30" R**    **LU26**  
**60x60/24"x24" R**    **LU31**  
**30x60/12"x24" R**    **NE91**



**Paglierina**    **60x60/24"x24" R**    **LU32**  
**30x60/12"x24" R**    **NE90**



**Tortora**    **60x60/24"x24" R**    **LU33**  
**30x60/12"x24" R**    **NE89**

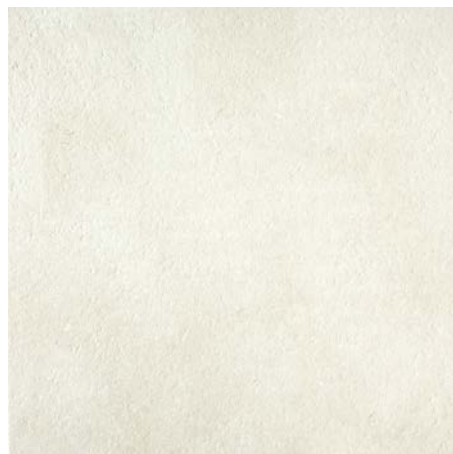

**Bianca** 60x60/24"x24" R **LT32**  
**Anticata** 30x60/12"x24" R **NE88**



**Cenere** 60x60/24"x24" R **LT36**  
**Anticata** 30x60/12"x24" R **NE87**



**Grigia** 60x60/24"x24" R **LT34**  
**Anticata** 30x60/12"x24" R **NE86**  
60x60/24"x24" R **OUT2.0** **LU50**



**Paglierina** 60x60/24"x24" R **LT33**  
**Anticata** 30x60/12"x24" R **NE85**



**Tortora** 60x60/24"x24" R **LT35**  
**Anticata** 30x60/12"x24" R **NE84**



**Deco** 30x60/12"x24" R **NI42**  
**Genere**



**Deco** 30x60/12"x24" R **LU43**  
**Grigia**



**Deco** 30x60/12"x24" R **LU41**  
**Paglierina**



**Deco** 30x60/12"x24" R **LU42**  
**Tortora**



**Geometrico** 30x60/12"x24" R **LU39**



**Bianca Muretto** 30x30/12"x12" R **LT43**



**Cenere Muretto** 30x30/12"x12" R **LT44**



**Grigia Muretto** 30x30/12"x12" R **LT45**

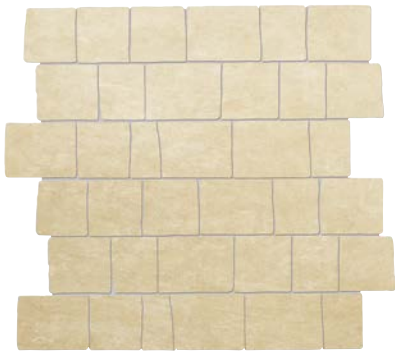

**Paglierina Muretto** 30x30/12"x12" R **LT46**



**Tortora Muretto** 30x30/12"x12" R **LT47**

## Pezzi speciali/Trim tiles/Pieces speciales/Formteile/Speziale delen/Piezas especiales



### Battiscopa

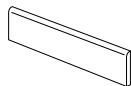

7x75/2<sup>7/8</sup>"x30" R

Bianca  
Cenere  
Grigia

LT57  
LT58  
LT59

7x60/2<sup>7/8</sup>"x24" R

Bianca  
Cenere  
Grigia  
Paglierina  
Tortora

LT66  
LT67  
LT68  
LT69  
LT70

## Imballi/Packing/Emballage/Verpackungseinheiten/Verpakking/Embalajes

	pcs x box	m <sup>2</sup> / m x box	kg x box	box x pallet	m <sup>2</sup> x pallet	kg x pallet
75x150/30"x60"	1	1,1250	24,50	25	28,13	612,50
75x75/30"x30"	2	1,1250	24,00	42	47,25	1008,00
60x60/24"x24"	3	1,0800	21,35	40	43,20	854,00
30x60/12"x24"	7	1,2600	25,00	40	50,40	1000,00
30x60/12"x24" Deco Cenere	7	1,0800	23,40	40	43,20	936,00
30x60/12"x24" Deco/Geometrico	6	1,0800	23,40	40	43,20	936,00
60x60/24"x24" OUT2.0	2	0,7200	32,40	30	21,60	972,00
30x30/12"x12" Muretto	11	0,9900	19,00	18	17,82	342,00
7x75/2 <sup>7/8</sup> "x30" Battiscopa	10	7,5000	11,00	54	405,00	594,00
7x60/2 <sup>7/8</sup> "x24" Battiscopa	10	6,0000	9,00	70	420,00	630,00

## Caratteristiche/Features/Caracteristiques/Eigenschaften/Eigenschappen/Características



UNI EN ISO 10545/14

Classe 5 / Class 5



DIN 51130

R9  
R10 Anticata  
R11 OUT2.0



DIN 51097

A+B  
A+B+C Anticata  
A+B+C OUT2.0



BS 7976-2:2002  
(CEN/TS 16165, Annex C)  
Pendulum Friction Test

≥ 36 Wet Anticata



B.C.R.A. Rep. CEC/B1

Asciutto > 0,40 /  
Bagnato > 0,40



ANSI A137.1-2012 (BOT3000)

> 0,42 Wet





## The new classic

Il rinnovato gusto per i materiali lapidei si declina nella collezione Prestigio: importanti marmi naturali, provenienti dalle più rinomate cave italiane ed europee, sono proposti valorizzando le loro tipiche sfumature di colore e le venature originali – talvolta delicate altre volte più marcate – messe in risalto dalla preziosa finitura lucida. La collezione diventa così espressione di uno stile classico che viene rivisitato in un'elegante chiave moderna, grazie anche alla scelta di formati di grandi dimensioni.

Stone materials are back in the spotlight once again in the Prestigio collection: top-class natural marble from the most renowned quarries in Italy and Europe whose typical nuances of colour and original veining patterns – sometimes delicate, others more marked – are enhanced by the beautifully polished finish. The collection is thus the expression of classic style given an elegant modern twist thanks also to the large sizes.

La collection Prestigio exprime une tendance renouvelée pour les matériaux pierreux: d'importants marbres naturels, extraits des carrières italiennes et européennes les plus renommées sont proposés en valorisant leurs nuances de couleur caractéristiques et leurs veinures originales – tantôt délicates tantôt plus marquées – mises en relief par une précieuse finition brillante. La collection devient ainsi l'expression d'un style classique revisité avec modernité et élégance, grâce aussi au choix de formats de grandes dimensions.

Die wiederentdeckte Vorliebe für Steinmaterialien nimmt bei der Kollektion Prestigio Form an: Bedeutende natürliche Marmorarten, die aus den berühmtesten Steinbrüchen Italiens und Europas stammen, werden in einer Version vorgeschlagen, die ihre typischen Farbnuancen und die ursprünglichen Maserungen – die manchmal zart und andere Male markanter sein können – hervorhaben, da sie durch die Läppung, die für eine kostbare glänzende Ausfertigung sorget, zur Geltung gebracht werden. Die Kollektion wird so zum Ausdruck eines klassischen Stils, der in einem eleganten modernen Schlüssel neu interpretiert wird, was auch der Wahl eines Formates mit großen Abmessungen zu verdanken ist.

De vernieuwde smaak van grafsteenmaterialen uit zich in de collectie Prestigio: kostbare natuurlijke marmers uit de meest befaamde Italiaanse en Europese groeven worden gevaloriseerd door de typische kleurnuances en natuurlijke vlampatronen – soms delicaat en soms iets vuriger – die extra in het oog springen dankzij de glanzende polijstafwerking. Op die manier wordt de collectie de interpretatie van een klassieke stijl in een elegante moderne versie, mede dankzij de grote formaten.

El renovado gusto por los materiales lapídeos se pone de manifiesto con la colección Prestigio. Importantes mármoles naturales, procedentes de las mejores canteras italianas y europeas, se han propuesto para valorizar los típicos matices de color y las vetas originales, a veces delicadas y otras más marcadas, que destacan por un precioso acabado brillante. La colección se convierte así en una expresión del estilo clásico propuesta en clave moderna y elegante, gracias también a la elección de formatos de gran tamaño.

⚡ 6 mm

120x278/48"x110" Lucido R

⚡ 9 mm

120x240/48"x96" Lucido R

120x120/48"x48" Lucido R

60x120/24"x48" Lucido R

60x120/24"x48" Matt R

75x150/30"x60" Lucido R

75x150/30"x60" Soft R

75x75/30"x30" Lucido R

75x75/30"x30" Soft R

60x60/24"x24" Lucido R

60x60/24"x24" Soft R

30x60/12"x24" Lucido R

30x60/12"x24" Soft R



Gres porcellanato  
Porcelain stoneware  
Grès cérame fin vitrifié  
Feinsteinzeug  
Porseleingres  
Gres porcelánico



V2 Slight V3 Moderate \* V4 Substantial \*\*

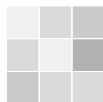
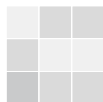

**Dolomite \***

75x150/30"x60" Lucido R	<b>MV75</b>
75x150/30"x60" Soft R	<b>MV76</b>
75x75/30"x30" Lucido R	<b>MV73</b>
75x75/30"x30" Soft R	<b>MV74</b>
60x60/24"x24" Lucido R	<b>MV77</b>
60x60/24"x24" Soft R	<b>MV78</b>
30x60/12"x24" Lucido R	<b>NH03</b>
30x60/12"x24" Soft R	<b>NE79</b>

**Carrara**

75x150/30"x60" Lucido R	<b>LU52</b>
75x150/30"x60" Soft R	<b>LU56</b>
75x75/30"x30" Lucido R	<b>LU90</b>
75x75/30"x30" Soft R	<b>LU99</b>
60x60/24"x24" Lucido R	<b>LU93</b>
60x60/24"x24" Soft R	<b>LV03</b>
30x60/12"x24" Lucido R	<b>NH02</b>
30x60/12"x24" Soft R	<b>NE80</b>



**Phantom \***

75x150/30"x60" Lucido R	<b>NL83</b>
75x150/30"x60" Soft R	<b>NL95</b>
75x75/30"x30" Lucido R	<b>NL86</b>
75x75/30"x30" Soft R	<b>NL92</b>
60x60/24"x24" Lucido R	<b>NL85</b>
60x60/24"x24" Soft R	<b>NL93</b>
30x60/12"x24" Lucido R	<b>NL84</b>
30x60/12"x24" Soft R	<b>NL94</b>



**Statuario \*\*** 120x278/48"x110" Lucido R **MK88**  
 120x240/48"x96" Lucido R **MP16**  
 120x120/48"x48" Lucido R **MP38**  
 60x120/24"x48" Lucido R **NS05**  
 60x120/24"x48" Matt R **NS09**  
 75x150/30"x60" Lucido R **LJ24**  
 75x150/30"x60" Soft R **MC72**  
 75x75/30"x30" Lucido R **LJ26**  
 75x75/30"x30" Soft R **MD88**  
 60x60/24"x24" Lucido R **LJ98**  
 60x60/24"x24" Soft R **MS14**  
 30x60/12"x24" Lucido R **NH08**  
 30x60/12"x24" Soft R **NE74**

**Calacatta \*\*** 120x278/48"x110" Lucido R **MK90**  
 120x240/48"x96" Lucido R **MP17**  
 120x120/48"x48" Lucido R **MP37**  
 60x120/24"x48" Lucido R **NS02**  
 60x120/24"x48" Matt R **NS07**  
 75x150/30"x60" Lucido R **MI16**  
 75x150/30"x60" Soft R **MU01**  
 75x75/30"x30" Lucido R **MI19**  
 75x75/30"x30" Soft R **MU00**  
 60x60/24"x24" Lucido R **MI22**  
 60x60/24"x24" Soft R **MI61**  
 30x60/12"x24" Lucido R **NH00**  
 30x60/12"x24" Soft R **NE81**

**Phantom 75x150/30"x60" Lucido R**



Fior di Bosco 75x75/30"x30" R Lucido



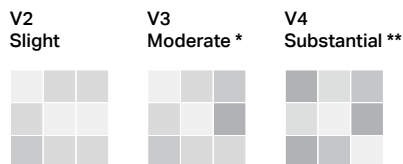

<b>Impero **</b>	120x278/48"x110" Lucido R	<b>MK91</b>
	120x240/48"x96" Lucido R	<b>MU10</b>
	120x120/48"x48" Lucido R	<b>MU08</b>
	60x120/24"x48" Lucido R	<b>NS03</b>
	60x120/24"x48" Matt R	<b>NP37</b>
	75x150/30"x60" Lucido R	<b>MS05</b>
	75x150/30"x60" Soft R	<b>MU02</b>
	75x75/30"x30" Lucido R	<b>MS06</b>
	75x75/30"x30" Soft R	<b>MU04</b>
	60x60/24"x24" Lucido R	<b>MS07</b>
	60x60/24"x24" Soft R	<b>MS11</b>
	30x60/12"x24" Lucido R	<b>NH04</b>
	30x60/12"x24" Soft R	<b>NE78</b>



<b>Tracia *</b>	75x150/30"x60" Lucido R	<b>LW45</b>
	75x75/30"x30" Lucido R	<b>LW48</b>
	60x60/24"x24" Lucido R	<b>LW49</b>
	60x60/24"x24" Soft R	<b>LW50</b>
	30x60/12"x24" Lucido R	<b>NH23</b>
	30x60/12"x24" Soft R	<b>NE73</b>



<b>Fior di Bosco *</b>	75x150/30"x60" Lucido R	<b>NL51</b>
	75x150/30"x60" Soft R	<b>NL55</b>
	75x75/30"x30" Lucido R	<b>NL50</b>
	75x75/30"x30" Soft R	<b>NL54</b>
	60x60/24"x24" Lucido R	<b>NL52</b>
	60x60/24"x24" Soft R	<b>NL56</b>
	30x60/12"x24" Lucido R	<b>NL53</b>
	30x60/12"x24" Soft R	<b>NL57</b>

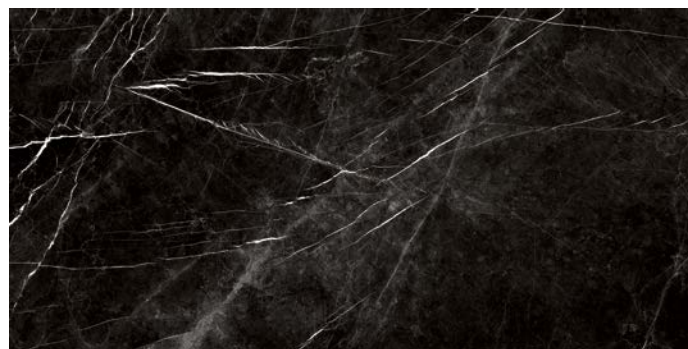

<b>Marquinia **</b>	120x278/48"x110" Lucido R	<b>MK89</b>
	120x240/48"x96" Lucido R	<b>MP15</b>
	120x120/48"x48" Lucido R	<b>MP36</b>
	60x120/24"x48" Lucido R	<b>NS04</b>
	60x120/24"x48" Matt R	<b>NS08</b>
	75x150/30"x60" Lucido R	<b>MI18</b>
	75x150/30"x60" Soft R	<b>MU03</b>
	75x75/30"x30" Lucido R	<b>MI21</b>
	75x75/30"x30" Soft R	<b>MU05</b>
	60x60/24"x24" Lucido R	<b>MI24</b>
	60x60/24"x24" Soft R	<b>MS12</b>
	30x60/12"x24" Lucido R	<b>NH06</b>
	30x60/12"x24" Soft R	<b>NE76</b>

Fondi/Plain Tiles/Fonds/  
Grundfliesen/Fondsen/Fondos

120x278/48"x110": Solo rivestimento/Wall coverings only/  
Uniquement pour une pose murale/ NurVerkleidung/  
Enkelwandbekleding/Sólo para el revestimiento

V2 Slight V3 Moderate \* V4 Substantial \*\*

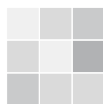
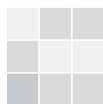

**Botticino \*** 75x150/30"x60" Lucido R **LX59**  
75x75/30"x30" Lucido R **LX60**  
60x60/24"x24" Lucido R **LX58**  
60x60/24"x24" Soft R **LX54**  
30x60/12"x24" Lucido R **NH01**  
30x60/12"x24" Soft R **NE82**



**Marfil \*** 75x150/30"x60" Lucido R **M117**  
75x75/30"x30" Lucido R **MI20**  
60x60/24"x24" Lucido R **MI23**  
60x60/24"x24" Soft R **MI62**  
30x60/12"x24" Lucido R **NH05**  
30x60/12"x24" Soft R **NE77**



**Travertino \*** 75x150/30"x60" Lucido R **LU54**  
75x75/30"x30" Lucido R **LU89**  
60x60/24"x24" Lucido R **LU94**  
60x60/24"x24" Soft R **LV04**  
30x60/12"x24" Lucido R **NH24**  
30x60/12"x24" Soft R **NE72**



**Arcadia \*** 120x278/48"x110" Lucido R **MK92**  
120x240/48"x96" Lucido R **MU09**  
120x120/48"x48" Lucido R **MU07**  
60x120/24"x48" Lucido R **NS01**  
60x120/24"x48" Matt R **NS06**  
75x150/30"x60" Lucido R **LU55**  
75x150/30"x60" Soft R **LU59**  
75x75/30"x30" Lucido R **LU87**  
75x75/30"x30" Soft R **LU97**  
60x60/24"x24" Lucido R **LU91**  
60x60/24"x24" Soft R **LV01**  
30x60/12"x24" Lucido R **NG99**  
30x60/12"x24" Soft R **NE83**



**Pulpis \*\*** 75x150/30"x60" Lucido R **LJ22**  
75x75/30"x30" Lucido R **LJ25**  
60x60/24"x24" Lucido R **LJ96**  
60x60/24"x24" Soft R **MS13**  
30x60/12"x24" Lucido R **NH07**  
30x60/12"x24" Soft R **NE75**

Per le indicazioni sull'utilizzo delle finiture Soft e Lucido vedere pagina 260/261.  
For indications on the use of the Soft and Lucido finishes, see page 260/261.  
Pour les indications sur l'utilisation des finitions Soft et Lucido, voir à la page 260/261.  
Für Hinweise zur Verwendung der Oberflächenausführungen Soft und Lucido siehe Seite 260/261.  
Voor aanwijzingen over het gebruik van de afwerkingen Soft en Lucido: zie 260/261.  
Para las indicaciones sobre la utilización de los acabados Soft y Lucido, ver la página 260/261.

Pulpis 75x75/30"x30" Lucido R

Prestigio  
244/245



Impero 120x120/48"x48" R Lucido — Marquinia Craquelé 120x278/48"x110" R Lucido





**Statuario Craquelé** 120x278/48"x110" Lucido R **ND45**



**Calacatta Craquelé** 120x278/48"x110" Lucido R **ND43**



**Marquinia Craquelé** 120x278/48"x110" Lucido R **NC49**



**Impero Craquelé** 120x278/48"x110" Lucido R **ND44**



**Arcadia Craquelé** 120x278/48"x110" Lucido R **ND42**



Statuario Mesh 120x278/48"x110" Lucido R





**Statuario** 120x278/48"x110" Lucido R **NB01**  
Mesh

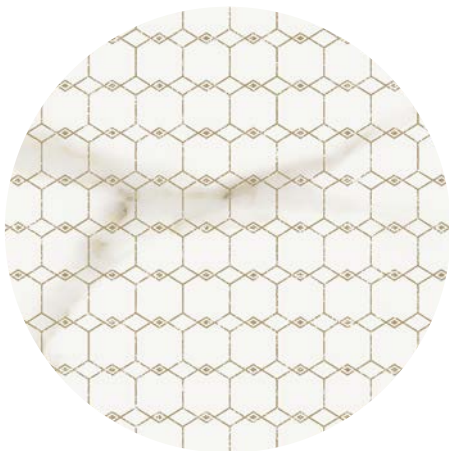

**Calacatta** 120x278/48"x110" Lucido R **NA98**  
Mesh

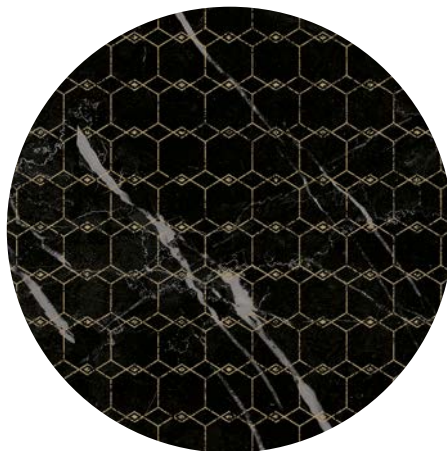

**Marquinia** 120x278/48"x110" Lucido R **NB00**  
Mesh



**Impero** 120x278/48"x110" Lucido R **NA99**  
Mesh



**Arcadia** 120x278/48"x110" Lucido R **NA97**  
Mesh

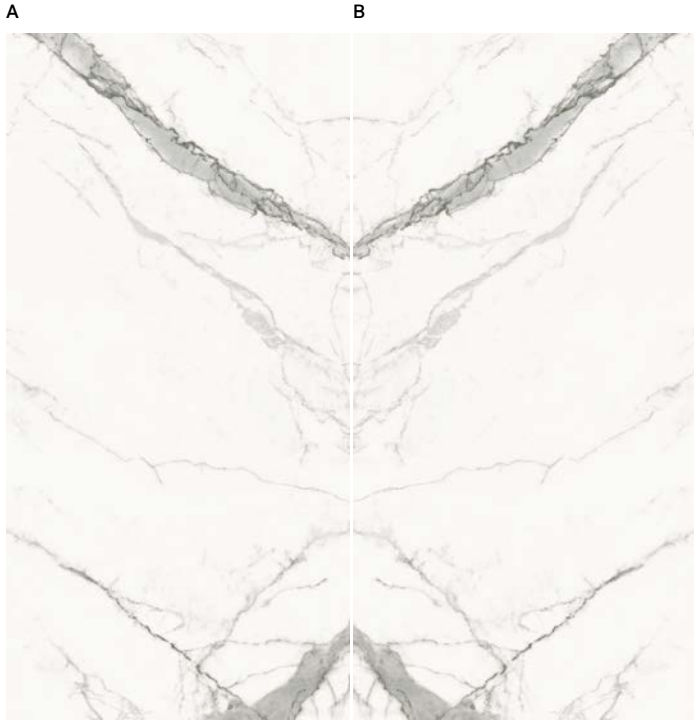

**Statuario Book-Match A** 75x150/30"x60" Lucido R  
**Statuario Book-Match B** 75x150/30"x60" Lucido R

**NL28**  
**NL29**

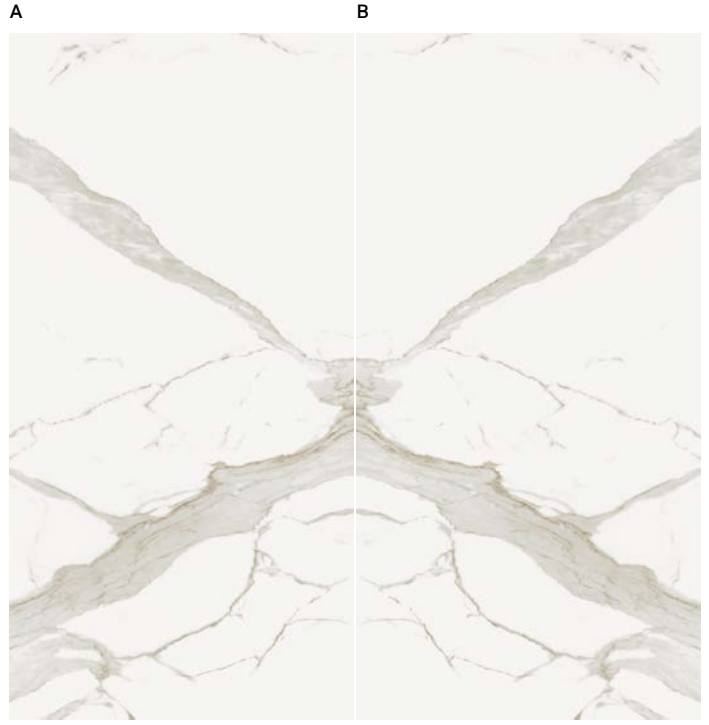

**Calacatta Book-Match A** 75x150/30"x60" Lucido R  
**Calacatta Book-Match B** 75x150/30"x60" Lucido R

**NL30**  
**NL31**





**Carrara 15x30/6"x12" Lucido R**  
Fascia Classic

MI04



**Statuario 15x30/6"x12" Lucido R**  
Fascia Classic

MI09

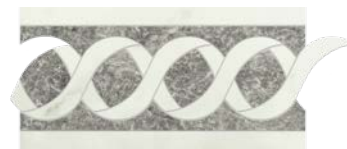

**Tracia 15x30/6"x12" Lucido R**  
Fascia Classic

LZ00



**Botticino 15x30/6"x12" Lucido R**  
Fascia Classic

LY98



**Arcadia 15x30/6"x12" Lucido R**  
Fascia Classic

LY97



**Pulpis 15x30/6"x12" Lucido R**  
Fascia Classic

LK22



**Fascia Classic Angolo Dx**

**Carrara 15x15/6"x6" Lucido R**  
**Statuario 15x15/6"x6" Lucido R**  
**Tracia 15x15/6"x6" Lucido R**  
**Botticino 15x15/6"x6" Lucido R**  
**Arcadia 15x15/6"x6" Lucido R**  
**Pulpis 15x15/6"x6" Lucido R**

MI06

MI11

LZ04

LZ02

LZ01

LK24



**Fascia Classic Angolo Sx**

**Carrara 15x15/6"x6" Lucido R**  
**Statuario 15x15/6"x6" Lucido R**  
**Tracia 15x15/6"x6" Lucido R**  
**Botticino 15x15/6"x6" Lucido R**  
**Arcadia 15x15/6"x6" Lucido R**  
**Pulpis 15x15/6"x6" Lucido R**

MI12

MI07

LZ08

LZ06

LZ05

LK26

**Decoro Carrara**  
è composto dal fondo Carrara e dall'inserto Marquinia.

**Decoro Statuario**  
è composto dal fondo Statuario e dall'inserto Marquinia.

**Decoro Botticino**  
è composto dal fondo Botticino e dall'inserto Arcadia.

**Decoro Arcadia**  
è composto dal fondo Arcadia e dall'inserto Botticino.

**Decoro Pulpis**  
è composto dal fondo Pulpis e dall'inserto Arcadia.

**Decoro Tracia**  
è composto dal fondo Tracia e dall'inserto Carrara.

**Carrara decoration**  
consists of the Carrara base and the Marquinia insert.

**Statuario decoration**  
consists of the Statuario base and Marquinia insert.

**Botticino decoration**  
consists of the Botticino base and Arcadia insert.

**Arcadia decoration**  
consists of the Arcadia base and Botticino insert.

**Pulpis decoration**  
consists of the Pulpis base and Arcadia insert.

**Tracia decoration**  
consists of the Tracia base and Carrara insert.

**Décor Carrara**  
est composé du fond Carrara et de l'insert Marquinia.

**Décor Statuario**  
est composé du fond Statuario et de l'insert Marquinia.

**Décor Botticino**  
est composé du fond Botticino et de l'insert Arcadia.

**Décor Arcadia**  
est composé du fond Arcadia et de l'insert Botticino.

**Décor Pulpis**  
est composé du fond Pulpis et de l'insert Arcadia.

**Décor Tracia**  
est composé du fond Tracia et de l'insert Carrara.

**Das Dekor Carrara**  
besteht aus dem Grundton Carrara und dem Einleger Marquinia.

**Das Dekor Statuario**  
besteht aus dem Grundton Statuario und dem Einleger Marquinia.

**Das Dekor Botticino**  
besteht aus dem Grundton Botticino und dem Einleger Arcadia.

**Das Dekor Arcadia**  
besteht aus dem Grundton Arcadia und dem Einleger Botticino.

**Das Dekor Pulpis**  
besteht aus dem Grundton Pulpis und dem Einleger Arcadia.

**Das Dekor Tracia**  
besteht aus dem Grundton Tracia und dem Einleger Carrara.

**De decoratietegel Carrara**  
bestaat uit een Carrara achtergrond met een Marquinia inzetstuk.

**De decoratietegel Statuario**  
bestaat uit een Statuario achtergrond met een Marquinia inzetstuk.

**De decoratietegel Botticino**  
bestaat uit een Botticino achtergrond met een Arcadia inzetstuk.

**De decoratietegel Arcadia**  
bestaat uit een Arcadia achtergrond met een Botticino inzetstuk.

**De decoratietegel Pulpis**  
bestaat uit een Pulpis achtergrond met een Arcadia inzetstuk.

**De decoratietegel Tracia**  
bestaat uit een Tracia achtergrond met een Carrara inzetstuk.

**La decoración Carrara**  
está caracterizada por el fondo Carrara y por la incrustación Marquinia.

**La decoración Statuario**  
está caracterizada por el fondo Statuario y por la incrustación Marquinia.

**La decoración Botticino**  
está caracterizada por el fondo Botticino y por la incrustación Arcadia.

**La decoración Arcadia**  
está caracterizada por el fondo Arcadia y por la incrustación Botticino.

**La decoración Pulpis**  
está caracterizada por el fondo Pulpis y por la incrustación Arcadia.

**La decoración Tracia**  
está caracterizada por el fondo Tracia y por la incrustación Carrara.



**Carrara 15x30/6"x12" Lucido R**  
Fascia Minimal

MI05



**Statuario 15x30/6"x12" Lucido R**  
Fascia Minimal

MI10



**Tracia 15x30/6"x12" Lucido R**  
Fascia Minimal

LZ12

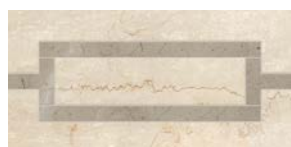

**Botticino 15x30/6"x12" Lucido R**  
Fascia Minimal

LZ10



**Arcadia 15x30/6"x12" Lucido R**  
Fascia Minimal

LZ09



**Pulpis 15x30/6"x12" Lucido R**  
Fascia Minimal

LK28

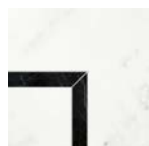

**Fascia Minimal Angolo**

<b>Carrara</b>	<b>15x15/6"x6" Lucido R</b>	<b>MI08</b>
<b>Statuario</b>	<b>15x15/6"x6" Lucido R</b>	<b>MI13</b>
<b>Tracia</b>	<b>15x15/6"x6" Lucido R</b>	<b>LZ16</b>
<b>Botticino</b>	<b>15x15/6"x6" Lucido R</b>	<b>LZ14</b>
<b>Arcadia</b>	<b>15x15/6"x6" Lucido R</b>	<b>LZ13</b>
<b>Pulpis</b>	<b>15x15/6"x6" Lucido R</b>	<b>LK30</b>

**Statuario Lucido 75x150/30"x60" R — Statuario Lucido 75x75/30"x30" R — Statuario Lucido 60x60/24"x24" R — Statuario Lucido Fascia Classic 15x30/6"x12" R — Statuario Lucido Fascia Classic Angolo Dx 15x15/6"x6" R — Statuario Lucido Fascia Classic Angolo Sx 15x15/6"x6" R**



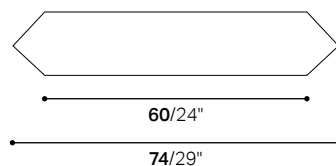

**Carrara Losanga** 14,5x74,5/6"x30" Lucido R NA94

**Impero Losanga** 14,5x74,5/6"x30" Lucido R NA95

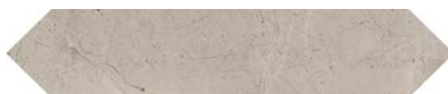

**Marquinia Losanga** 14,5x74,5/6"x30" Lucido R NA96

**Arcadia Losanga** 14,5x4,5/6"x30" Lucido R NA93

Marquinia 60x60/24"x24" Lucido R — Carrara Losanga 14,5x74,5/6"x30" Lucido R



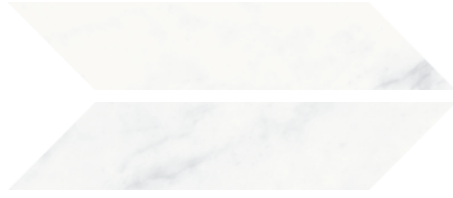
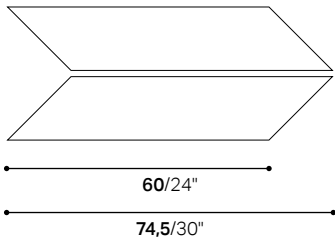

Carrara 14,5x60/6"x24" Lucido R NA25  
Chevron



Impero 14,5x60/6"x24" Lucido R NA26  
Chevron

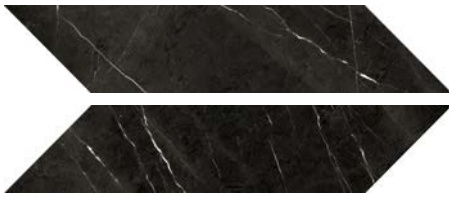

Marquinia 14,5x60/6"x24" Lucido R NA27  
Chevron



Arcadia 14,5x60/6"x24" Lucido R NA24  
Chevron

Marquinia Chevron 14,5x60/6"x24" Lucido R — Carrara Chevron 14,5x60/6"x24" Lucido R





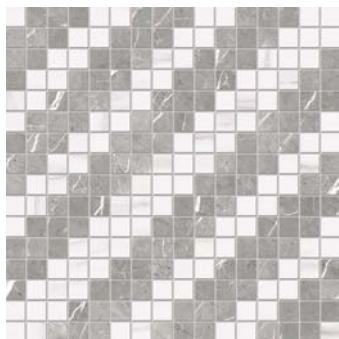

**Impero  
Lucido  
Mosaico  
Micro** 30x30/12"x12" R

NA36



**Marquinia  
Lucido  
Mosaico  
Micro** 30x30/12"x12" R

NA37

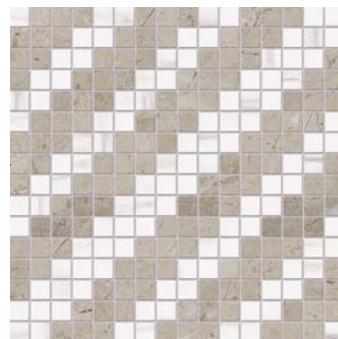

**Arcadia  
Lucido  
Mosaico  
Micro** 30x30/12"x12" R

NA35

**Arcadia Mosaico Micro 30x30/12"x12" Lucido R**



**Mosaico Micro Impero**  
è composto da Impero  
e Dolomite.

**Mosaico Micro Marquinia**  
è composto da Marquinia  
e Dolomite.

**Mosaico Micro Arcadia**  
è composto da Arcadia  
e Dolomite.

**Mosaico Micro Impero**  
consists of Impero  
and Dolomite.

**Mosaico Micro Marquinia**  
consists of Marquinia  
and Dolomite.

**Mosaico Micro Arcadia**  
consists of Arcadia  
and Dolomite.

**Mosaico Micro Impero**  
est composé du Impero  
et Dolomite.

**Mosaico Micro Marquinia**  
est composé du Marquinia  
et Dolomite.

**Mosaico Micro Arcadia**  
est composé du Arcadia  
et Dolomite.

**Mosaico Micro Impero**  
besteht asu dem Impero end  
dem Dolomite.

**Mosaico Micro Marquinia**  
besteht asu dem Marquinia end  
dem Dolomite.

**Mosaico Micro Arcadia**  
besteht asu dem Arcadia end  
dem Dolomite.

**Mosaico Micro Impero**  
bestaat uit een Impero met een  
Dolomite.

**Mosaico Micro Marquinia**  
bestaat uit een Marquinia met  
een Dolomite.

**Mosaico Micro Arcadia**  
bestaat uit een Arcadia met een  
Dolomite.

**Mosaico Micro Impero**  
está caracterizada por  
Impero y Dolomite.

**Mosaico Micro Marquinia**  
está caracterizada por  
Marquinia y Dolomite.

**Mosaico Micro Arcadia**  
está caracterizada por Arcadia  
y Dolomite.

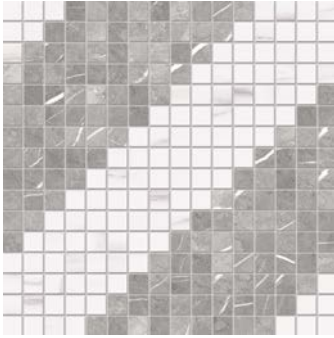

**Impero  
Lucido  
Mosaico  
Macro**     **30x30/12"x12" Lucido R**     **NA39**

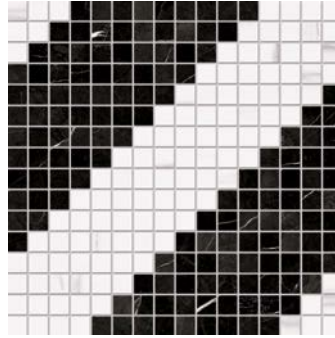

**Marquinia  
Lucido  
Mosaico  
Macro**     **30x30/12"x12" Lucido R**     **NA40**

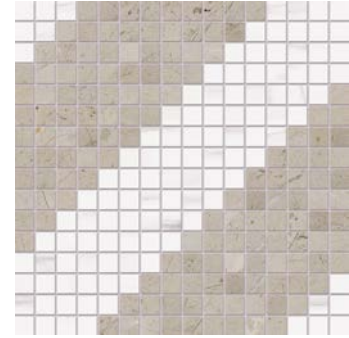

**Arcadia  
Lucido  
Mosaico  
Macro**     **30x30/12"x12" Lucido R**     **NA38**

**Impero Mosaico Macro 30x30/12"x12" Lucido R**



**Mosaico Micro Impero**  
è composto da Impero  
e Dolomite.

**Mosaico Micro Marquinia**  
è composto da Marquinia  
e Dolomite.

**Mosaico Micro Arcadia**  
è composto da Arcadia  
e Dolomite.

**Mosaico Micro Impero**  
consists of Impero  
and Dolomite.

**Mosaico Micro Marquinia**  
consists of Marquinia  
and Dolomite.

**Mosaico Micro Arcadia**  
consists of Arcadia  
and Dolomite.

**Mosaico Micro Impero**  
est composé du Impero  
et Dolomite.

**Mosaico Micro Marquinia**  
est composé du Marquinia  
et Dolomite.

**Mosaico Micro Arcadia**  
est composé du Arcadia  
et Dolomite.

**Mosaico Micro Impero**  
besteht aus dem Impero end  
dem Dolomite.

**Mosaico Micro Marquinia**  
besteht aus dem Marquinia end  
dem Dolomite.

**Mosaico Micro Arcadia**  
besteht aus dem Arcadia end  
dem Dolomite.

**Mosaico Micro Impero**  
bestaat uit een Impero met een  
Dolomite.

**Mosaico Micro Marquinia**  
bestaat uit een Marquinia met  
een Dolomite.

**Mosaico Micro Arcadia**  
bestaat uit een Arcadia met een  
Dolomite.

**Mosaico Micro Impero**  
está caracterizada por  
Impero y Dolomite.

**Mosaico Micro Marquinia**  
está caracterizada por  
Marquinia y Dolomite.

**Mosaico Micro Arcadia**  
está caracterizada por Arcadia  
y Dolomite.



V2 Slight      V3 Moderate \*      V4 Substantial \*\*



**Dolomite \*** 30x30/12"x12" R **MV84**  
Lucido  
Mosaico



**Carrara** 30x30/12"x12" R **LX39**  
Lucido  
Mosaico



**Phantom \*** 30x30/12"x12" R **NL91**  
Lucido  
Mosaico



**Statuario \*\*** 30x30/12"x12" R **LK05**  
Lucido  
Mosaico



**Calacatta \*\*** 30x30/12"x12" R **MI01**  
Lucido  
Mosaico

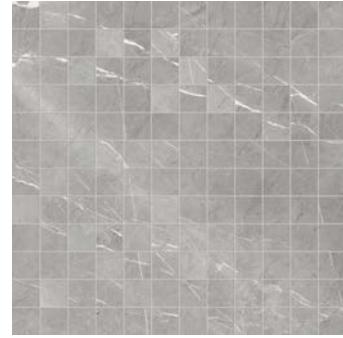

**Impero \*\*** 30x30/12"x12" R **MS15**  
Lucido  
Mosaico



**Tracia \*** 30x30/12"x12" R **LX40**  
Lucido  
Mosaico



**Fior di Bosco \*** 30x30/12"x12" R **NL49**  
Lucido  
Mosaico

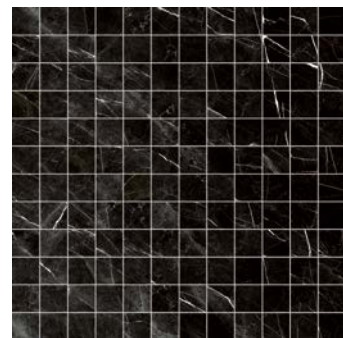

**Marquinia \*\*** 30x30/12"x12" R **MI03**  
Lucido  
Mosaico

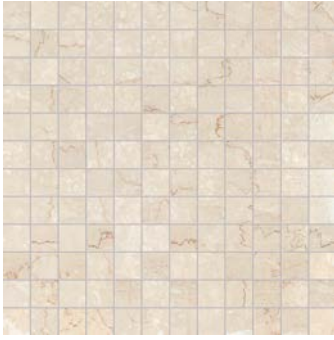

**Botticino \*** 30x30/12"x12" R LX42  
Lucido  
Mosaico

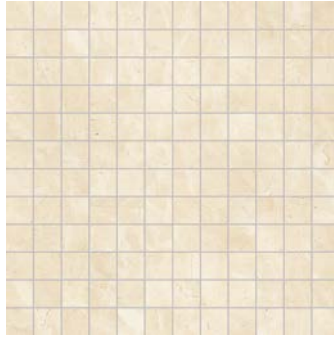

**Marfil \*** 30x30/12"x12" R MI02  
Lucido  
Mosaico



**Travertino \*** 30x30/12"x12" R LX41  
Lucido  
Mosaico



**Arcadia \*** 30x30/12"x12" R LX38  
Lucido  
Mosaico

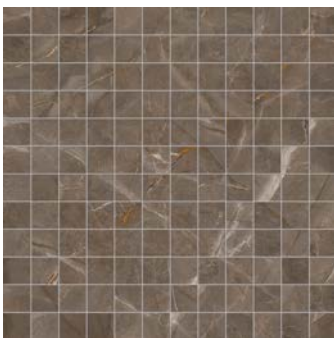

**Pulpis \*\*** 30x30/12"x12" R LK04  
Lucido  
Mosaico

**Carrara Lucido 75x150/30"x60" R — Carrara Lucido Mosaico 30x30/12"x12" R**



## Pezzi speciali/Trim tiles/Pieces speciales/Formteile/Speziale delen/Piezas especiales



### Battiscopa

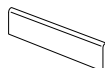

7x75/2<sup>7/8</sup>"x30" R

Arcadia Lucido	<b>LU65</b>
Botticino Lucido	<b>LX66</b>
Calacatta Lucido	<b>MH93</b>
Carrara Lucido	<b>LU62</b>
Dolomite Lucido	<b>MV80</b>
Fior di Bosco Lucido	<b>NL45</b>
Impero Lucido	<b>MS16</b>
Marfil Lucido	<b>MH94</b>
Marquinia Lucido	<b>MH95</b>
Phantom Lucido	<b>NL87</b>
Pulpis Lucido	<b>LK07</b>
Statuario Lucido	<b>LK08</b>
Tracia Lucido	<b>LW02</b>
Travertino Lucido	<b>LU64</b>
Arcadia Soft	<b>LU69</b>
Calacatta Soft	<b>MT95</b>
Carrara Soft	<b>LU66</b>
Dolomite Soft	<b>MV81</b>
Fior di Bosco Soft	<b>NL47</b>
Impero Soft	<b>MT96</b>
Phantom Soft	<b>NL90</b>
Marquinia Soft	<b>MT97</b>
Statuario Soft	<b>MT85</b>

7x60/2<sup>7/8</sup>"x24" R

Arcadia Lucido	<b>LV08</b>
Botticino Lucido	<b>LX67</b>
Calacatta Lucido	<b>MH96</b>
Carrara Lucido	<b>LV05</b>
Dolomite Lucido	<b>MV82</b>
Fior di Bosco Lucido	<b>NL46</b>
Impero Lucido	<b>MS17</b>
Marfil Lucido	<b>MH97</b>
Marquinia Lucido	<b>MH98</b>
Phantom Lucido	<b>NL88</b>
Pulpis Lucido	<b>LK10</b>
Statuario Lucido	<b>LK11</b>
Tracia Lucido	<b>LW04</b>
Travertino Lucido	<b>LV07</b>
Arcadia Soft	<b>LV12</b>
Botticino Soft	<b>LX69</b>
Calacatta Soft	<b>MH99</b>
Carrara Soft	<b>LV09</b>
Dolomite Soft	<b>MV83</b>
Fior di Bosco Soft	<b>NL48</b>
Impero Soft	<b>MS18</b>
Marfil Soft	<b>MI00</b>
Marquinia Soft	<b>MS19</b>
Phantom Soft	<b>NL89</b>
Pulpis Soft	<b>MS20</b>
Statuario Soft	<b>MS21</b>
Tracia Soft	<b>LW05</b>
Travertino Soft	<b>LV11</b>

## Caratteristiche/Features/Characteristiques/Eigenschaften/Eigenschappen/Características

### SOFT



UNI EN ISO 10545/14



B.C.R.A. Rep. CEC/81  
ANSI A 137.1-2012 (BOT3000)

Classe 5  
Class 5

Dry <0,40 / Wet > 0,40  
Wet >0,42

### MATT



UNI EN ISO 10545/14



DIN 51130

Classe 5  
Class 5

R10



B.C.R.A. Rep. CEC/81  
ANSI A 137.1-2012 (BOT3000)

Dry <0,40 / Wet > 0,40  
Wet >0,42

### LUCIDO



UNI EN ISO  
10545/7



UNI EN ISO 10545/14

Pb Cd

UNI EN ISO  
10545/15



B.C.R.A. Rep. CEC/81  
ANSI A 137.1-2012 (BOT3000)

PEI V (>12000 rev)  
Botticino, Calacatta, Carrara,  
Dolomite, Fior di Bosco, Marfil,  
Phantom

Conforme  
Compliant

Pb < 0,01 mg/dm<sup>2</sup>  
Cd < 0,001 mg/dm<sup>2</sup>

Non conforme / Failed  
Non conforme / Failed

PEI IV (12000 rev)  
Statuario, Travertino

PEI IV (6000 rev)  
Impero

PEI IV (2100 rev)  
Arcadia, Tracia

PEI III (750 rev)  
Marquinia, Pulpis

#### For USA, Canada and Oceania markets:

Prestigio SOFT finish is recommended for interior floors, walls, and exterior walls in both residential and commercial applications. Prestigio is not recommended for the exterior horizontal surfaces or exterior paving, and it is not recommended for ramps application. Prestigio SOFT finish is not recommended for interior floors in entrance areas if joined to outdoor in commercial applications. Prestigio LUCIDO is recommended for interior walls and exterior walls both in residential and commercial applications. Prestigio LUCIDO finish is not recommended for floors.

WARNING: THE LUCIDO (GLOSSY) FINISH DOES NOT MEET THE MINIMUM COEFFICIENT OF FRICTION, ACCORDING TO THE MOST RELEVANT NATIONAL STANDARDS FOR ANTISLIP RESISTANCE (AS PER EXAMPLE: ANSI 137.1-2012 / BOT3000; B.C.R.A. REP. CEC/81; DIN 51130; DIN 51097).

Imballi/Packing/Emballage/Verpackungseinheiten/Verpakking/Embalajes

	pcs x box	m <sup>2</sup> / m x box	kg x box	box x pallet	m <sup>2</sup> x pallet	kg x pallet
120x278/48"x96"	1	3,3360	49,56	18	60,05	892,08
120x240/48"x96"	1	2,8800	58,00	18	51,84	1044,00
120x120/48"x48"	2	2,8800	58,00	20	57,60	1160,00
60x120/24"x48" Lucido	2	1,4400	32,64	35	50,40	1142,40
60x120/24"x48" Matt	2	1,4400	31,50	35	50,40	1102,50
75x150/30"x60"	1	1,1250	24,50	25	28,13	612,50
75x75/30"x30"	2	1,1250	24,00	42	47,25	1008,00
60x60/24"x24"	3	1,0800	21,35	40	43,20	854,00
30x60/12"x24"	7	1,2600	25,00	40	50,40	1000,00
15x30/6"x12" Fascia Classic Lucido	4	0,1800	4,00	48	8,64	192,00
15x30/6"x12" Fascia Minimal Lucido	4	0,1800	4,00	48	8,64	192,00
15x15/6"x6" Fascia Classic Lucido Angolo Dx	4	0,0900	2,00	48	4,32	96,00
15x15/6"x6" Fascia Classic Lucido Angolo Sx	4	0,0900	2,00	48	4,32	96,00
15x15/6"x6" Fascia Minimal Lucido Angolo	4	0,0900	2,00	48	4,32	96,00
14,5x74,5/6"x30" Losanga Lucido	10	0,9750	22,00	21	20,48	462,00
14,5x60/6"x24" Chevron Lucido	12	1,0440	24,00	36	37,58	864,00
30x30/12"x12" Mosaico Micro Lucido	6	0,5400	10,20	36	19,44	367,20
30x30/12"x12" Mosaico Macro Lucido	6	0,5400	10,20	36	19,44	367,20
30x30/12"x12" Mosaico	11	0,9900	19,00	18	17,82	342,00
7x75/2 <sup>7/8</sup> "x30" Battiscopa	10	7,5000	11,00	54	405,00	594,00
7x60/2 <sup>7/8</sup> "x24" Battiscopa	10	6,0000	9,00	70	420,00	630,00

La finitura denominata Lucido può essere utilizzata per rivestimenti e pavimenti residenziali o comunque per superfici poco sollecitate, non a diretto contatto con aree esterne e dove non siano richieste prestazioni antiscivolo.  
 The Lucido (glossy) finish can be used for residential floors and walls, or other surfaces not subject to high traffic, not directly in contact with outdoor areas and where non-slip performance is not required.  
 La finition Lucido (brillant) peut être utilisée pour revêtir les murs et les sols des habitations ou des espaces soumis à un passage modéré auxquels l'accès n'est pas direct de l'extérieur et où aucune exigence particulière d'antiglissance ne doit être satisfaite.  
 Die Oberfläche Lucido (glanzpoliert) kann für Wandverkleidungen und Bodenbeläge in Wohnbereichen oder in anderen Bereichen mit geringer Trittbelastung verwendet werden, in denen es keinen direkten Zugang zu Außenbereichen gibt und für die keine rutschhemmenden Eigenschaften verlangt werden.  
 De afwerking Lucido (glans) kan worden gebruikt voor vloeren en wanden in huiselijke interieurs, voor oppervlakken die weinig worden betreden, die niet rechtstreeks in contact staan met zones buitenhuis en waar geen slipvaste kenmerken vereist worden.  
 El acabado denominado Lucido (brillante) puede emplearse para pared y pavimento residencial o en todo caso para superficies poco solicitadas, no tiene contacto directo con áreas externas donde no se requieran prestaciones antideslizantes.

I prodotti con le due finiture Soft e Lucido hanno calibri diversi e non sono pertanto abbinabili tra loro. L'azienda si riserva di valutare specifiche richieste di abbinamento. È sconsigliato l'abbinamento dei formati 120x240/48"x96" e 120x120/48"x48" con gli altri formati.  
 The products with the Soft and Lucido (glossy) finishes have different work sizes, and therefore cannot be used together: the company may take specific combination requests into consideration. It is not recommended to match the 120x240/48"x96" and 120x120/48"x48" sizes with the other sizes.  
 Les produits qui présentent les deux finitions de surface Soft et Lucido (brillant) ont des calibres différents. C'est pourquoi ils n'est pas possible de les associer l'un à l'autre. Notre entreprise se réserve d'examiner toute demande d'association spécifique. Il est déconseillé d'assortir les formats 120x240/48"x96" et 120x120/48"x48" aux autres formats.  
 Die Produkte mit den Oberflächenausführungen Soft und Lucido (Glänzend) haben verschiedene Werkmaße und können daher nicht miteinander kombiniert werden. Die Firma behält sich das Recht vor, spezielle Kombinationsanfragen abzuwägen. Es wird von der Kombination der Formate 120x240/48"x96" und 120x120/48"x48" mit den anderen Formaten abgeraten.  
 De producten met afwerkingen Soft en Lucido (glanzend) hebben verschillende diktes en zijn derhalve niet combineerbaar met elkaar. Het bedrijf zal de specifieke verzoeken voor tegelcombinatie geval per geval evalueren. Het wordt afgeraden om de formaten 120x240/48"x96" en 120x120/48"x48" met andere formaten te combineren.  
 Los productos con los dos acabados Soft y Lucido (brillante) tienen diferentes calibres y, por lo tanto, no se pueden combinar entre sí. La empresa se reserva el derecho de evaluar las solicitudes de combinación específicas. Se aconseja combinar los formatos 120x240/48"x96" y 120x120/48"x48" con los otros formatos.

Chiaro 90x90/36"x36" R OUT2.0



## Open-air experience

Risseu è una collezione di piastrelle in gres porcellanato ispirata ai tipici pavimenti acciottolati che tradizionalmente decorano le pavimentazioni dei sagrati e dei giardini urbani della città di Genova. La tridimensionalità, già evidente come effetto grafico, risulta ulteriormente accentuata dalla perfetta combinazione con la lieve struttura a rilievo, che ricrea sulla superficie l'effetto reale dei ciottoli. La collezione, dal forte impatto visivo, è proposta nella variante per esterni OUT2.0 ed anche nell'inaspettata versione per utilizzo in interno, soluzione che permette di creare inedite pavimentazioni effetto ciottolato anche in ambienti indoor.

Risseu is a collection of porcelain stoneware tiles inspired by traditional cobbled paving in courtyards and urban gardens of the city of Genoa (Italy). The three-dimensionality – already evident as a graphic effect – is further accentuated by perfect combination with the slight relief that recreates the real effect of a cobbled surface. The collection is offered in the OUT2.0 outdoor version with a strong visual impact and also in an unexpected indoor version, a solution that allows you to create original cobblestone effects even in indoor environments.

Risseu est une collection de carreaux en grès cérame inspirée des sols pavés typiques, qui décorent traditionnellement les pavages des parvis et des jardins urbains de la ville de Gène (Italie). La tridimensionnalité déjà évidente comme effet graphique, est encore mieux mise en évidence par la combinaison parfaite avec la structure légère en relief, qui recrée l'effet réel des galets. La collection, à l'impact visuel fort, est proposée dans la variante d'extérieur OUT2.0 et dans la version d'intérieur, solution qui permet de créer des pavages inédits à l'effet de pavé même dans des environnements indoor.

Risseu ist eine Kollektion aus Feinsteinzeugfliesen, die das traditionelle, charakteristische Pflaster von Kirchplätzen und städtischen Parks in Genua nachempfunden. Die bereits als grafischer Effekt deutliche Dreidimensionalität wird durch die perfekte Kombination mit der leichten Reliefstruktur, die die echten Pflastersteine realistisch auf der Oberfläche des Feinsteinzeugs reproduziert, noch weiter unterstrichen. Die optisch ausgesprochen effektvolle Kollektion wird in der Variante für Außenbereiche OUT2.0 angeboten, und dazu auch in der innovativen Indoor-Version, dank der auch Innenräume mit dieser originellen Pflaster-Optik gestaltet werden können.

Risseu is een collectie gres porcellanato-tegels, die geïnspireerd is op de kenmerkende kasseibestrating die traditiegetrouw is gebruikt voor de ruimtes voor de kerk en de stadstuinen van de stad Genua. De driedimensionaliteit, die al zichtbaar is als grafisch effect, wordt verder geaccentueerd door de perfecte combinatie met de lichte reliëfstructuur, die het echte effect van de kasseien op het oppervlak nabootst. De collectie, met zijn sterke visuele impact, is verkrijgbaar in de outdoor versie OUT2.0 en ook in de onverwachte versie voor gebruik binnenshuis, waardoor het mogelijk wordt om een nieuwe vloer met het effect van kasseien te creëren, zelfs in een binnenshuis.

Risseu es una colección de azulejos de gres porcelánico inspirada en los típicos suelos empedrados que tradicionalmente decoran los suelos de las fiestas y los jardines urbanos de la ciudad de Génova (Italia). La tridimensionalidad, ya evidente como efecto gráfico, se acentúa aún más por la perfecta combinación con la ligera estructura de relieve, que recrea el efecto real de los guijarros en la superficie. La colección, con su fuerte impacto visual, se propone en la versión para exteriores OUT2.0 y también en la versión inesperada para uso en interiores, una solución que permite crear nuevos suelos de efecto empedrado incluso en ambientes interiores.

✂ 9 mm

60x60/24"x24" R

✂ 20 mm

90x90/36"x36" R OUT2.0



V2  
Slight



**Chiaro**    **60x60/24"x24" R**    **NS10**  
**90x90/36"x36" R OUT2.0**    **NQ24**



**Scuvo**    **60x60/24"x24" R**    **NS11**  
**90x90/36"x36" R OUT2.0**    **NQ25**

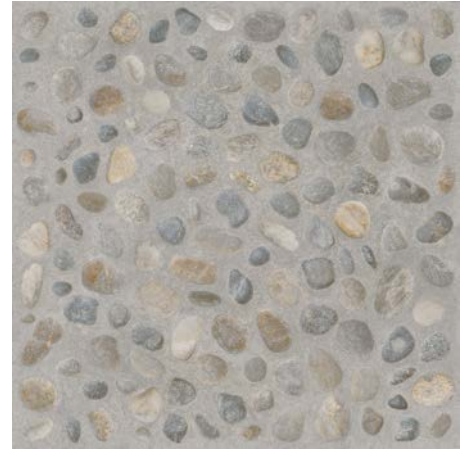

**Multicolor**    **60x60/24"x24" R**    **NU20**

Scuro 60x60/24"x24" R

Risseu  
264/265



## Imballi/Packing/Emballage/Verpackungseinheiten/Verpakking/Embalajes

	pcs x box	m <sup>2</sup> / m x box	kg x box	box x pallet	m <sup>2</sup> x pallet	kg x pallet
60x60/24"x24"	3	1,0800	21,35	40	43,20	854,00
90x90/36"x36" <b>OUT2.0</b>	1	0,8100	37,60	18	14,58	676,80

### Scuro 90x90/36"x36" R OUT2.0



## Caratteristiche/Features/Caracteristiques/Eigenschaften/Eigenschappen/Características



UNI EN ISO 10545/14

Classe 5 / Class 5



DIN 51130

R10  
R11 OUT2.0



BC.R.A. Rep. CEC/81

Asciutto > 0,40 / Bagnato > 0,40



ANSI A137.1-2012 (BOT3000)

> 0,42 Wet

Chiaro 60x60/24"x24" R





# Stardust

# 268/269

## Sparkling atmosphere

I contrasti e la luminosità del cielo stellato diventano l'ispirazione per una superficie che accoglie e riflette delicatamente la luce: le venature tono su tono e i riflessi metallescenti enfatizzano l'eleganza di un materiale inedito e attuale. Grazie alla suggestione creata dai passaggi di tono e dalle sfumature cangianti, Stardust caratterizza ambienti moderni e dalla forte personalità.

The contrasts and brightness of a starlit sky become the inspiring concept of a surface that welcomes and gently reflects light: the ton-sur-ton vein patterns and metal-flake reflections emphasise the elegance of an unprecedented and trendy material. Thanks to the charm created by the change in tone and by the iridescent shades, Stardust distinguishes modern settings with a strong personality.

Les contrastes et la luminosité du ciel étoilé: telle est l'inspiration pour une surface qui accueille et reflète délicatement la lumière. Les veines tons sur tons et les reflets métallescents mettent en valeur l'élégance d'un matériau inédit et actuel. Grâce à l'effet pittoresque créé par les passages de tons et par les nuances changeantes, Stardust donne du cachet aux pièces modernes à forte personnalité.

Die Kontraste und die Helligkeit des Sternenhimmels werden zur Inspiration für eine Oberfläche, die das Licht empfängt und sanft reflektiert: Die Ton-in-Ton-Aderungen und die metallisierenden Schimmer unterstreichen die Eleganz eines neuen und modernen Materials. Dank der Suggestion, die durch die Veränderungen von Ton und irisierenden Nuancen entsteht, charakterisiert Stardust moderne Umgebungen mit einer starken Persönlichkeit.

De contrasten en schittering van de sterrenhemel dienden als inspiratie voor een oppervlak dat het licht fijngevoelig ontvangt en reflecteert: de ton-sur-ton aderingen en de metaalachtige weerkaatsingen benadrukken de elegantie van een geheel nieuw, eigentijds materiaal. Dankzij de suggestie die ontstaat uit kleurovergangen en glanzende nuances, kenmerkt Stardust moderne ruimten met een sterke persoonlijkheid.

Los contrastes y la luminosidad del cielo estrellado sirven de inspiración para crear una superficie que recoge y refleja la luz con delicadeza. Las vetas tono sobre tono y los reflejos metálicos exaltan la elegancia de un material inédito y actual. Gracias al hechizo que produce la transición de tonos y los matices cambiantes, Stardust otorga carácter a los ambientes modernos y de gran personalidad.

9 mm

75x150/30"x60" Soft R  
75x75/30"x30" Soft R  
60x120/24"x48" Soft R  
60x60/24"x24" R  
60x60/24"x24" Soft R  
30x60/12"x24" R  
30x60/12"x24" Soft R

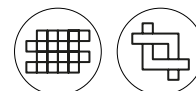

Gres porcellanato  
Porcelain stoneware  
Grès cérame fin vitrifié  
Feinsteinzeug  
Porseleingres  
Gres porcelánico

V4  
Substantial



**Milk**

75x150/30"x60" Soft R	<b>MK07</b>
75x75/30"x30" Soft R	<b>NA78</b>
60x120/24"x48" Soft R	<b>ND49</b>
60x60/24"x24" R	<b>NC00</b>
60x60/24"x24" Soft R	<b>NC01</b>
30x60/12"x24" R	<b>NC74</b>
30x60/12"x24" Soft R	<b>NC75</b>



**Moon**

75x150/30"x60" Soft R	<b>MK09</b>
75x75/30"x30" Soft R	<b>NA80</b>
60x120/24"x48" Soft R	<b>ND50</b>
60x60/24"x24" R	<b>NC02</b>
60x60/24"x24" Soft R	<b>NC03</b>
30x60/12"x24" R	<b>NC76</b>
30x60/12"x24" Soft R	<b>NC77</b>



**Nebula**

75x150/30"x60" Soft R	<b>MK05</b>
75x75/30"x30" Soft R	<b>NA82</b>
60x120/24"x48" Soft R	<b>ND51</b>
60x60/24"x24" R	<b>NC04</b>
60x60/24"x24" Soft R	<b>NC05</b>
30x60/12"x24" R	<b>NC78</b>
30x60/12"x24" Soft R	<b>NC79</b>

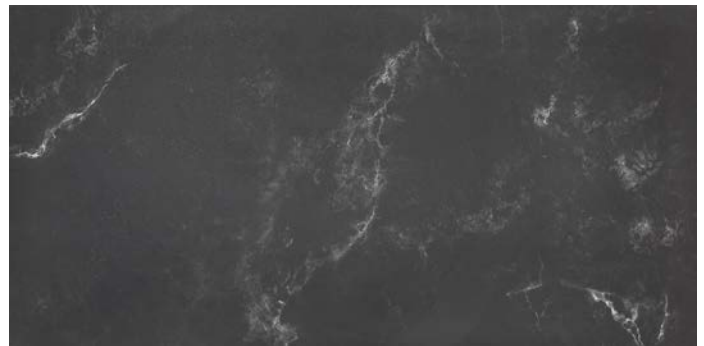

**Deep**

75x150/30"x60" Soft R	<b>MK03</b>
75x75/30"x30" Soft R	<b>NA76</b>
60x120/24"x48" Soft R	<b>ND48</b>
60x60/24"x24" R	<b>NC06</b>
60x60/24"x24" Soft R	<b>NC07</b>
30x60/12"x24" R	<b>NC72</b>
30x60/12"x24" Soft R	<b>NC73</b>







V4  
Substantial

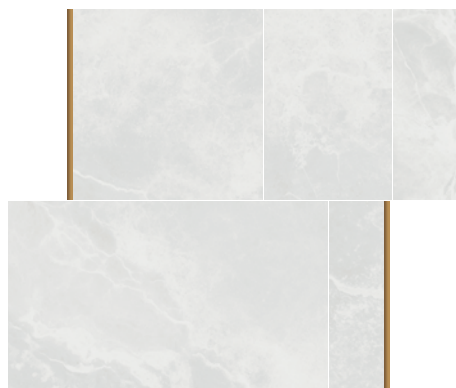

**Milk** 37,5x37,5/15"x15" Soft R **NA46**  
**Mosaico**

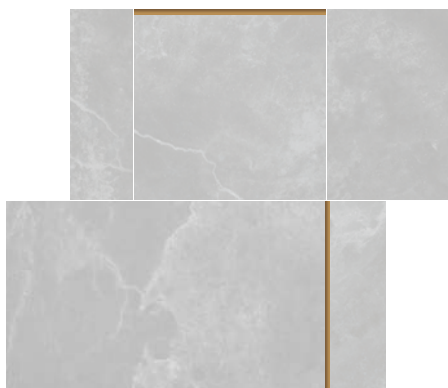

**Moon** 37,5x37,5/15"x15" Soft R **NA47**  
**Mosaico**

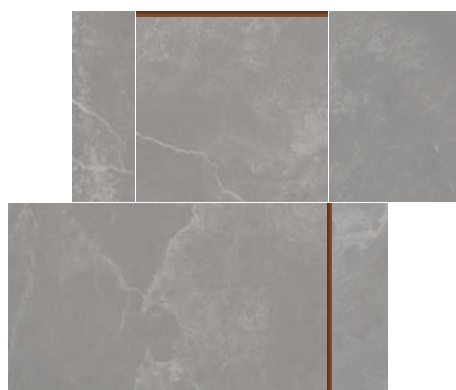

**Nebula** 37,5x37,5/15"x15" Soft R **NA48**  
**Mosaico**

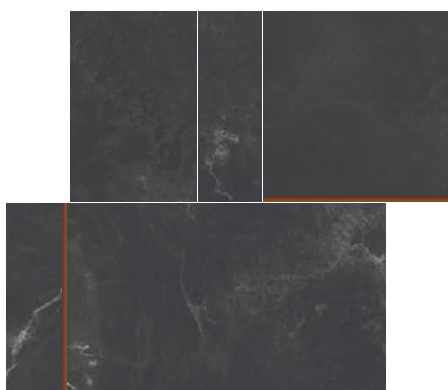

**Deep** 37,5x37,5/15"x15" Soft R **NA45**  
**Mosaico**

**Bacchetta** 0,5x18,5/1/4"x7<sup>1/4</sup>" **NB39**  
**Oro**

**Bacchetta** 0,5x18,5/1/4"x7<sup>1/4</sup>" **NB38**  
**Bronzo**

**Bacchetta** 0,5x18,5/1/4"x7<sup>1/4</sup>" **NB80**  
**Argento**

Elemento necessario per il completamento del Mosaico disponibile nei colori Argento, Bronzo e Oro./Element necessary for the completion of the Mosaico available in Argento (Silver), Bronzo (Bronze) and Oro (Gold) colours./Élément nécessaire pour compléter la Mosaïque disponible dans les coloris Argento (Argent), Bronzo (Bronze) et Or (Oro)./Dieses Element ist in Argento (Silber), Bronzo (Bronze) und Oro (Gold) erhältlich und dient für die vervollständigung des Mosaiks./Element dat nodig is ter vervollediging van het mozaïek, leverbaar in de kleuren Argento (Zilver), Bronzo (Bronz) en Oro (Goud)./Elemento necesario para completar el Mosaico disponible en colores Argento, (Plata), Bronzo (Bronce) y Oro (Oro).

1 box Mosaico = 1 box Bacchetta

**Bacchetta** 0,5x75/1/4"x30" **NB37**  
**Oro**

**Bacchetta** 0,5x75/1/4"x30" **NB36**  
**Bronzo**

**Bacchetta** 0,5x75/1/4"x30" **NL39**  
**Argento**

Listello decorativo opzionale per rivestimenti (non utilizzabile come terminale)./Optional decorative strip for claddings (cannot be used as an end piece)./Listel décoratif en option pour revêtements (non utilisable comme profilé de finition)./Optionaler Zierriemen für die Wand (kann nicht als Abschluss verwendet werden)./Optionele sierlijst voor wandtegels (niet bruikbaar als eindstuk)./Franja decorativa opcional para revestimientos (no utilizable como remate).

Milk Mosaico 37,5x75/15"x30" Soft R — Bacchetta Bronzo 0,5x18,5/1/4"x7<sup>1/4</sup>"

Stardust  
272/273



## Pezzi speciali/Trim tiles/Pieces speciales/Formteile/Speciale delen/Piezas especiales

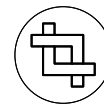

### Battiscopa



7x75/2<sup>7/8</sup>"x30" R

Deep **MK38**  
Milk **MK40**  
Moon **MK41**  
Nebula **MK39**

7x60/2<sup>7/8</sup>"x24" R

Deep **NC66**  
Milk **NC67**  
Moon **NC68**  
Nebula **NC69**

## Imballi/Packing/Emballage/Verpackungseinheiten/Verpakking/Embalajes

	pcs x box	m <sup>2</sup> / m x box	kg x box	box x pallet	m <sup>2</sup> x pallet	kg x pallet
75x150/30"x60"	1	1,1250	24,50	25	28,13	612,50
75x75/30"x30"	2	1,1250	24,00	42	47,25	1008,00
60x120/24"x48"	2	1,4400	31,50	35	50,40	1102,50
60x60/24"x24"	3	1,0800	21,35	40	43,20	854,00
30x60/12"x24"	7	1,2600	25,00	40	50,40	1000,00
37,5x37,5/15"x30" Mosaico	6	0,8437	11,40	24	20,25	273,60
0,5x75/1/4"x30" Bacchetta	10	7,5000	1,03	506		
0,5x18,5/1/4"x7 <sup>1/4</sup> " Bacchetta	12	2,2200	0,31	720		
7x75/2 <sup>7/8</sup> "x30" Battiscopa	10	7,5000	11,00	54	405,00	594,00
7x60/2 <sup>7/8</sup> "x24" Battiscopa	10	6,0000	9,00	70	420,00	630,00

The MATT and SOFT finishes are recommended for interior floors, walls, and exterior walls in both residential and commercial applications. Stardust is not recommended for exterior horizontal surfaces or exterior paving, and they are not recommended for ramps application. The SOFT finish is not recommended for interior floors in entrance areas if joined to outdoor in commercial applications.

## SOFT Caratteristiche/Features/Caracteristiques/Eigenschaften/Eigenschappen/Características



UNI EN ISO 10545/14

Classe 5 / Class 5



B.C.R.A. Rep. CEC/81

Asciutto > 0,40 / Bagnato > 0,40



ANSI A137.1-2012 (BOT3000)

> 0,42 Wet

## MATT Caratteristiche/Features/Caracteristiques/Eigenschaften/Eigenschappen/Características



UNI EN ISO 10545/14

Classe 5 / Class 5



DIN 51130

R10



BS 7976-2:2002  
(CEN/TS 16165, Annex C)  
Pendulum Friction Test

≥ 36 Wet



B.C.R.A. Rep. CEC/81

Asciutto > 0,40 / Bagnato > 0,40

ANSI A137.1-2012 (BOT3000)

> 0,42 Wet

Moon 75x150/30"x60" Soft R

Stardust  
274/275



Natural 15x75/6"x30" R



## Natural emotion

Il legno di quercia, storicamente utilizzato per la costruzione di arredi, infissi e pavimentazioni, in ambito navale e per l'invecchiamento dei grandi vini, si ritrova nella collezione Trail: con le sue fibre dritte dai pochi nodi, che permettono varie tipologie di posa, l'essenza trasmette il suo valore nobile di resistenza e durabilità restituendo sensazioni calde e naturali sia in situazioni domestiche che collettive.

Oak wood is historically used to build furniture, shutters and floors, in naval construction works and casks for ageing wine, and is brought up to date in the Trail collection: with straight fibres and few knots, this noble wood renowned for its strength and durability can be used in a range of laying patterns, offering warm, natural sensations in both residential and public settings.

Le bois de chêne qui, depuis la nuit des temps, a été utilisé pour la fabrication de meubles, d'huisseries et de parquets, aussi bien sur les chantiers navals que pour donner asile au repos des grands crus, se retrouve dans la collection Trail. Avec ses fibres droites, rarement interrompues de nœuds, qui permettent une grande variété de calepinages, cette essence transmet sa noble réputation de solidité et de durabilité en donnant des sensations chaudes et naturelles aussi bien dans des contextes domestiques que collectifs.

Eichenholz wurde früher für den Bau von Möbeln, Tür- und Fensterrahmen und für Bodenbeläge verwendet. Auch im Schiffbau und für Weinfässer kam es zur Anwendung, und hier finden wir es in der Kollektion Trail wieder, mit gerade verlaufenden Holzfasern und wenigen Astlöchern, was verschiedene Verlegeformen zulässt. Dieses Edelholz verkörpert Beständigkeit und Haltbarkeit und verleiht ein gemütliches und gleichzeitig natürliches Flair für Wohnungen und den Objektbereich.

Eikenhout, in het verleden gebruikt voor kasten, ramen en vloeren, in de scheepsbouw en voor rijping van prestigieuze wijnen, vind je nu terug in de collectie Trail, die met zijn rechte vezels en geringe knopen geschikt is voor uiteenlopende plaatsingspatronen. De essentie, die een edel en duurzaam karakter uitstraalt, creëert een warme en natuurlijke sfeer en is geschikt voor zowel huiselijke als openbare omgevingen.

La madera de roble, históricamente utilizada para la construcción de muebles, accesorios y pavimento, en ámbito naval y para el envejecimiento de grandes vinos, se reúne en la colección Trail: con sus fibras rectas de pocos nudos, que permiten varias tipologías de colocación, la esencia transmite su noble valor de resistencia y durabilidad devolviendo sensaciones cálidas y naturales ya sea en contexto doméstico como colectivo.

9 mm

15x75/6"x30" R

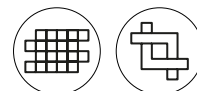

Gres porcellanato  
Porcelain stoneware  
Grès cérame fin vitrifié  
Feinsteinzeug  
Porseleingres  
Gres porcelánico

V2  
Slight



Clear 15x75/6"x30" R LC85



Mud 15x75/6"x30" R LC89



Musk 15x75/6"x30" R LC90



Cool 15x75/6"x30" R LC86



Crude      15x75/6"x30" R      LC87



Natural      15x75/6"x30" R      LC91



Chrono      15x75/6"x30" R      LC84



Dark      15x75/6"x30" R      LC88





V2  
Slight



Clear Muretto Listello 25x75/10"x30" R LF56



Mud Muretto Listello 25x75/10"x30" R LF61



Musk Muretto Listello 25x75/10"x30" R LF62

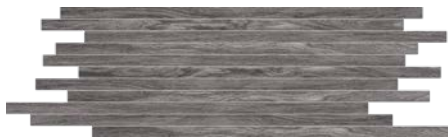

Cool Muretto Listello 25x75/10"x30" R LF58



Crude Muretto Listello 25x75/10"x30" R LF59



Natural Muretto Listello 25x75/10"x30" R LF63

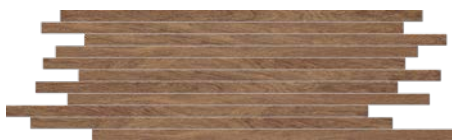

Chrono Muretto Listello 25x75/10"x30" R LF57



Dark Muretto Listello 25x75/10"x30" R LF60

Pezzi speciali/Trim tiles/Pieces speciales/Formteile/Speciale delen/Piezas especiales



Battiscopa

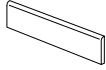

7x75/27<sup>8</sup> x30" R

Chrono	LD32
Clear	LD31
Cool	LD33
Crude	LD34
Dark	LD35
Mud	LD36
Musk	LD37
Natural	LD38

Imballi/Packing/Emballage/Verpackungseinheiten/Verpakking/Embalajes

	pcs x box	m <sup>2</sup> / m x box	kg x box	box x pallet	m <sup>2</sup> x pallet	kg x pallet
15x75/6"x30"	7	0,7875	17,50	48	37,80	840,00
25x75/10"x30" Muretto Listello	4	0,7500	16,00	24	18,00	384,00
7x75/27 <sup>8</sup> x30" Battiscopa	10	7,5000	11,00	54	405,00	594,00

Clear 15x75/6"x30" R



Caratteristiche/Features/Caracteristiques/Eigenschaften/Eigenshappen/Características



UNI EN ISO 10545/14

Classe 5 / Class 5



DIN 51130

R10



BS 7976-2:2002  
(CEN/TS 16165, Annex C)  
Pendulum Friction Test

≥ 36 Wet



B.C.R.A. Rep. CEC/81

Asciutto > 0,40 / Bagnato > 0,40



ANSI A137.1-2012 (BOT3000)

> 0,42 Wet

Rock 120x120/48"x48" Soft R - 60x120/24"x48" Soft R - 60x60/24"x24" Soft R - 30x60/12"x24" Soft R



## Natural swing

Un'inedita combinazione di materiali lapidei provenienti da diverse aree del nord Europa, selezionati e miscelati per creare originali pattern e sfumature. Delicate venature, piccoli grani e superfici sabbiose si fondono nella collezione Tune, disponibile in formati di grandi e medie dimensioni che esaltano l'equilibrio delle superfici e consentono di vestire con eleganza ogni tipologia di ambiente: 120x120, 60x120, 60x60, 30x60 e la versione per esterno OUT2.0. La palette naturale, nelle tinte Snow, Rock, Lava e Desert, è completata da tre diverse tipologie di mosaici: il Muretto 3D, caratterizzato da scanalature inclinate, il Mosaico Linea, composto da listelli orizzontali di diverse altezze, e il Mosaico, che racchiude tessere quadrate e rettangolari, dalle dimensioni irregolari.

An unprecedented combination of stone materials originating from various areas in Northern Europe, picked and mixed to create original patterns and shades. Delicate vein patterns, small grains and sandy surfaces merge together in the Tune collection, which is available in both large and medium sizes, to enhance the balance of the surfaces and to clad all settings with elegance: 120x120, 60x120, 60x60, 30x60 and the outdoor version, OUT2.0. The natural palette, in Snow, Rock, Lava and Desert colours, is completed by three different types of mosaics: Muretto 3D, which stands out for its slanted grooves, Mosaico Linea, which consists of horizontal strips of various heights, and Mosaico, which encapsulates square and rectangular mosaic tiles with irregular dimensions.

Une combinaison inédite de matériaux en pierre provenant de différentes régions d'Europe du Nord, sélectionnés et mélangés pour créer des motifs et des nuances originaux. Veines délicates, petits grains et surfaces sableuses se fondent dans la collection Tune, disponible en formats de grandes et moyennes dimensions, mettant en valeur l'équilibre des surfaces et permettant de parer avec élégance n'importe quel type d'environnement : 120x120, 60x120, 60x60, 30x60 et la version pour extérieur OUT2.0. La palette naturelle, dans les teintes Snow, Rock, Lava et Desert, est complétée par trois différents types de mosaïques: le Muretto 3D, caractérisé par des rainures inclinées, le Mosaico Linea, composé de lattes horizontales de différentes hauteurs, et le Mosaico, qui comprend des morceaux carrés et rectangulaires aux dimensions irrégulières.

Eine ungewöhnliche Kombination von Steinmaterialien aus verschiedenen Gebieten Nordeuropas, die sorgfältig ausgewählt und zusammengestellt wurden, um originale Muster und Nuancen zu bilden. Zarte Äderungen, kleine Maserungen und sandige Oberflächen verschmelzen in der Tune Kollektion, die in großen und mittleren Formaten erhältlich ist, um das Gleichgewicht der Oberflächen hervorzuheben und jedes Ambiente elegant zu gestalten: 120x120, 60x120, 60x60, 30x60 und OUT2.0 für den Außenbereich. Die natürliche Farbenpalette umfasst Snow, Rock, Lava und Desert, und wird mit drei verschiedenen Mosaik-Typologien abgerundet: Muretto 3D, mit schrägen Rillen, Mosaico Linea, mit horizontalen Riemen in verschiedenen Höhen und Mosaico mit quadratischen und rechteckigen Steinen in unregelmäßigen Abmessungen.

Een geheel nieuwe combinatie van natuursteenmaterialen afkomstig uit diverse gebieden in Noord-Europa, speciaal gekozen en samengevoegd tot originele patronen en nuances. Fijne aders, kleine korrels en zandige oppervlakken smelten samen in de collectie Tune, leverbaar in grote en middelgrote formaten die het evenwicht van de oppervlakken accentueren en een elegante aankleding creëren voor elk type ruimte: 120x120, 60x120, 60x60, 30x60 en de versie voor buiten OUT2.0. Het natuurlijke palet, met de kleuren Snow, Rock, Lava en Desert, wordt aangevuld door drie verschillende mozaïektypes: Muretto 3D, gekenmerkt door schuine groeven, Mosaico Linea, bestaande uit horizontale lamellen met verschillende hoogten, en Mosaico, dat vierkante en rechthoekige tegeltjes met onregelmatige afmetingen omvat.

Una combinación insólita de materiales lapideos provenientes de diferentes áreas del norte de Europa, seleccionados y mezclados para crear patrones y matices originales. Vetas delicadas, grano pequeño y superficies arenosas se funden en la colección Tune, disponible en formatos de tamaño grande y mediano que ensalzan el equilibrio de las superficies y permiten arropar con elegancia cualquier ambiente: 120x120, 60x120, 60x60, 30x60 y versión para exterior de OUT2.0. La paleta de colores naturales Snow, Rock, Lava y Desert se completa con tres tipos distintos de mosaicos: Muretto 3D, caracterizado por la presencia de surcos inclinados, Mosaico Linea, con franjas horizontales de distinta altura, y Mosaico, que incluye teselas cuadradas y rectangulares de dimensiones irregulares.

✂ 9 mm

120x120/48"x48" Soft R  
60x120/24"x48" Soft R  
60x60/24"x24" R  
60x60/24"x24" Soft R  
30x60/12"x24" R  
30x60/12"x24" Soft R

✂ 20 mm OUT2.0

90x90/36"x36" R  
60x90/24"x36" R  
60x60/24"x24" R

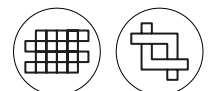

Gres porcellanato  
Porcelain stoneware  
Grès cérame fin vitrifié  
Feinsteinzeug  
Porseleingres  
Gres porcelánico

V3  
Moderate

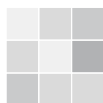

**Snow**

120x120/48"x48" Soft R	<b>MK17</b>
60x120/24"x48" Soft R	<b>NA90</b>
60x60/24"x24" R	<b>NB23</b>
60x60/24"x24" Soft R	<b>NB24</b>
30x60/12"x24" R	<b>NB11</b>
30x60/12"x24" Soft R	<b>NB12</b>

**Rock**

120x120/48"x48" Soft R	<b>MK15</b>
60x120/24"x48" Soft R	<b>NA88</b>
60x60/24"x24" R	<b>NB21</b>
60x60/24"x24" Soft R	<b>NB22</b>
30x60/12"x24" R	<b>NB09</b>
30x60/12"x24" Soft R	<b>NB10</b>
90x90/36"x36" R OUT2.0	<b>NA08</b>
60x90/24"x36" R OUT2.0	<b>NH51</b>
60x60/24"x24" R OUT2.0	<b>NH55</b>



**Lava**

120x120/48"x48" Soft R	<b>MK13</b>
60x120/24"x48" Soft R	<b>NA86</b>
60x60/24"x24" R	<b>NB19</b>
60x60/24"x24" Soft R	<b>NB20</b>
30x60/12"x24" R	<b>NB07</b>
30x60/12"x24" Soft R	<b>NB08</b>
90x90/36"x36" R OUT2.0	<b>NA07</b>
60x90/24"x36" R OUT2.0	<b>NH50</b>
60x60/24"x24" R OUT2.0	<b>NH54</b>

**Desert**

120x120/48"x48" Soft R	<b>MK11</b>
60x120/24"x48" Soft R	<b>NA84</b>
60x60/24"x24" R	<b>NA91</b>
60x60/24"x24" Soft R	<b>NA92</b>
30x60/12"x24" R	<b>NB05</b>
30x60/12"x24" Soft R	<b>NB06</b>
90x90/36"x36" R OUT2.0	<b>NH52</b>
60x90/24"x36" R OUT2.0	<b>NH49</b>
60x60/24"x24" R OUT2.0	<b>NH53</b>





V3  
Moderate



**Snow** 30x30/12"x12" Soft R **NA44**  
Mosaico

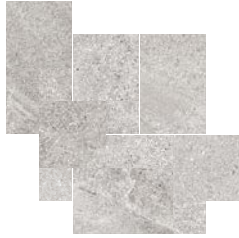

**Rock** 30x30/12"x12" Soft R **NA43**  
Mosaico



**Lava** 30x30/12"x12" Soft R **NA42**  
Mosaico



**Desert** 30x30/12"x12" Soft R **NA41**  
Mosaico



**Snow** 30x60/12"x24" R **MK50**  
Muretto 3D



**Rock** 30x60/12"x24" R **MK49**  
Muretto 3D

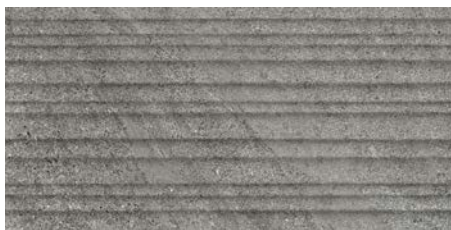

**Lava** 30x60/12"x24" R **MK48**  
Muretto 3D



**Desert** 30x60/12"x24" R **MK47**  
Muretto 3D

V3  
Moderate



Snow 30x60/12"x24" Soft R NA23  
Mosaico Linea  
(Mix 2)

Rock 30x60/12"x24" Soft R NA22  
Mosaico Linea  
(Mix 2)



Lava 30x60/12"x24" Soft R NA21  
Mosaico Linea  
(Mix 2)

Desert 30x60/12"x24" Soft R NA20  
Mosaico Linea  
(Mix 2)



## Pezzi speciali/Trim tiles/Pieces speciales/Formteile/Speciale delen/Piezas especiales

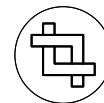

### Battiscopa



7x60/2<sup>7/8</sup>"x24" R

Desert	<b>MK42</b>
Lava	<b>MK43</b>
Rock	<b>MK44</b>
Snow	<b>MK45</b>

## Imballi/Packing/Emballage/Verpackungseinheiten/Verpakking/Embalajes

	pcs x box	m <sup>2</sup> / m x box	kg x box	box x pallet	m <sup>2</sup> x pallet	kg x pallet
120x120/48"x48"	2	2,8800	58,00	20	57,60	1160,00
60x120/24"x48"	2	1,4400	31,50	35	50,40	1102,50
60x60/24"x24"	3	1,0800	21,35	40	43,20	854,00
30x60/12"x24"	7	1,2600	25,00	40	50,40	1000,00
90x90/36"x36" <b>OUT2.0</b>	1	0,8100	37,60	18	14,58	676,80
60x90/24"x36" <b>OUT2.0</b>	2	1,0800	48,50	18	19,44	873,00
60x60/24"x24" <b>OUT2.0</b>	2	0,7200	32,40	30	21,60	972,00
30x30/12"x12" Mosaico	6	0,5400	10,20	36	19,44	367,20
30x60/12"x24" Mosaico Linea	4	0,7200	16,00	30	21,60	480,00
30x60/12"x24" Muretto 3D	5	0,9000	17,50	40	36,00	700,00
7x60/2 <sup>7/8</sup> "x24" Battiscopa	10	6,0000	9,00	70	420,00	630,00

The MATT and SOFT finishes are recommended for interior floors, walls, and exterior walls in both residential and commercial applications. Tune is not recommended for exterior horizontal surfaces or exterior paving, and they are not recommended for ramps application. The SOFT finish is not recommended for interior floors in entrance areas if joined to outdoor in commercial applications.

## SOFT Caratteristiche/Features/Caracteristiques/Eigenschaften/Eigenshappen/Características



UNI EN ISO 10545/14

Classe 5 / Class 5



B.C.R.A. Rep. CEC/81

Asciutto > 0,40 / Bagnato > 0,40



ANSI A137.1-2012 (BOT3000)

> 0,42 Wet

## MATT Caratteristiche/Features/Caracteristiques/Eigenschaften/Eigenshappen/Características



UNI EN ISO 10545/14

Classe 5 / Class 5



DIN 51130

R10  
R11 OUT2.0



DIN 51097

A+B  
A+B+C OUT2.0



BS 7976-2:2002  
(CENTS 16165, Annex C)  
Pendulum Friction Test

≥ 36 Wet



B.C.R.A. Rep. CEC/81

Asciutto > 0,40 /  
Bagnato > 0,40



ANSI A137.1-2012 (BOT3000)

> 0,42 Wet



Graphite 120×120/48"×48" R, 60×120/24"×48" R



## Urban exploration

Urbex Style nasce dall'osservazione del cemento segnato dal tempo, tipico degli edifici dismessi: il fascino di luoghi misteriosi e inesplorati rivive in una proposta di grande effetto visivo. La palette cromatica è composta da tre toni freddi, White, Grey, Graphite e da un tono caldo e particolarmente caratterizzato, Rough. I numerosi formati, tutti di grandi e medie dimensioni, enfatizzano l'estetica e la modernità delle superfici posate.

Urbex Style stems from the observation of concrete affected by time, typically found in abandoned buildings: the charm of mysterious, unexplored places is brought back to life in an offering with a strong visual impact. The colour palette consists of three cold colours, White, Grey, Graphite and a warm and particularly characterised hue, Rough. The multiple sizes, all of large and medium dimensions, emphasise the styling and modernity of the surfaces laid.

Urbex Style s'inspire du ciment usé par le temps, typique des édifices désaffectés : le charme des lieux mystérieux et inexplorés renaît dans une proposition offrant un effet visuel intéressant. La palette de couleurs est composée de trois tons froids – White, Grey, Graphite – et d'un ton chaud particulièrement caractéristique, Rough. Les nombreux formats, de moyennes et grandes dimensions, mettent en valeur l'esthétique et la modernité des surfaces posées.

Urbex Style entsteht aus der Beobachtung von durch die Zeit geprägtem Beton, so wie man ihn aus verfallenen Gebäuden kennt: Der Charme mysteriöser und unerforschter Orte wird in einem Projekt mit hervorragender optischer Wirkung in neues Leben gerufen. Die chromatische Palette besteht aus drei kalten Tönen - Weiß, Grau, Graphit - und einem warmen und besonders charakteristischen Ton - Rough. Die zahlreichen mittelgroßen bis großen Formate verleihen der Ästhetik und Modernität der verlegten Flächen eine noch stärkere Ausdruckskraft.

Urbex Style ontstaat uit de observatie van door de tijd getekend beton, kenmerkend voor verlaten gebouwen: de charme van mysterieuze en onontgonnen plaatsen herleeft in een concept met een veelzeggend visueel effect. Het kleurenpalet bestaat uit drie koude tinten, White, Grey, Graphite en een warme en bijzonder kenmerkende toon, Rough. De talrijke afmetingen, allemaal groot en middelgroot, benadrukken de esthetiek en moderniteit van de legvlakken.

Urbex Style nace de observar los signos del paso del tiempo que se producen en el cemento de edificios abandonados; el misterio que envuelve estos lugares inexplorados cobra vida en una propuesta de gran impacto visual. La paleta de colores se compone de tres tonos fríos, White, Grey y Graphite, y un tono cálido y particularmente característico, Rough. Los numerosos formatos, todos de tamaño mediano y grande, enfatizan la estética y la modernidad de las superficies colocadas.

✂ 9 mm

120x120/48"x48" R  
60x120/24"x48" R  
60x60/24"x24" R  
30x60/12"x24" R

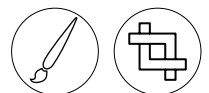

Gres porcellanato  
Porcelain stoneware  
Grès cérame fin vitrifié  
Feinsteinzeug  
Porseleingres  
Gres porcelánico

V3  
Moderate

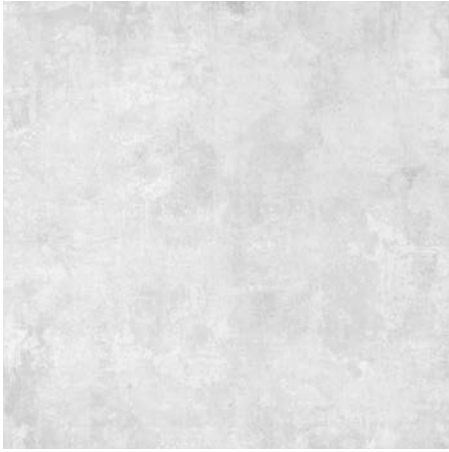

**White**      **120x120/48"x48" R**      **NP12**  
**60x120/24"x48" R**      **NQ66**  
**60x60/24"x24" R**      **NQ74**  
**30x60/12"x24" R**      **NQ77**



**Grey**      **120x120/48"x48" R**      **NP10**  
**60x120/24"x48" R**      **NQ64**  
**60x60/24"x24" R**      **NQ71**  
**30x60/12"x24" R**      **NQ72**



**Graphite**      **120x120/48"x48" R**      **NP09**  
**60x120/24"x48" R**      **NQ63**  
**60x60/24"x24" R**      **NQ70**  
**30x60/12"x24" R**      **NQ73**



**Rough**      **120x120/48"x48" R**      **NP11**  
**60x120/24"x48" R**      **NQ65**  
**60x60/24"x24" R**      **NQ75**  
**30x60/12"x24" R**      **NQ76**

White 120×120/48"×48" R

Urbex Style  
292/293



Decori/Decorative Motif/Decors/  
Dekore/Decoraties/Decoraciones



**Liberty**    **120x120/48"x48" R**    **NQ88**  
                  **60x120/24"x48" R**        **NQ89**

**Liberty 60x120/24"x48" R**



Rough 120x120/48"x48" R, 60x60/24"x24" R — Liberty 60x120/24"x48" R

Urbex Style  
294/295





## Pezzi speciali/Trim tiles/Pieces speciales/Formteile/Speciale delen/Piezas especiales

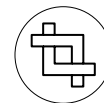

### Battiscopa

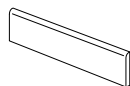

7x60/2<sup>7/8</sup>"x24" R

White	NP26
Grey	NP24
Graphite	NP23
Rough	NP25

## Imballi/Packing/Emballage/Verpackungseinheiten/Verpakking/Embalajes

	pcs x box	m <sup>2</sup> / m x box	kg x Box	box x pallet	m <sup>2</sup> / m x pallet	kg x pallet
120x120/48"x48"	2	2,8800	58,00	20	57,60	1160,00
60x120/24"x48"	2	1,4400	31,50	35	50,40	1102,50
60x60/24"x24"	3	1,0800	21,35	40	43,20	854,00
30x60/12"x24"	7	1,2600	25,00	40	50,40	1000,00
7x60/2 <sup>7/8</sup> "x24" Battiscopa	10	6,0000	9,00	70	420,00	630,00

## Caratteristiche/Features/Caracteristiques/Eigenschaften/Eigenshappen/Características



UNI EN ISO 10545/14

Classe 5 / Class 5



DIN 51130

R10



BS 7976-2:2002 (CEN/TS 16165, Annex C) Pendulum Friction Test

≥ 36 Wet



B.C.R.A. Rep. CEC/81

Asciutto > 0,40 /  
Bagnato > 0,40



ANSI A137.1-2012 (BOT3000)

> 0,42 Wet

Grey 120×120/48"×48" R



Lux Bianco 120x120/48"x48" Lucido R —  
Lux Bianco 120x278/48"x110" Lucido R



## Glossy vibe

Il vetro è un materiale dotato di limpidezza ed armonia intrinseca, caratterizzato da una propria duplicità: trasparente e opaco, fragile e robusto allo stesso tempo. Dal suo studio nasce la collezione ceramica Vetri. Forte delle tecnologie produttive più avanzate, Ceramiche Refin ha sviluppato una propria ricerca che si esprime nella creazione di originali superfici dal marcato carattere innovativo. Vetri è una collezione dalla forte identità: la delicata sfumatura che ne delimita i bordi crea una superficie dall'inedita profondità e un elegante reticolo geometrico. La finitura lucida riflette ed enfatizza la luce, conferendo agli ambienti una luminosità dal fascino senza tempo.

Glass is a material that offers intrinsic clarity and harmony, distinguished by its very own duality: transparent and matt, fragile and at the same time sturdy. A study of this material led to the creation of the Vetri ceramic tile collection. Backed by the most sophisticated manufacturing technologies, Ceramiche Refin has developed its own research which is expressed in the creation of original surfaces with a notable innovative personality. Vetri is a collection with a strong identity: the delicate colour variations that mark the edges create a surface with an unprecedented depth and an elegant geometrical mesh. The glossy finishing reflects and emphasises light, lending its surroundings a brightness with evergreen charm.

Le verre est un matériau intrinsèquement limpide et harmonieux, caractérisé par une dualité qui lui est propre : transparent ou opaque, à la fois fragile et solide. Son étude a donné naissance à la collection céramique Vetri. Grâce aux technologies de production les plus avancées, Ceramiche Refin a développé ses recherches qui s'expriment dans la création de surfaces originales au caractère innovant marqué. Vetri est une collection à l'identité forte : la nuance délicate qui délimite les bords crée une surface d'une profondeur inédite et un cadrillage géométrique élégant. La finition brillante reflète et accentue la lumière, en apportant aux espaces une luminosité au charme intemporel.

Glas ist ein klares und harmonisches Material, das sich durch eine eigene Doppeldeutigkeit auszeichnet: transparent und matt, zerbrechlich und robust zugleich. Aus seiner Studie entsteht die Kollektion Ceramica Vetri. Dank modernster Produktionstechnologien hat Ceramiche Refin eine eigene Forschung entwickelt, die sich in der Schaffung von Originaloberflächen mit einem ausgeprochen innovativen Charakter ausdrückt. Vetri ist eine Kollektion mit einer starken Identität: Die zarte Nuance, die die Kanten begrenzt, schafft eine Oberfläche von beispielloser Tiefe und ein elegantes geometrisches Raster. Die glänzende Oberfläche reflektiert und betont das Licht und verleiht den Räumen eine zeitlos charmante Helligkeit.

Glas is een materiaal vol helderheid en intrinsieke harmonie, waarin een onverenigbare tweeledigheid is samengebracht. Glas is enerzijds tegelijk transparant en mat en kenmerkt zich anderzijds door zowel een kwetsbare als een robuuste kant. Uit het onderzoek naar dit materiaal is de keramische collectie Vetri ontstaan. Door haar geavanceerde productietechnologieën en eigen onderzoek is Ceramiche Refin steeds weer in staat originele bekledingen te creëren met een duidelijk innovatief karakter. Vetri is een collectie met een sterke eigen identiteit: de verfijnde nuances langs de randen geven het beklede oppervlak een ongekennde diepte en een elegante raster vorm. De glanzende afwerking weerspiegelt en benadrukt de lichtinval en biedt de ruimte daardoor een tijdloos lichtspel.

El vidrio es un material dotado de claridad y armonía intrínsecas, caracterizado por su duplicidad: transparente y opaco, frágil y robusto al mismo tiempo. La colección de cerámica Vetri es el resultado de su estudio. Contando con las tecnologías de producción más avanzadas, Ceramiche Refin ha desarrollado su propia investigación que se expresa en la creación de superficies originales con un marcado carácter innovador. Vetri es una colección con una fuerte identidad: el delicado matiz que delimita los cantos crea una superficie con una profundidad sin precedentes y una elegante retícula geométrica. El acabado brillante refleja y resalta la luz, aportando a los ambientes un encanto atemporal.

✂ 6 mm

120x278/48"x110" Lucido R

✂ 9 mm

120x120/48"x48" Lucido R  
60x60/24"x24" Lucido R  
30x60/12"x24" Lucido R  
20x60/8"x24" Lucido R  
10x30/4"x12" Lucido R



Gres porcellanato  
Porcelain stoneware  
Grès cérame fin vitrifié  
Feinsteinzeug  
Porseleingres  
Gres porcelánico



NCS - Natural Colour System®  
property of and used on licence from  
NCS Colour AB, Stockholm 2020.  
The colours might not exactly match  
original NCS colour samples.

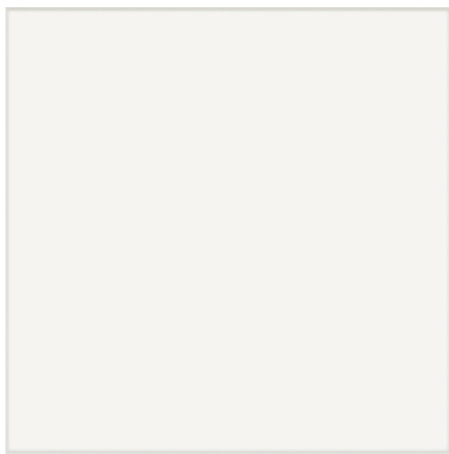

**Bianco**  
 120x278/48"x110" Lucido R  
 120x120/48"x48" Lucido R  
 60x60/24"x24" Lucido R  
 30x60/12"x24" Lucido R  
 20x60/8"x24" Lucido R  
 10x30/4"x12" Lucido R

**NP38**  
**NQ31**  
**MK81**  
**NH10**  
**ND75**  
**ND80**



**Naturale**  
 120x278/48"x110" Lucido R  
 120x120/48"x48" Lucido R  
 60x60/24"x24" Lucido R  
 30x60/12"x24" Lucido R  
 20x60/8"x24" Lucido R  
 10x30/4"x12" Lucido R

**NP40**  
**NQ32**  
**MK83**  
**NH12**  
**ND78**  
**ND83**



**Bronzo**  
 60x60/24"x24" Lucido R  
 30x60/12"x24" Lucido R  
 20x60/8"x24" Lucido R  
 10x30/4"x12" Lucido R

**MK18**  
**NH11**  
**ND76**  
**ND81**

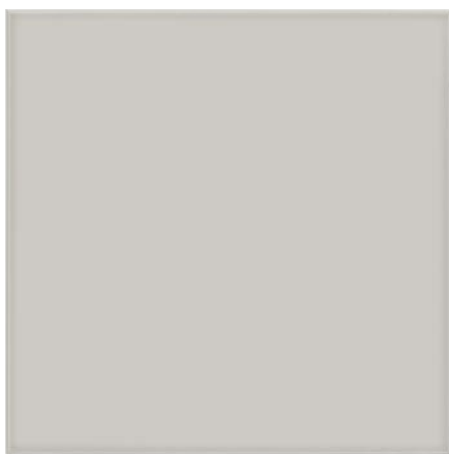

**Fumé**  
 60x60/24"x24" Lucido R  
 30x60/12"x24" Lucido R  
 20x60/8"x24" Lucido R  
 10x30/4"x12" Lucido R

**MK82**  
**NH13**  
**ND77**  
**ND82**



**Acqua**  
 60x60/24"x24" Lucido R  
 30x60/12"x24" Lucido R  
 20x60/8"x24" Lucido R  
 10x30/4"x12" Lucido R

**NE70**  
**NH09**  
**ND74**  
**ND79v**

Fumé 30x60/12"x24" Lucido R — 10x30/4"x12" Lucido R

Vetri  
300/301



Decori/Decorative Motif/Decors/  
Dekore/Decoraties/Decoraciones



8 soggetti diversi formato 30x60 (miscelazione casuale)/  
8 assorted motifs 30x60 size (random mix)/  
8 sujets differents format 30x60 (melange aleatoire)/  
8 Verschiedene Motive Format 30x60 (Zufallsmischung)/  
8 verschillende ontwerpen in 30x60 (willekeurig gemengd)/  
8 motivos diferentes formato 30x60 (mezcla aleatoria)

Piet 30x60/12"x24" Lucido R NQ87

Bronzo 60x60/24"x24" Lucido R — Piet 30x60/12"x24" Lucido R







## Imballi/Packing/Emballage/Verpackungseinheiten/Verpakking/Embalajes





	pcs x box	m <sup>2</sup> / m x box	kg x box	box x pallet	m <sup>2</sup> x pallet	kg x pallet
120x278/48"x110"	1	3,3360	49,56	18	60,05	892,08
120x120/48"x48"	2	2,8800	58,00	20	57,60	1160,00
60x60/24"x24"	3	1,0800	21,35	40	43,20	854,00
30x60/12"x24"	7	1,2600	25,00	40	50,40	1000,00
20x60/8"x24"	7	0,8400	18,20	48	40,32	873,60
10x30/4"x12"	20	0,6000	13,10	72	43,20	943,20

## Corrispondenze cromatiche / Colour matches / Correspondances chromatiques / Chromatische Entsprechungen / Chromatische correspondenties / Correspondencias cromáticas.

Vetri	NCS®
Acqua	S 3010-G20Y
Bianco	S 1000-N
Bronzo	S 3005-Y20R
Fumé	S 2500-N
Naturale	S 2005-B80G

NCS - Natural Colour System® property of and used on licence from NCS Colour AB. Stockholm 2020.  
The colours might not exactly match original NCS colour samples.

## Caratteristiche/Features/Caracteristiques/Eigenschaften/Eigenschappen/Características

				
UNI EN ISO 10545/7	UNI EN ISO 10545/14	UNI EN ISO 10545/15	B.C.R.A. Rep. CEC/81	ANSI A137.1-2012 (BOT3000)
PEI III (1500 rev) Acqua	Conforme / Compliant	Pb < 0,01 mg/dm <sup>2</sup> Cd < 0,001 mg/dm <sup>2</sup>	Non conforme / Failed	Non conforme / Failed
PEI V (>12000 rev) Bianco, Naturale				
PEI IV (2100 rev) Fumé, Bronzo				

### For USA, Canada and Oceania markets

Vetri is not recommended for the exterior horizontal surfaces or exterior paving, and it is not recommended for ramps application.

Vetri LUCIDO is recommended for interior walls and exterior walls both in residential and commercial applications.

Vetri LUCIDO finish is not recommended for floors.

### Warning

The LUCIDO (Glossy) finish does not meet the minimum coefficient of friction, according to the most relevant national standards for antislip resistance (as per example: ANSI 137.1-2012 / BOT3000; b.C.R.A. REP. CEC/81; DIN 51130; DIN 51097).



Lead 120x120/48"x48" R



# Wide

# 306/307

## Slate recall

Un prodotto dal carattere moderno: alonature, nuvolature e lievi graffi intervengono sulla monocromia dell'ardesia, enfatizzandone la matericità e rinnovandola con un linguaggio attuale. Grazie alle dimensioni importanti (120x120, 60x120) e alla versione OUT2.0 (60x60), Wide è ideale per sviluppare grandi progetti per luoghi di forte transito e per ambienti di rappresentanza/hospitality, mentre i formati più piccoli (60x60 e 30x60) trovano perfetta collocazione anche in ambito residenziale. La gamma presenta cinque colorazioni – un bianco, due grigi, un nero, un fango – sia nella versione liscia che in quella strutturata da esterno, più due tinte in OUT2.0.

This product has a contemporary feel: stains, cloudy effects and slight scratches enliven the plain colour of the slate, bringing out the character of the material used and making it more up-to-date. The large sizes (120x120, and 60x120) and the version OUT2.0 (60x60), make Wide ideally suited for covering large, heavy-duty areas and for showrooms and reception areas, while the smaller sizes (60x60 and 30x60) are also perfect in the home. There are five colours in the range – white, two shades of grey, black and mud brown – both in the smooth version and the structured variant for outdoor use, plus two shades in the version OUT2.0.

Un produit à l'esprit moderne, avec des détails auréolés, nuagés et de légères griffures ponctuant la monochromie de l'ardoise dont ils rehaussent l'évocation de la matière tout en l'actualisant par une expression contemporaine. Grâce à ses dimensions importantes (120x120, 60x120) et à sa version OUT2.0 (60x60), Wide est idéale pour réaliser de grands projets dans des lieux très fréquentés et des espaces de représentation et d'accueil, tandis que les formats plus petits de 60x60 et 30x60, sont parfaits dans le secteur résidentiel. La gamme présente cinq coloris – un blanc, deux gris, un noir et un boue – aussi bien dans la version simple que dans la version structurée pour l'extérieur, ainsi que deux teintes pour OUT2.0.

Ein Produkt mit einem modernen Charakter: Flecken, Marmoreffekte und kleinere Kratzer durchbrechen den monochromen Eindruck des Schiefers, betonen die besondere Materialwirkung und interpretieren die Fliese auf moderne Weise neu. Dank der Großformate (120x120, 60x120) und der Ausführung OUT2.0 (60x60) ist Wide ideal für Großprojekte, insbesondere für stark frequentierte Bereiche, repräsentative Räume und das Gastgewerbe, während sich die kleinen Formate (60x60 und 30x60) ausgezeichnet für Wohnungen eignen. Das Sortiment umfasst fünf Farben - ein Weißton, zwei Grautöne, ein Schwarzton, ein Schlammtön - die alle sowohl in der glatten als auch in der strukturierten Version erhältlich sind. Dazu kommen zwei Farbtöne in der Version OUT2.0.

Een product met modern karakter: kringen, wolken en lichte krasjes interfereren op monochromatische leisteen en resulteren in een zeer actuele tegel met "materisch" karakter. Dankzij de aanzienlijke afmetingen (120x120, 60x120) en de versie OUT2.0 (60x60) is Wide ideaal voor ontwerp van grote omgevingen met veel doorgang en voor commerciële omgevingen voor onthaal/representatie, terwijl de kleinere formaten (60x60 en 30x60) zich perfect thuis voelen in residentiële omgevingen. Het gamma bestaat uit vijf kleuren – één witte, twee moddergrijze – zowel voor de gladde versie, als voor de gestructureerde buitenversie, plus twee tinten in OUT2.0.

Un producto de toque moderno: matices, vetas y leves rayas intervienen en la monocromía de la pizarra exaltando aún más su materia y renovándola con un estilo actual. Gracias a las grandes dimensiones (120x120 y 60x120) y a la versión OUT2.0 (60x60), Wide es ideal para desarrollar grandes proyectos en espacios de elevado tránsito y en aquellos destinados a la exhibición/hospitality. Los formatos más pequeños (60x60 y 30x60) son en cambio perfectos para la colocación en contextos residenciales. La gama dispone de cinco tonos (1 blanco, 2 grises, 1 negro y 1 lodo) tanto en la versión lisa como en la estructurada para exterior, y de otras dos tonalidades en OUT2.0.

✂ 9 mm

120x120/48"x48" R  
60x120/24"x48" R  
60x60/24"x24" R  
60x60/24"x24" R Strutt.  
30x60/12"x24" R  
30x60/12"x24" R Strutt.

✂ 20 mm OUT2.0

60x60/24"x24" R Strutt.



Gres porcellanato  
Porcelain stoneware  
Grès cérame fin vitrifié  
Feinsteinzeug  
Porseleingres  
Gres porcelánico

V2  
Slight

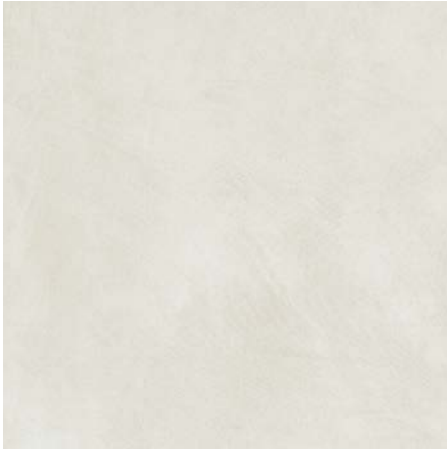

**Chalk**    **120x120/48"x48" R**    **LJ08**  
**60x120/24"x48" R**    **LJ74**  
**60x60/24"x24" R**    **LJ79**  
**30x60/12"x24" R**    **NE22**



**Steel**    **120x120/48"x48" R**    **LJ11**  
**60x120/24"x48" R**    **LJ77**  
**60x60/24"x24" R**    **LJ82**  
**30x60/12"x24" R**    **NE19**

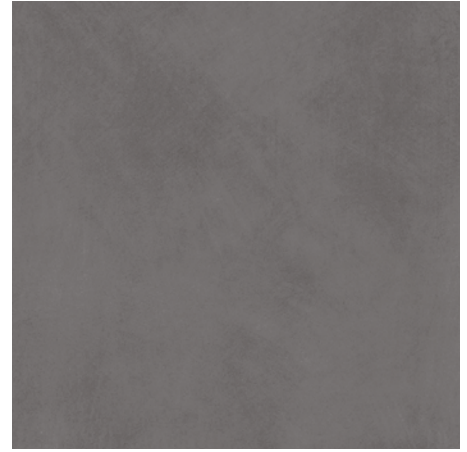

**Lead**    **120x120/48"x48" R**    **LJ09**  
**60x120/24"x48" R**    **LJ75**  
**60x60/24"x24" R**    **LJ80**  
**30x60/12"x24" R**    **NE21**



**Carbon**    **120x120/48"x48" R**    **LJ07**  
**60x120/24"x48" R**    **LJ73**  
**60x60/24"x24" R**    **LJ78**  
**30x60/12"x24" R**    **NE23**

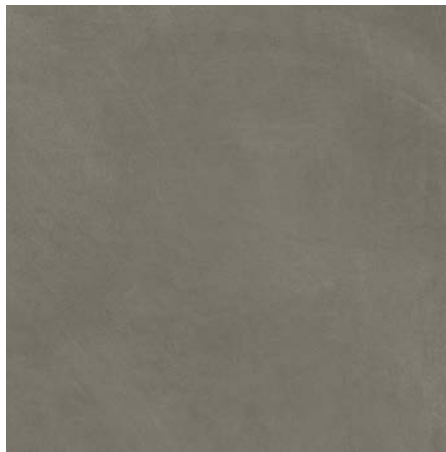

**Olive**    **120x120/48"x48" R**    **LJ10**  
**60x120/24"x48" R**    **LJ76**  
**60x60/24"x24" R**    **LJ81**  
**30x60/12"x24" R**    **NE20**



**Chalk Strutt.** 60x60/24"x24" R  
30x60/12"x24" R **LP74 NE17**

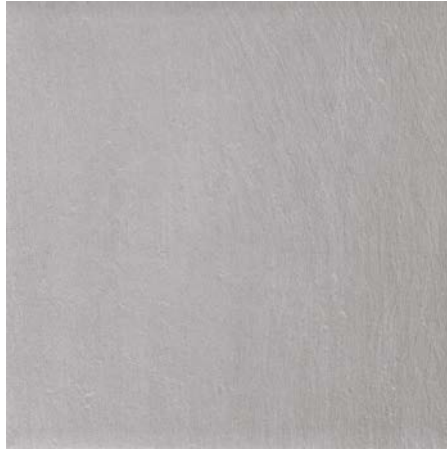

**Steel Strutt.** 60x60/24"x24" R  
30x60/12"x24" R  
60x60/24"x24" R **OUT2.0** **LP73 NE14 LJ01**



**Lead Strutt.** 60x60/24"x24" R  
30x60/12"x24" R **LP70 NE16**



**Carbon Strutt.** 60x60/24"x24" R  
30x60/12"x24" R  
60x60/24"x24" R **OUT2.0** **LP71 NE18 LJ02**



**Olive Strutt.** 60x60/24"x24" R  
30x60/12"x24" R **LP72 NE15**



**Chalk**      **60x60/24"x24" R**      **LO57**  
**Sketch 1**

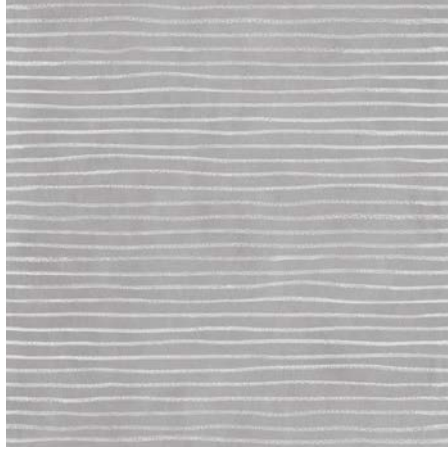

**Steel**      **60x60/24"x24" R**      **LO60**  
**Sketch 1**



**Lead**      **60x60/24"x24" R**      **LO58**  
**Sketch 1**

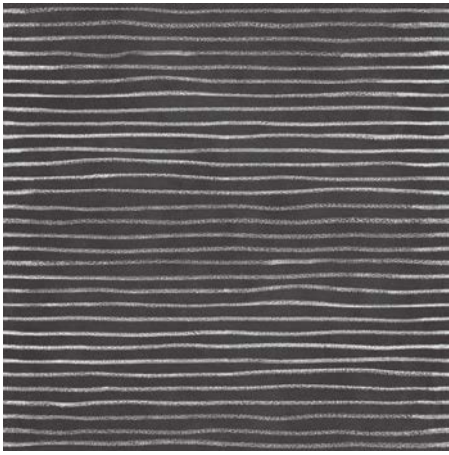

**Carbon**      **60x60/24"x24" R**      **LO56**  
**Sketch 1**



**Olive**      **60x60/24"x24" R**      **LO59**  
**Sketch 1**

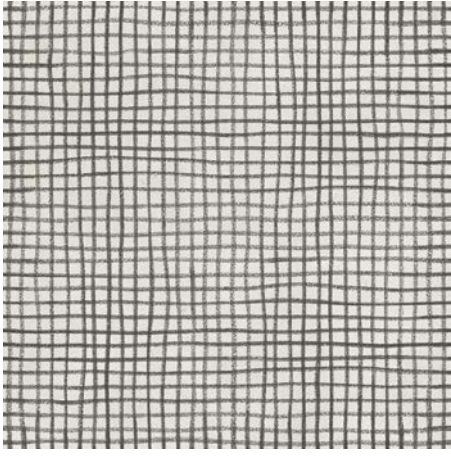

Chalk Sketch 2 60x60/24"x24" R LO62

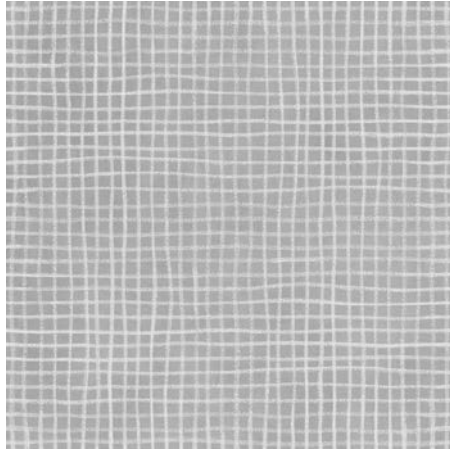

Steel Sketch 2 60x60/24"x24" R LO65

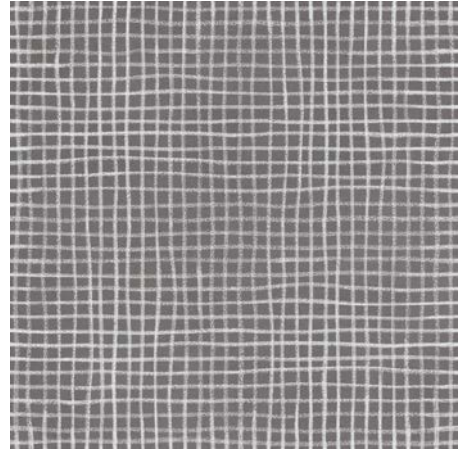

Lead Sketch 2 60x60/24"x24" R LO63

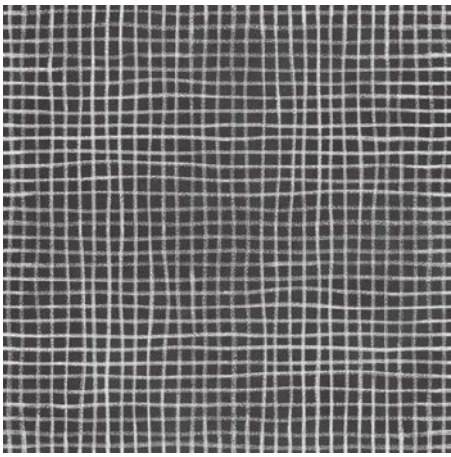

Carbon Sketch 2 60x60/24"x24" R LO61

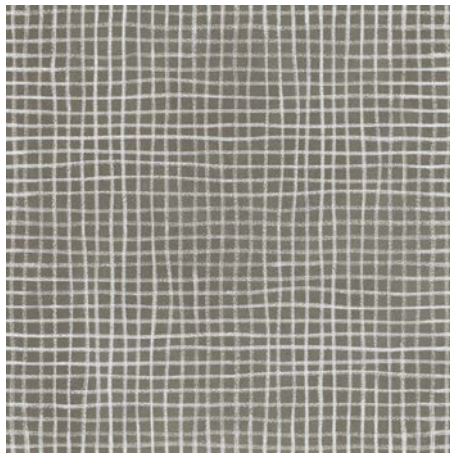

Olive Sketch 2 60x60/24"x24" R LO64



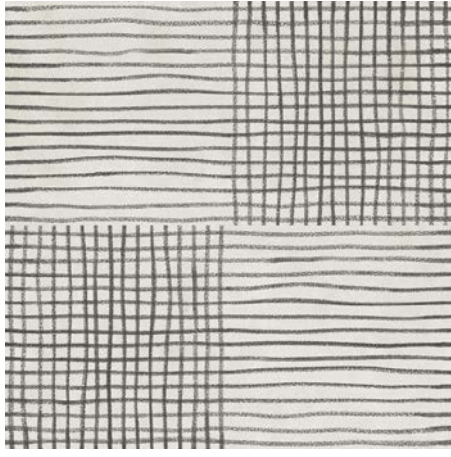

Chalk Sketch 3 60x60/24"x24" R LO67

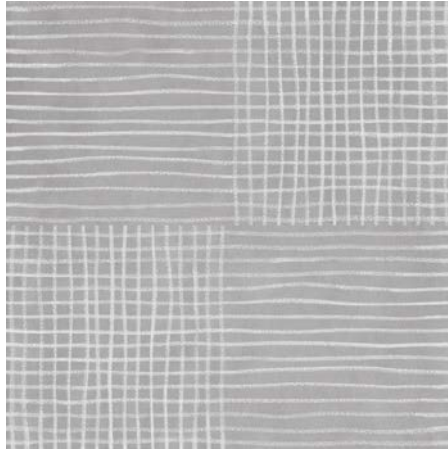

Steel Sketch 3 60x60/24"x24" R LO70

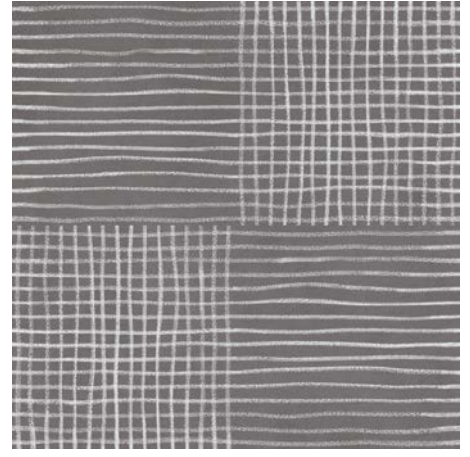

Lead Sketch 3 60x60/24"x24" R LO68

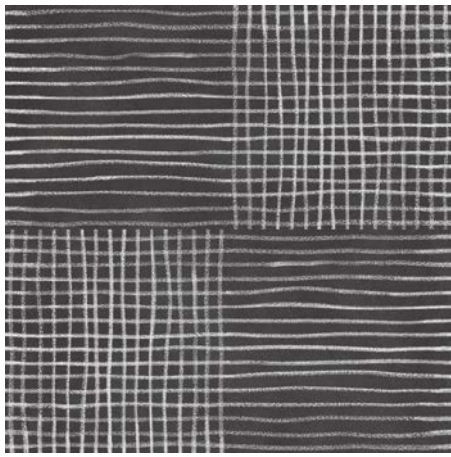

Carbon Sketch 3 60x60/24"x24" R LO66

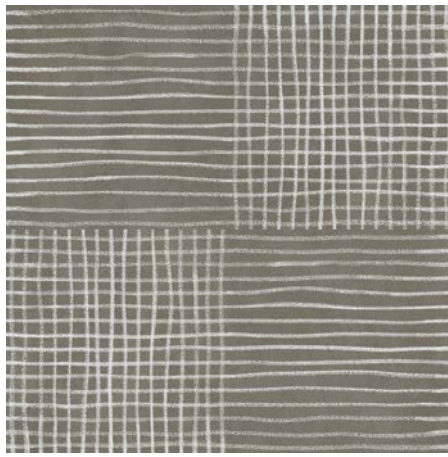

Olive Sketch 3 60x60/24"x24" R LO69

Carbon 60x60/24"x24" R — Carbon Sketch 2 60x60/24"x24" R — Chalk 60x120/24"x48" R — Chalk Sketch 1 60x60/24"x24" R





V2  
Slight

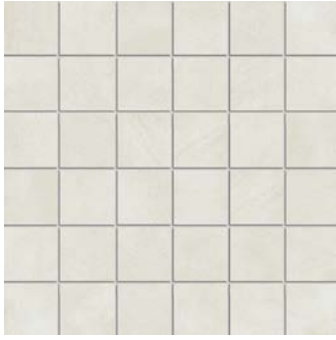

Chalk 30x30/12"x12" R MG85  
Mosaico

Chalk 30x30/12"x12" R MT40  
Mosaico  
Strutt.



Steel 30x30/12"x12" R MG87  
Mosaico

Steel 30x30/12"x12" R MO99  
Mosaico  
Strutt.

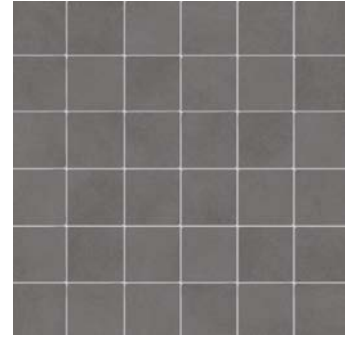

Lead 30x30/12"x12" R MG86  
Mosaico

Lead 30x30/12"x12" R MT41  
Mosaico  
Strutt.

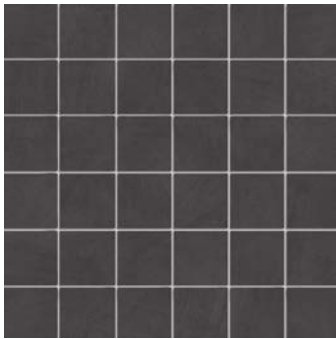

Carbon 30x30/12"x12" R MG84  
Mosaico

Carbon 30x30/12"x12" R MT39  
Mosaico  
Strutt.



Olive 30x30/12"x12" R MG88  
Mosaico

Olive 30x30/12"x12" R MW11  
Mosaico  
Strutt.

Pezzi speciali/Trim tiles/Pieces speciales/Formteile/Speciale delen/Piezas especiales



Battiscopa

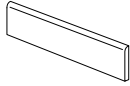

7x60/2<sup>7/8</sup>"x24" R

Carbon	LJ99
Chalk	LK00
Lead	LK01
Olive	LK02
Steel	LK03

Imballi/Packing/Emballage/Verpackungseinheiten/Verpakking/Embalajes

	pcs x box	m <sup>2</sup> / m x box	kg x Box	box x pallet	m <sup>2</sup> / m x pallet	kg x pallet
120x120/48"x48"	2	2,8800	58,00	20	57,60	1160,00
60x120/24"x48"	2	1,4400	31,50	35	50,40	1102,50
60x60/24"x24"	3	1,0800	21,35	40	43,20	854,00
30x60/12"x24"	7	1,2600	25,00	40	50,40	1000,00
60x60/24"x24" OUT2.0	2	0,7200	32,40	30	21,60	972,00
30x30/12"x12" Mosaico	11	0,9900	19,00	18	17,82	342,00
7x60/2 <sup>7/8</sup> "x24" Battiscopa	10	6,0000	9,00	70	420,00	630,00

Caratteristiche/Features/Caracteristiques/Eigenschaften/Eigenschappen/Características



UNI EN ISO 10545/14

Classe 5 / Class 5



DIN 51130

R9  
R10 Strutt.  
R11 OUT2.0



DIN 51097

A+B Strutt.  
A+B+C OUT2.0



BS 7976-2:2002 (CEN/TS 16165,  
Annex C) Pendulum Friction Test

≥ 36 Wet Strutt.



B.C.R.A. Rep. CEC/81

Asciutto > 0,40 /  
Bagnato > 0,40



ANSI A137.1-2012 (BOT3000)

> 0,42 Wet

Scuro 90x90/36"x36" R.OUT2.0



# OUT2.0

# 316/317

## Outdoor solution

OUT2.0: il grès porcellanato Refin in spessore 20 mm, specificamente progettato per applicazioni outdoor. Perfetto per giardini, piscine e coperture, OUT2.0 è frutto della ricerca Refin in ambito outdoor e coniuga al meglio performance, estetica e versatilità. Ingelivo, resistente agli attacchi chimici e agli agenti atmosferici, è la scelta ideale per la posa in ambienti esterni residenziali e commerciali. OUT2.0 mantiene inalterate nel tempo le eccezionali qualità tecniche e può essere posato in tre diverse modalità: posa sopraelevata con supporti, posa diretta su ghiaia e terreno, posa tradizionale con collante.

OUT2.0: 20 mm thick porcelain stoneware by Refin, designed specifically for outdoor applications. Perfect for gardens, swimming pools and coverings, OUT2.0 is the result of Refin's research into solutions for outdoors offering the ideal combination of performance, looks and versatility. Resistant to frost, chemicals and harsh weather conditions, it is the ideal choice for residential or commercial applications out of doors. The exceptional technical features of OUT2.0 are not affected by the passing of time and it can be fitted using one of the three following methods: raised flooring with supports, directly on top of gravel or soil, or using the tradition solution with adhesive.

OUT2.0: le grès cérame Refin produit en 20 mm d'épaisseur, expressément projeté pour être appliqué à l'extérieur. À la fois performant, esthétique et éclectique, OUT2.0 est idéal pour les jardins, les piscines et autres couvertures. Il représente l'aboutissement de travaux de recherche que Refin a menés dans le cadre des applications à l'extérieur. Ingélif, résistant aux attaques chimiques et aux agents atmosphériques, il s'adapte à la perfection aux espaces extérieurs aussi bien résidentiels que commerciaux. OUT2.0 est durable et conserve ses exceptionnelles qualités techniques dans le temps et peut être posé selon trois modalités tout à fait différentes: pose surélevée sur plots, pose directe sur un lit de gravier et terre battue, pose scellée sur chape avec adhésif.

OUT2.0: Refin Feinsteinzeug in einer Stärke von 20 mm, speziell für Outdoor-Anwendungen. Perfekt für Gärten, Pools und Aussenräume, OUT2.0 ist das Ergebnis der Forschung und Entwicklung von Refin im Outdoorbereich. Dieses Feinsteinzeug kombiniert Leistung, Ästhetik und Vielseitigkeit auf bestmögliche Weise. OUT2.0 ist frostsicher, chemikalienbeständig und witterungsbeständig und somit die ideale Wahl für die Verlegung in privaten und gewerblichen Außenbereichen. OUT2.0 behält dauerhaft eine außergewöhnliche technische Qualität und kann auf drei verschiedene Arten verlegt werden: als Doppelboden auf Trägern und Stützen, direkt auf Kies und Erde, auf herkömmliche Weise mit Kleber.

OUT2.0: 20 mm dik gres porcellanato van Refin, specifiek ontworpen voor outdoor toepassingen. OUT2.0 is perfect voor tuinen, zwembaden en dakbedekking en vormt het resultaat van onderzoek van het Refin team naar outdoor oplossingen. Een optimale combinatie van prestaties, esthetiek en veelzijdigheid. Vriesbestendig, bestendig tegen chemische aantastingen en atmosferische invloeden, de ideale keuze voor outdoor plaatsing in een privé of commerciële context. De buitengewone technische kenmerken van OUT2.0 blijven ongewijzigd in de tijd. Plaatsing kan gebeuren volgens drie verschillende modaliteiten: plaatsing in verhoogde vloeren met steunen, rechtstreekse plaatsing op kiezel en grond, traditionele plaatsing met kleefmiddel.

OUT2.0: el gres porcelánico Refin con 20 mm de espesor, específicamente diseñado para aplicaciones de exterior. Perfecto para jardines, piscinas y cerramientos, OUT2.0 es fruto de la investigación de Refin para el exterior y combina de la mejor manera rendimiento, estética y versatilidad. Resistente al hielo, a los ataques químicos y a los agentes atmosféricos, es la elección ideal para la colocación en espacios de exterior y comerciales. OUT2.0 mantiene inalteradas en el tiempo sus excepcionales calidades técnicas y puede colocarse de 3 maneras diferentes: colocación sobre elevada con soportes, colocación directa sobre grava y terreno, y colocación tradicional con cola.

### 20 mm OUT2.0

40x120/16"x48" R  
90x90/36"x36" R  
60x90/24"x36" R  
45x90/18"x36" R  
60x60/24"x24" R

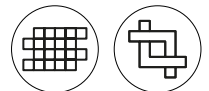

Gres porcellanato  
Porcelain stoneware  
Grès cérame fin vitrifié  
Feinsteinzeug  
Porseleingres  
Gres porcelánico

# OUT2.0

La lastra monolitica perfettamente squadrata e monocalibre in spessore 20 mm, consente una posa più semplice e rapida rispetto ad altri materiali con bordo discontinuo. OUT2.0 è inoltre sinonimo di versatilità: più leggero e pratico paragonato ai conglomerati cementizi ed alle pietre naturali; garantisce un'elevata resistenza ai carichi di rottura consentendo contemporaneamente continuità stilistica con il pavimento posato in interno. Facile da pulire e resistente alle macchie, OUT2.0 non necessita di trattamenti specifici, all'insegna di una consolidata facilità di manutenzione. A completamento del progetto, una ricca gamma di pezzi speciali garantisce finiture ineccepibili.

The monolithic slab is perfectly squared with a single work-size in a thickness of 20 mm, making tiling easier and faster compared to other materials with uneven edges. OUT2.0 is also synonymous with versatility: it is lighter and more practical than cement-based concrete and natural stone, guaranteeing an excellent load-bearing capacity and resistance to breakage, while enabling design continuity with any flooring fitted indoors. Since it is easy to clean and stain resistant, OUT2.0 does not need any special treatments, making its maintenance demands particularly easy going. A full range of trim tiles completes the line, making it possible to obtain a truly excellent finished result.

Sa dalle monolithique parfaitement d'équerre et monocalibre d'une épaisseur de 20 mm, permet une pose plus simple et plus rapide qu'avec d'autres matériaux à bord irrégulier. OUT2.0 est aussi synonyme d'adaptabilité. En effet, c'est un produit plus léger et plus pratique que les mélanges en béton et les pierres naturelles. Il est extrêmement résistant aux charges de rupture, ce qui permet d'assurer à l'extérieur la continuité stylistique du carrelage de sol posé à l'intérieur. Caractérisé par une excellente nettoyabilité et une bonne résistance aux taches, OUT2.0 ne requiert aucun traitement particulier. C'est donc un produit facile à entretenir. Un vaste choix de pièces spéciales complète la gamme, assurant des finitions impeccables.

Die perfekt quadratische monolithische Platte in einem einheitlichen Werkmaß und in 20 mm Stärke erlaubt eine einfachere und schnellere Verlegung gegenüber anderen Materialien mit nicht einheitlichen Kanten. OUT2.0 steht auch für Vielseitigkeit: Das Material ist im Vergleich zu Beton leichter und praktischer und gewährleistet eine hohe Belastbarkeit und gleichzeitig eine stilistische Kontinuität mit dem in Innenräumen verlegten Boden. OUT2.0 ist leicht zu reinigen und fl eckenbeständig und erfordert für eine dauerhafte Pfl egeleichtigkeit keine spezielle Behandlung. Zur Ergänzung gibt es außerdem ein breites Angebot an Formteilen für eine perfekte Ausführung.

Plaatsing gebeurt makkelijker dan bij materialen met onregelmatige boorden, dankzij de perfect recht afgekante monolietplaat met één enkele dikte 20 mm. OUT2.0 is bovendien synoniem voor veelzijdigheid: lichter en praktischer in vergelijking met cementconglomeraten en natuurstenen; garandeert een grote weerstand tegen breukbelastingen en zorgt tegelijkertijd voor stilistische continuïteit met de binnenvloer. Makkelijk schoon te maken en viekbestendig. OUT2.0 vereist geen bijzondere behandelingen en is derhalve onderhoudsvriendelijk. Een rijk gamma aan speciale onderdelen garandeert een onberispelijke afwerking van het ontwerp.

La losa monolítica perfectamente descuadrada y monocalibre con 20 mm de espesor, permite una colocación más fácil y rápida con respecto a otros materiales de borde discontinuo. OUT2.0 es además sinónimo de versatilidad: más ligero y práctico comparado con los aglomerados de cemento y con las piedras naturales. Garantiza una elevada resistencia a las cargas de rotura a la vez que permite continuidad estilística con las baldosas colocadas en el interior. Fácil de limpiar y resistente a las manchas, OUT2.0 no requiere tratamientos específicos, lo que muestra su consolidada facilidad de mantenimiento. Una rica gama de piezas especiales, que garantiza acabados perfectos, completa este proyecto.

Plain Cinder OUT2.0 90x90/36"x36" R





Facile da posare/Easy to install/Facile à poser/Leicht verlegbar/Makkelijk te plaatsen/Fácil de colocar



Resistente ai carichi di rottura/Resistant to breaking loads/Résistant aux charges de rupture/Äusserst belastbar (hohe Bruchfestigkeit)/Grote weerstand tegen breukbelastingen/Resistente a las cargas de rotura

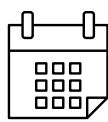

Inalterabile nel tempo/Unaffected by the passing of time/Inaltérable, même à long terme/Zeitbeständig (lange Lebensdauer)/Onwijzigbaar in de tijd/Inalterable en el tiempo

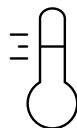

Resistente agli sbalzi termici/Resistant to thermal shock/Résistant aux chocs thermiques/Unempfindlich gegenüber Temperaturschwankungen/Bestendig tegen temperatuurwisselingen/Resistente a los cambios climáticos



Elevate performance antiscivolo/Superior non slip performance/Antidérapant haute performance/Hohe Trittsicherheit/Extra slipvast/Elevadas prestaciones antiresbalamiento



Facile da pulire/Easy to clean/Facile à nettoyer/Pflegeleicht/Makkelijk schoon te maken/Fácil de limpiar



Perfetto coordinamento in/out/Perfect indoor/outdoor coordination/Coordination parfaite entre intérieur et extérieur/Perfekte Abstimmung zwischen Innen- und Aussenbereich/Perfect samenspel tussen binnen- en buitenvloer/Perfecta coordinación interior/exterior

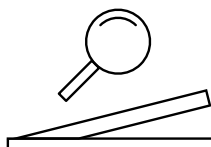

Removibile ed ispezionabile/Removable for ease of inspection/Repositionnable et permettant inspection et maintenance/Abnehmbar und kontrollierbar/Verwijderbaar en inspecteerbaar/Removible e inspeccionable

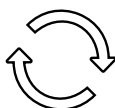

Riutilizzabile/Can be reused/Réutilisable/Wiederverwendbar/Herbruikbaar/Reutilizable



Ingelivo ed ignifugo/Frost proof and fireproof/Ingélif et ignifuge/Frostsicher und feuerfest/Vriesbestendig en vuurvast/Resistente al hielo y al fuego

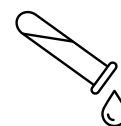

Inattaccabile dagli acidi/Not affected by acids/Inattaquable aux acides/Säurebeständig/Onaantastbaar door zuren/Inatacable por los ácidos



Ecologico/Eco friendly/Écologique/Umweltfreundlich/Ecológico



# OUT2.0 Contemporary

V2  
Slight



V3  
Moderate



V4  
Substantial



## Block

V3



Cinder 90x90/36"x36" R OUT2.0 MJ95

## Fornace

V3



Rosato 90x90/36"x36" R OUT 2.0 NQ26

V3



Zafferano 90x90/36"x36" R OUT 2.0 NQ27

## Mold

V3



Cinder 90x90/36"x36" R OUT2.0 MJ94

## Plain

V3

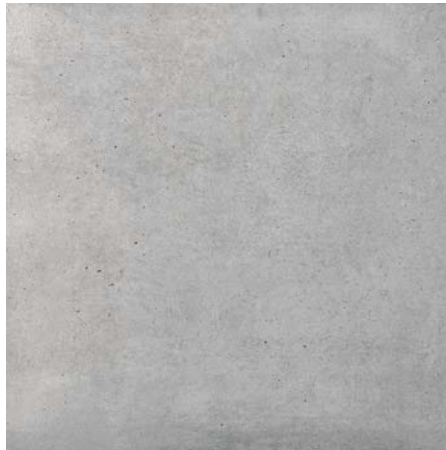

Cinder 90x90/36"x36" R OUT2.0 MJ93

# Plant

V4



Ash 40x120/16"x48" R OUT2.0 MH91

V4



Rope 40x120/16"x48" R OUT2.0 MZ46

Mold Cinder OUT2.0 90x90/36"x36" R



# OUT2.0 Contemporary

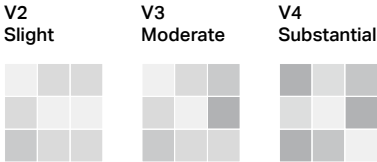

## Risseu



Chiaro      90x90/36"x36" R OUT2.0      NQ24



Scuro      90x90/36"x36" R OUT2.0      NQ25

## Wide



Carbon Strutt.      60x60/24"x24" R OUT2.0      LJ02



Steel Strutt.      60x60/24"x24" R OUT2.0      LJ01

# OUT2.0 Woods

OUT2.0  
322/323

## Larix

V3



Natural 60x60/24"x24" R OUT2.0 LQ02

V3



Sun 60x60/24"x24" R OUT2.0 LQ04

V3



Shade 60x60/24"x24" R OUT2.0 LQ03

V3



Natural 40x120/16"x48" R OUT2.0 MI58

V3



Sun 40x120/16"x48" R OUT2.0 MI59

Larix Natural OUT2.0 40x120/16"x48" R



# OUT2.0 Stones

V2  
Slight

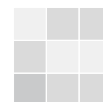

V3  
Moderate

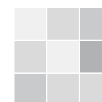

V4  
Substantial



## Blue Emotion

V4



**Scié Grey** 60x60/24"x24" R OUT2.0 **ME39**

V3

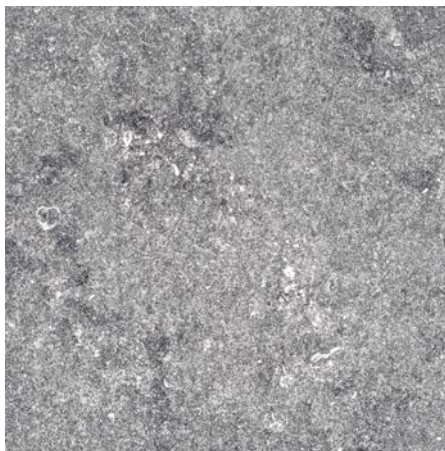

**Flammé Grey** 60x60/24"x24" R OUT2.0 **MC56**

V3



**Flammé Blue** 90x90/36"x36" R OUT2.0 **MT63**  
60x90/24"x36" R OUT2.0 **NH58**  
60x60/24"x24" R OUT2.0 **MC55**

V3

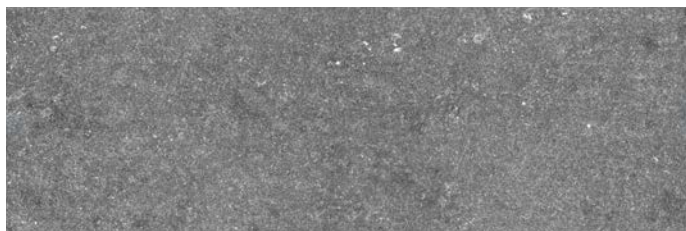

**Flammé Blue** 40x120/16"x48" R OUT2.0 **MI48**

Blue Emotion Scié Grey OUT2.0 60x60/24"x24" R



# Bluetech

V2



Design 60x60/24"x24" R OUT2.0 LG92

V2

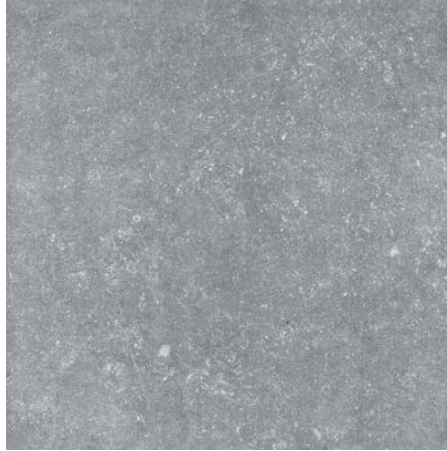

Vintage Plain 90x90/36"x36" R OUT2.0 MT62  
60x90/24"x36" R OUT2.0 NH59  
45x90/18"x36" R OUT2.0 LP23  
60x60/24"x24" R OUT2.0 LC63

V2



Vintage Charbon 45x90/18"x36" R OUT2.0 LP24  
60x60/24"x24" R OUT2.0 LH28

V2



Vintage Plain 40x120/16"x48" R OUT2.0 MI49

# Essence

V2



Perle 60x60/24"x24" R OUT2.0 NR92

V2



Avane 60x60/24"x24" R OUT2.0 NR91

# OUT2.0 Stones

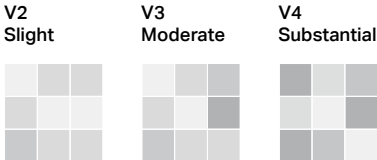

## Gaja



Grey 90x90/36"x36" R OUT2.0 MZ49  
60x60/24"x24" R OUT2.0 MZ47



Smoke 90x90/36"x36" R OUT2.0 MZ50  
60x60/24"x24" R OUT2.0 MZ48

## Petrae



Savoie Ash 60x60/24"x24" R OUT2.0 MC64



Barge Grigio 60x60/24"x24" R OUT2.0 LG98



Savoie Ash 40x120/16"x48" R OUT2.0 MH90

## Pietre di Borgogna

V3



Diamante Strutt. 60x60/24"x24" R OUT2.0 LG95

V3



Sabbia Strutt. 60x60/24"x24" R OUT2.0 LG96

V3



Grigia Anticata 60x60/24"x24" R OUT2.0 LU50

Petrae Savoie Ash OUT2.0 60x60/24"x24" R — Savoie Ash OUT2.0 30x60/12"x24" R





# OUT2.0 Stones

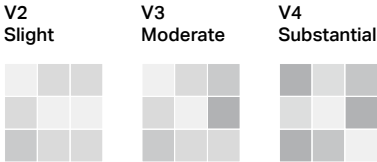

## Pietra di Cembra



**Grigio** 90x90/36"x36" R OUT 2.0 NP86  
45x90/18"x36" R OUT 2.0 NR02



**Naturale** 90x90/36"x36" R OUT 2.0 NP87  
45x90/18"x36" R OUT 2.0 NR03



**Ruggine** 90x90/36"x36" R OUT 2.0 NP88  
45x90/18"x36" R OUT 2.0 NR04



**Set Grigio 90x90/36"x36" R OUT2.0** NQ82



**Set Naturale 90x90/36"x36" R OUT2.0** NQ83



**Set Ruggine 90x90/36"x36" R OUT 2.0** NP84



**Coda di Pavone Mix R OUT 2.0** NQ80



**Arco Mix R OUT 2.0** NQ81

# Tune

V3



**Rock**      **90x90/36"x36" R OUT2.0**      **NA08**  
                  **60x90/24"x36" R OUT2.0**      **NH51**  
                  **60x60/24"x24" R OUT2.0**      **NH55**

V3



**Lava**      **90x90/36"x36" R OUT2.0**      **NA07**  
                  **60x90/24"x36" R OUT2.0**      **NH50**  
                  **60x60/24"x24" R OUT2.0**      **NH54**

V3



**Desert**      **90x90/36"x36" R OUT2.0**      **NH52**  
                  **60x90/24"x36" R OUT2.0**      **NH49**  
                  **60x60/24"x24" R OUT2.0**      **NH53**

## Imballi/Packing/Emballage/Verpackungseinheiten/Verpakking/Embalajes

	pcs x box	m <sup>2</sup> / m x box	kg x Box	box x pallet	m <sup>2</sup> / m x pallet	kg x pallet
<b>40x120/16"x48" OUT2.0</b>	2	0,9600	41,50	24	23,04	996,00
<b>90x90/36"x36" OUT2.0</b>	1	0,8100	37,60	18	14,58	676,80
<b>60x90/24"x36" OUT2.0</b>	2	1,0800	48,50	18	19,44	873,00
<b>45x90/18"x36" OUT2.0</b>	2	0,8100	37,00	27	21,87	999,00
<b>60x60/24"x24" OUT2.0</b>	2	0,7200	32,40	30	21,60	972,00
<b>Set 90x90/36"x36" OUT2.0</b>	1	0,8100	37,60	18	14,58	676,80
<b>Coda di Pavone Mix OUT2.0</b>	1	0,4900	14,15	16	7,84	226,40
<b>Arco Mix OUT2.0</b>	1	0,5800	18,00	16	9,28	288,00

# OUT2.0

Pezzi speciali/Trim tiles/Pieces speciales/Formteile/Speciale delen/Piezas especiales

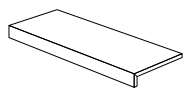

**Gradino OUT2.0**  
33x120/13"x48"  
33x90/13"x36"  
30x60/12"x24"  
15x60/6x24"



**Gradino Ang. OUT2.0**  
33x33/13"x13"  
30x30/12"x12"  
15x15/6"x6"

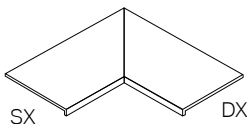

**Gradino Ang. Int Dx/Sx OUT2.0**  
33x120/13"x48"  
33x90/13"x36"  
30x60/12"x24"  
15x60/6x24"

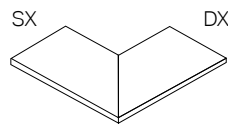

**Gradino Ang. Ext Dx/Sx OUT2.0**  
33x120/13"x48"  
33x90/13"x36"  
30x60/12"x24"  
15x60/6x24"

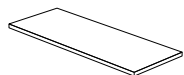

**Bordo OUT2.0**  
30x120/12"x48"  
30x90/12"x36"  
30x60/12"x24"  
15x60/6x24"

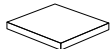

**Bordo Ang. OUT2.0**  
30x30/12"x12"  
15x15/6"x6"

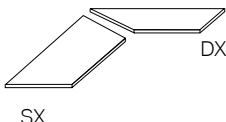

**Bordo Ang. Int Dx/Sx OUT2.0**  
30x120/12"x48"  
30x90/12"x36"  
30x60/12"x24"  
15x60/6x24"

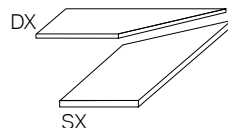

**Bordo Ang. Ext Dx/Sx OUT2.0**  
30x120/12"x48"  
30x90/12"x36"  
30x60/12"x24"  
15x60/6x24"

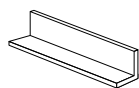

**Elemento L OUT2.0**  
15x90/6"x36"  
15x60/6x24"

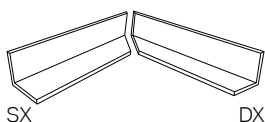

**Ang. L Int Dx/Sx OUT2.0**  
15x90/6"x36"  
15x60/6x24"

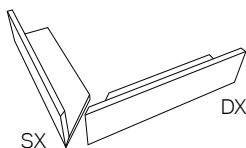

**Ang. L Ext Dx/Sx OUT2.0**  
15x90/6"x36"  
15x60/6x24"

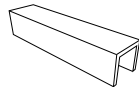

**Elemento U OUT2.0**  
15x90/6"x36"  
15x60/6x24"

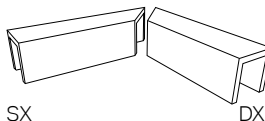

**Ang. U Dx/Sx OUT2.0**  
15x90/6"x36"  
15x60/6x24"

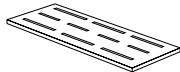

**Griglia OUT2.0**  
20x90/8"x36"  
20x60/8"x24"  
15x90/6"x36"  
15x60/6"x24"

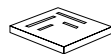

**Griglia Ang. OUT2.0**  
20x20/8"x8"  
15x15/6"x6"

**Poesia Grigia Anticata OUT2.0 60x60/24"x24" R — Gradino 30x60/12"x24" R — Gradino Angolare 30x30/12"x12" R**



**Plain Cinder 90x90/36"x36" OUT2.0 — Cinder Griglia 20x90/8"x36" OUT2.0 — Cinder Griglia Angolo 20x20/8"x8" OUT2.0 —  
Gradino 33x90/13"x36" OUT2.0 — Gradino Angolo DX/SX 33x90/13"x36" OUT2.0**



# OUT2.0 Installation

Modalità di posa/Methods of installation/Types de pose/  
Art der verlegung/Plaatsingsschema's/Formas de colocación

Posa sopraelevata con supporti/Raised flooring with supports/Pose surélevée sur plots/Verlegung als doppelboden mit trägern und stützen/Verhoogde vloeren met tegeldragers/Colocación sobre elevada con soportes



Posa sopraelevata con sistema Stage/ Raised flooring with Stage system/Pose surélevéesur système Stage/Werlegung auf gestockteem boden mit Stage/Verhoogde Vloeren met draagsysteem/Colocación sobre elevada con sistema Stage



Posa diretta su ghiaia e terreno/Directly on soil and gravel/Pose directe sur lit de gravier et sur terre battue/Direkte verlegung auf kies oder erde/Directe plaatsing op kiezel en grond/Colocación directa sobre grava y terreno



Posa tradizionale con collante/Traditional adhesive systems/Pose scellée sur chape/Herkömmliche verlegung mit kleber/Reguliere plaatsing met kleefmiddel/Colocación tradicional con cola



# OUT2.0 No-Lift System

OUT2.0  
332/333

Il "sistema anti-sollevamento" è studiato appositamente per risolvere il problema del sollevamento delle piastre di pavimentazione in esterno. Il sistema è costituito da una clip metallica che viene inserita all'interno della speciale aletta distanziatrice della testa del supporto e ha la funzione di ancorare la testa alla piastra di pavimentazione, senza l'utilizzo di collanti o viti. Il sistema è stato concepito per essere invisibile, ponendo grande attenzione all'impatto estetico finale. Le piastre usate per questo tipo di sistema devono essere preventivamente fresate nello spessore dei 4 angoli per accogliere la clip (la fessura è minima).

The "no-lift system" is specifically designed to solve the problem of the lifting of flooring plates outdoor. The system consists of a metal clip that is inserted inside the spacer of the support's head and has the function of anchoring the head to the paving plate, without using glues or screws. The system has been conceived to be invisible, paying great attention to the final aesthetic impact. The plates used for this type of system must be previously milled in the 4 corners to accommodate the clips (the fissure is tiny).

Le "système anti-soulèvement" est conçu expressément pour résoudre le problème du soulèvement des dalles de revêtement de sol à l'extérieur. Le système se constitue d'un clip métallique qui est introduit à l'intérieur de l'ailette d'écartement de la tête du support ayant la fonction d'ancrer la tête à la dalle de revêtement, sans recourir aux colles ou aux vis. Le système a été conçu pour être invisible, en posant une grande attention à l'impact esthétique final. Les dalles utilisées pour ce type de système doivent être préalablement fraisées dans l'épaisseur des 4 angles pour pouvoir loger les clips (la fissure est minimum).

Das "System gegen Plattenabhebung" wurde eigens dafür entwickelt, um das Problem der Abhebung der Platten im Außenbereich zu vermeiden. Das System besteht aus einer Metallklammer, welche in eine eigens dafür vorgesehene Abstandshalterung des Trägerkopfes eingeführt wird und die Funktion erfüllt, den Kopf des Stelzenlagers ohne Kleber, oder Schrauben, mit der Bodenplatte zu verbinden. Das System gegen Plattenabhebung wurde so entwickelt, dass es für das Auge des Betrachters unsichtbar ist. Bei Anwendung dieses Systems müssen die Platten seitlich an den vier Ecken eingefräst werden um die Metallklammern aufnehmen zu können (der Einschnitt ist minimal).

Het systeem, dat omhoogkomen van tegels voorkomt, is speciaal ontworpen om het probleem op te lossen van omhoogkomende buitentegels. Het systeem bestaat uit een metalen clip die in de speciale afstandslippen aan de kop van de tegeldrager wordt geplaatst en heeft de functie om de kop, zonder gebruik te maken van lijm of schroeven, aan de tegel te verankeren. Het systeem is met veel aandacht voor het uiteindelijke esthetische effect zodanig ontworpen dat het onzichtbaar is. Van de tegels die voor dit type systeem worden gebruikt, moeten vooraf de 4 hoeken worden gefreesd om de clips te kunnen plaatsen (de gleuf is minimaal).

El «sistema antilevantamiento» está diseñado específicamente para resolver el problema de lasras de pavimentación exteriores que se levantan. El sistema consiste en un clip metálico que se inserta dentro de la aleta espaciadora especial en la cabeza de soporte y su función de anclar la cabeza a la lastra de pavimentación sin el uso de adhesivos ni tornillos. El sistema ha sido diseñado para ser invisible, prestando gran atención al impacto estético final. Las lastras utilizadas para este tipo de sistema deben ser previamente fresadas en el espesor de las 4 esquinas para acomodar los clips (la ranura es mínima).



Alette per fissaggio  
Clip wings for fixing clips  
Ailettes pour le fixage clip  
Metallklammern zum fixieren  
Bevestigingslippen  
Aletas para la fijación

No-LIFT CLIP  
Sezione a "T"  
"T" section  
Section à "T"  
Die T-Ausführung  
T-sectie  
Sección a "T"



No-LIFT CLIP  
Sezione a "L"  
"L" section  
Section à "L"  
Die L-Ausführung  
L-sectie  
Sección a "L"

# OUT2.0 Stage

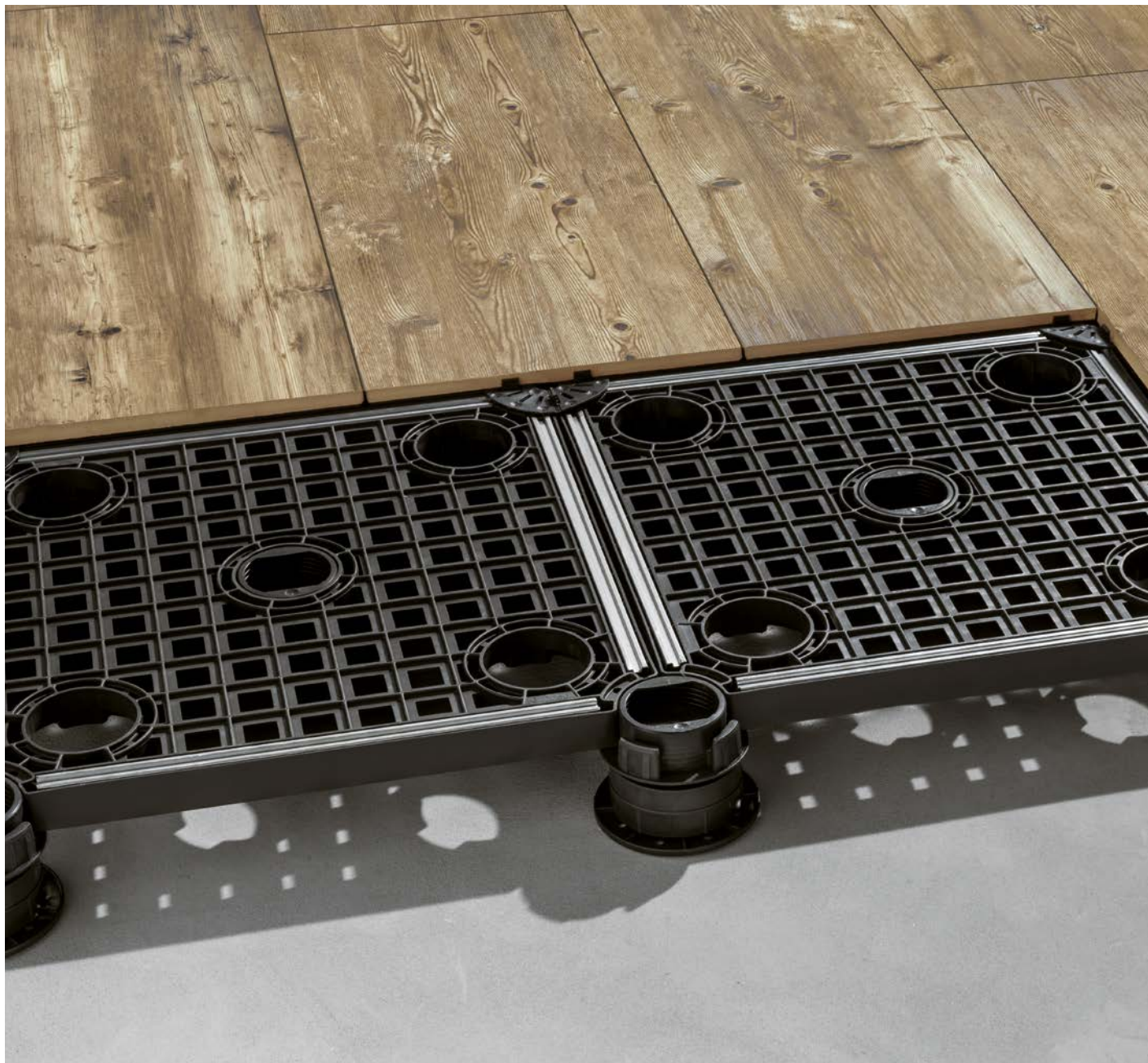

Il nuovo sistema per la posa sopraelevata OUT2.0 STAGE è composto da una struttura portante in polipropilene abbinata al grès porcellanato Refin.

OUT2.0 STAGE assicura la massima libertà progettuale, consentendo la posa di molteplici formati e schemi di posa, e garantisce i massimi standard di sicurezza, senza l'applicazione di alcun sistema di rinforzo sul retro delle lastre.

The new system for raised flooring OUT2.0 STAGE is composed of a load-bearing structure in polypropylene combined with Refin porcelain stoneware tiles.

OUT2.0 STAGE ensures the maximum design freedom, allowing many sizes and laying scheme, and guarantees the maximum safety standards without the application of any reinforcement system on the backside of the slabs.

Le nouveau système pour la pose surélevée OUT2.0 STAGE est composé d'une structure porteuse en polypropylène associée au grès cérame Refin.

OUT2.0 STAGE assure la plus grande liberté de conception, en permettant la pose de multiples formats et d'innombrables schémas de pose, et garantit les plus hauts standards de sécurité, ceci sans aucun système de renfort à appliquer au dos des dalles.

Das neue System für die Verlegung von OUT2.0 STAGE als Doppelboden besteht aus einer Polypropylen-Tragstruktur sowie aus Refin-Feinsteinzeug.

OUT2.0 STAGE garantiert die höchste Flexibilität in der Planung und erlaubt die Verlegung zahlreicher Formate und Verlegemuster, sowie höchste Sicherheit ohne jegliches Verstärkungssystem für die Fliesenrückseite.

Het nieuwe legstelsel met tegeldragers OUT2.0 STAGE bestaat uit een polypropyleen draagstructuur gecombineerd met Refin porseleinsgres.

OUT2.0 STAGE biedt maximale ontwerpvrijheid doordat meerdere formaten en legschema's kunnen worden gebruikt, en verzekert maximale veiligheidsstandaards zonder toepassing van enig versterkingssysteem op de achterkant van de platen.

El nuevo sistema para la colocación elevada OUT2.0 STAGE consiste en una estructura portante de polipropileno combinada con el grés porcelánico Refin.

OUT2.0 STAGE asegura la máxima libertad de diseño, lo que permite la instalación de múltiples formatos y diagramas de colocación, y garantiza los máximos estándares de seguridad sin la necesidad de colocar ningún sistema de refuerzo en la cara interior de las placas.

System components

	← Separatore di posa/Separator for laying/Croisillon de pose/ Abstandshalter für die verlegung/Bovenplaat/Separador de capas
	← Inserti in acciaio/Steel stringers/Inserts en acier/ Stahleinschlüsse/Stalen inzetstuk/Encastres de acero
	← Modulo di posa/Laying module/Module de pose/ Verlegemodul/Draagmodule/Diagrama de colocación
	← Supporto di fissaggio/Fixing support/Support de fixation/ Befestigungshalter/Bevestigingssteun/Soporte de fijación
	← Regolazione supporto/Support adjustment/Réglage support/ Trägerregulierung/Verstelbare steun/Ajuste soporte
<p data-bbox="161 1140 368 1204"><b>OPTIONAL COMPONENTS</b></p>	← H. 25 mm Distanziale sopraelevazione/Spacer for raising/ Plot de surélévation/Abstandshalter für die aufstockung/ Afstandhouder/Espaciador de elevación
	← H. 50 mm Distanziale sopraelevazione/Spacer for raising/ Plot de surélévation/Abstandshalter für die aufstockung / Afstandhouder/Espaciador de elevación
	← Base supporto/Support base/Base support/Trägerbasis/ Basisplaat/Base de apoyo

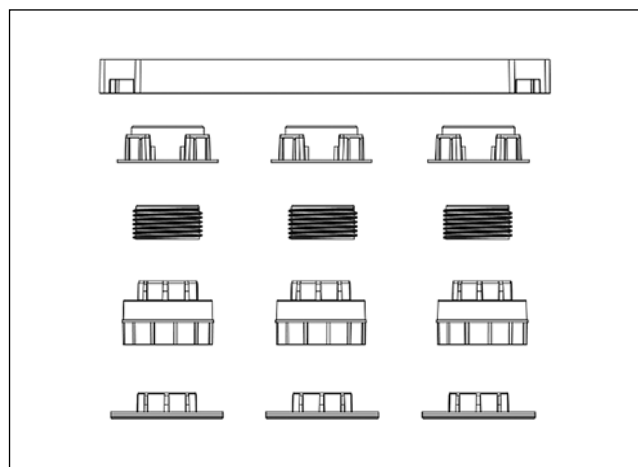



# OUT2.0 Stage

## System components

### Inserti in acciaio/Steel stringers/Inserts en acier/ Stahleinleger/Stalen inzetstuk/Encastres de acero

2 / 60x60,75x75, 90x90, 45x90cm

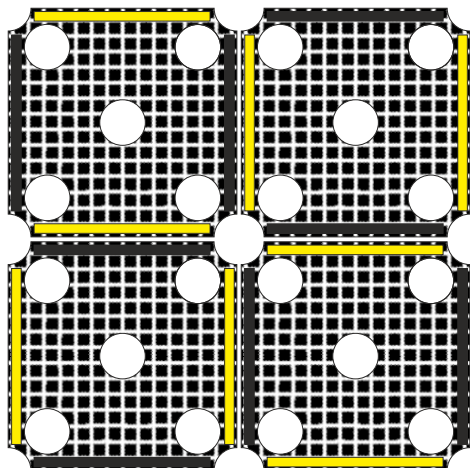

4 / 40x120cm

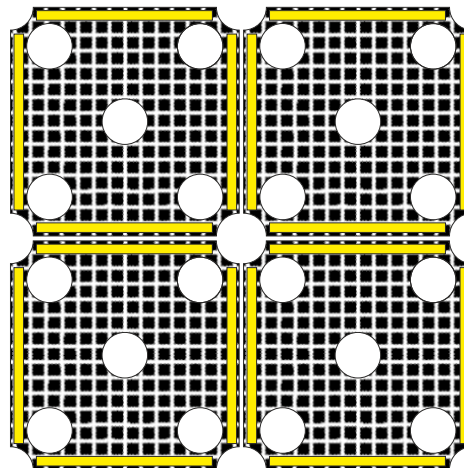

Gli inserti in acciaio (articolo 5) sono necessari nelle seguenti quantità: 2 per ogni modulo, a posa alterna, per i formati 60x60, 90x90, 45x90cm (30 inserti / 5,4mq) e 4 per ogni modulo per la posa del formato 40x120 (60 inserti / 5,4mq).

The steel stringers (item 5) are necessary in the following quantities: 2 stringers for each module (alternate laying) when tiles measure 60x60, 90x90, 45x90cm (30 stringers / 5,4 SQ.M., 4 stringers to lay tiles size 40x120cm (60 stringers / 5,4 SQ.M.).

Les inserts en acier (article 5) sont nécessaires dans les quantités suivantes: 2 pour chaque module, pose alternée, pour la pose des formats 60x60, 90x90 et 45x90 cm (30 inserts/5,4 m<sup>2</sup>) et 4 pour chaque module pour la pose du format 40x120 (60 inserts / 5,4 m<sup>2</sup>).

Die Stahleinleger (Artikel 5) werden in folgender Menge benötigt: für die Formate 60x60, 90x90, 45x90 cm 2 Stck. für jedes Modul, wie abgebildet positioniert (30 Einleger/5,4 qm), und bei Verlegung des Formats 40x120 4 Stck. für jedes Modul (60 Einleger/5,4 qm).

Van de stalen inzetstukken (artikel 5) zijn de volgende aantallen benodigd: 2 per draagmodule, wisselend gelegd, bij de formaten 60x60, 90x90, 45x90cm (30 inzetstukken / 5,4m<sup>2</sup>) en 4 per draagmodule bij formaat 40x120 (60 inzetstukken / 5,4m<sup>2</sup>).

Los encastres de acero (artículo 5) son necesarios en las siguientes cantidades: 2 para cada diagrama de colocación alternada, (tipo ajedrez) para los formatos 60x60, 90x90, 45x90cm (30 encastres / 5,4 m<sup>2</sup>) y 4 para cada diagrama, para la colocación del formato 40x120 (60 encastres / 5,4 m<sup>2</sup>).

### Chiave regolazione/Adjustment key/Clé de réglage/ Schlüssel zur regulierung/Afstelsleutel/Llave de regulación



Code  
MS60



OUT 2.0 STAGE può essere acquistato solo a scatole intere.

Ognuno degli imballi contiene i componenti necessari alla posa di **5,4mq di superficie (unità minima di vendita)**.

OUT 2.0 STAGE nasce per la posa sopraelevata in esterno di gres porcellanato e deve essere commercializzato ed utilizzato come da specifiche tecniche.

**Il sistema può essere acquistato solo in abbinamento a piastrelle refin OUT2.0.**

Non è consentita la vendita del sistema di posa né l'utilizzo della griglia in plastica superiore se non in combinazione con i supporti regolabili del sistema stesso.

OUT2.0 STAGE can only be purchased in whole boxes.

Each of the packs contains the components necessary for laying **5,4 SQ.M. of surface (minimum sales quantity)**. The OUT2.0 STAGE system is conceived for raised outdoor floors in porcelain stoneware and must be sold and used as per the technical specifications.

**The system can only be purchased together with Refin OUT2.0 tiles.**

The upper plastic grid must not be sold or used unless in combination with the adjustable supports of the system itself.

L'achat d'OUT 2.0 STAGE s'effectue uniquement par boîte unitaire. Chaque boîte contient les éléments nécessaires pour la couverture d'une surface de **5,4 m<sup>2</sup> (unité minimum de vente)**.

OUT 2.0 STAGE est conçu pour une pose surélevée du grès cérame en extérieur et doit être commercialisé et utilisé selon les spécifications techniques.

**Ce système ne peut être acheté qu'en association aux carreaux Refin OUT2.0.**

La vente du système de pose, ou l'utilisation de la grille en plastique supérieure, n'est autorisée qu'en combinaison avec les supports réglables du système.

OUT 2.0 STAGE wird kartonweise verkauft.

Jede Packung enthält Komponenten für die Verlegung einer Fläche von **5,4 qm Größe (Mindest-Verkaufseinheit)**.

OUT 2.0 STAGE wurde für die Verlegung von Feinsteinzeug als Doppelboden im Aussenbereich entwickelt und wird nach bestimmter Vertriebspolitik und technischer Spezifikationen vertrieben.

**Das System ist ausschliesslich inklusive der Fliesen von REFIN OUT2.0 (20mm stark) erhältlich.**

Sowohl das Verlegesystem als auch das obere Kunststoffraster, können ausschliesslich mit den verstellbaren Träger des Systems verkauft werden.

OUT 2.0 STAGE kan uitsluitend per doos worden verkocht.

Elke doos bevat alle benodigde onderdelen om **5,4 m<sup>2</sup> (minimale verkoopenheid) te betegelen**.

OUT 2.0 STAGE is ontwikkeld voor het leggen van porseleingres-tegels op tegeldraggers buitenshuis, en moet worden verkocht en gebruikt volgens de technische specificaties.

**Het systeem OUT 2.0 STAGE kan uitsluitend in combinatie met tegels Refin OUT2.0 worden gekocht.**

Het draagsysteem mag uitsluitend worden gebruikt in combinatie met de verstelbare steunen van dit draagsysteem.

OUT 2.0 STAGE se puede comprar únicamente en cajas completas.

En cada una de las cajas se encuentran los componentes necesarios para instalar **5,4m<sup>2</sup> de superficie (unidad mínima de venta)**.









OUT 2.0 STAGE está diseñado para la instalación elevada de gres porcelánico en exteriores, además tiene que comercializarse y utilizarse conforme a las especificaciones técnicas.

**El sistema se puede comprar sólo en combinación con las baldosas Refin OUT2.0.**

No está permitida la venta del sistema de colocación ni la utilización de la rejilla de plástico superior, a no ser que se combine con los soportes regulables del mismo sistema.

# OUT2.0

## POSA A SECCO SU SISTEMA STAGE/ DRY INSTALLATION ON STAGE SYSTEM

System Components	Code	Pcs x Box	Kg x Box	m <sup>2</sup> x Box	Box x Pallet
<b>1</b> Modulo di posa/Laying module/Module de pose/Verlegemodul/ Draagmodule/Diagrama de colocación 	<b>MS55</b>	15	40,2	5,4	2
<b>2</b> Kit supporto/Kit support/Kit support/ Trägersatz/Draagkit/Juego de soporte (A+B+C+D) <b>A</b>  <b>38 Pcs</b> Base supporto/Support base/Base support/ Trägerbasis/Basisplaat/Base de apoyo + <b>B</b>  <b>38 Pcs</b> Regolazione supporto/Support adjustment/ Réglage support/Trägerregulierung/Verstellbare steu/ Ajuste soporte + <b>C</b>  <b>38 Pcs</b> Supporto di fissaggio/Fixing support/Support de fixation/Befestigungshalter/Bevestigingssteun/ Soporte de fijación + <b>D</b>  <b>33 Pcs</b> Separatore di posa/Separator for laying/ Croisillon de pose/Abstandhalter für die verlegung/ Bovenplaat/Separator de capas	<b>MS56</b>	1	9,7	5,4	9
<b>3</b>  <b>H. 25 mm</b> - Distanziale sopraelevazione/Spacer for raising/Plot de surélévation/Abstandshalter für die aufstockung/Afstandhouder/Espaciador de elevación	<b>MS57</b>	38	3,2	5,4	40
<b>4</b>  <b>H. 50 mm</b> - Distanziale sopraelevazione/Spacer for raising/Plot de surélévation/Abstandshalter für die aufstockung/Afstandhouder/Espaciador de elevación	<b>MS58</b>	38	5,6	5,4	20
<b>5</b>  Inserti in acciaio/Steel stringers/Inserts en acier/ Stahleinschlüsse/Stalen inzetstuk/Encastres de acero	<b>MW34</b>	30	10	2,7 (40x120) 5,4 (60x60 - 75x75 - 90x90 - 45x90)	
 Chiave regolazione/Adjustment key/Clé de réglage/ Schlüssel zur regulierung/Afstelsleutel/Llave de regulación	<b>MS60</b>	1			

Gli articoli 1 e 2 sono necessari per la posa di OUT2.0 STAGE con altezza da 5 a 7cm + lastra in gres.

A seconda delle crescenti altezze di posa si aggiungono gli articoli 3 e 4 in quantità variabile.

Items 1 and 2 are necessary for laying the OUT2.0 STAGE configuration with height from 5 to 7cm + stone-ware slab.

As the laying heights grow, items 3 and 4 are added in a variable amount.

Les articles 1 et 2 sont nécessaires pour la pose d'OUT2.0 STAGE à une hauteur de 5 à 7 cm + carreau en grès.

Selon l'augmentation de la hauteur de pose, il faudra ajouter les articles 3 et 4, en nombre variable.

Die Artikel 1 und 2 sind notwendig für die Installation von OUT2.0 STAGE mit einer Höhe von 5 bis 7 cm plus der Feinsteinzeug-Platte.

Artikel 3 und 4 werden angewendet, um die Aufbauhöhe je nach Bedarf graduell zu erhöhen.

De artikelen 1 en 2 zijn benodigd voor het leggen van OUT2.0 STAGE op een hoogte van 5 tot 7cm + gresplaat.

Naar gelang de hoogte toeneemt, worden de artikelen 3 en 4 in variabele hoeveelheden toegevoegd.

Los artículos 1 y 2 son necesarios para la colocación de OUT2.0 STAGE con altura de 5 a 7cm + placa de gres.

Dependiendo de las crecientes alturas de colocación, se añaden los artículos 3 y 4 en cantidades variables.

## POSA A SECCO SU SUPPORTI/ DRY INSTALLATION ON SUPPORTS

	System Components	Height	Code
	Supporto ad altezza fissa/ Fixed support/ Support fixes/ Fixer Träger/ Tegeldrager vast/ Soporte de altura fija	15 mm	<b>L764</b>
	STAR T Supporto ad altezza regolabile/ Adjustable support/ Support réglables/ Regulierbarer Träger/ Verstellbare tegeldrager/ Soporte de altura ajustable	10 - 15 mm	<b>L764</b>
	STAR B Prolunga per supporto regolabile STAR T/ Extension for adjustable support STAR T/ Extension pour support réglable STAR T/ Verlängerung für regulierbaren Träger STAR T/ Verhoging voor verstellbare tegeldrager/ Extención para soporte de altura ajustable STAR T	5 mm	<b>LO54</b>
	Supporto ad altezza regolabile/ Adjustable support/ Support réglables/ Regulierbarer Träger/ Verstellbare tegeldrager/ Soporte de altura ajustable	25 - 40 mm	<b>L765</b>
	Supporto ad altezza regolabile/ Adjustable support/ Support réglables/ Regulierbarer Träger/ Verstellbare tegeldrager/ Soporte de altura ajustable	40-70 mm	<b>L766</b>
	Supporto regolabile con testa autolivellante/ Self-leveling support/ Supports auto-nivelants/ Selbstregulierender Träger/ Verstellbare tegeldrager met –zelfregulerende Kop/ Soporte de autonivelación	37,5 - 50 mm	<b>L767</b>
	Supporto regolabile con testa autolivellante/ Self-leveling support/ Supports auto-nivelants/ Selbstregulierender Träger/ Verstellbare tegeldrager met –zelfregulerende Kop/ Soporte de autonivelación	50 - 75 mm	<b>L768</b>
	Chiave di regolazione/ Adjustment key/ Clé de réglage/ Regulierungsschlüssel/ Afstelsleutel/ Llave de ajuste		<b>LC16</b>
	NO-LIFT Supporto autolivellante anti-sollevamento/ No-lift self-leveling support/ Supports auto-nivelants anti-soulèvement/ Selbstnivellierender, gegen Abheben sicherer Untergrund/ Zelfnivellerende, omhoogkomen voorkomende steun/ Soporte autonivelador anti-elevación	30 - 40 mm	<b>NH14</b>
	NO-LIFT Supporto autolivellante anti-sollevamento/ No-lift self-leveling support/ Supports auto-nivelants anti-soulèvement/ Selbstnivellierender, gegen Abheben sicherer Untergrund/ Zelfnivellerende, omhoogkomen voorkomende steun/ Soporte autonivelador anti-elevación	39,5 - 52 mm	<b>NH15</b>
	NO-LIFT Supporto autolivellante anti-sollevamento/ No-lift self-leveling support/ Supports auto-nivelants anti-soulèvement/ Selbstnivellierender, gegen Abheben sicherer Untergrund/ Zelfnivellerende, omhoogkomen voorkomende steun/ Soporte autonivelador anti-elevación	52 - 77 mm	<b>NH16</b>
	No-LIFT CLIP Sezione a "T"/ "T" section/ Section à "T"/ Die T-Ausführung/ T-sectie/ Sección a "T"		<b>NH17</b>
	No-LIFT CLIP Sezione a "L"/ "L" section/ Section à "L"/ Die L-Ausführung/ L-sectie/ Sección a "L"		<b>NH18</b>

# OUT2.0



## RACCOMANDAZIONI PER LA POSA A SECCO/ RECOMENDATIONS FOR DRY INSTALLATION

Istruzioni per committenti e progettisti/Instructions for project engineers and customers/  
Consignes pour donneurs d'ordres et concepteurs/Anweisungen für Auftraggeber und Projektleiter/Instruities  
voor opdrachtgevers en ontwerpers/Instrucciones para promotores y proyectistas

Quando l'applicazione delle lastre in 20 mm. prevede l'utilizzo del prodotto ceramico in termini strutturali, si raccomanda al progettista e/o committente una attenta valutazione dei requisiti del progetto in relazione alle caratteristiche tecniche delle lastre. In particolare, al fine di evitare il rischio di danni a persone o cose il produttore raccomanda:

→ Se l'applicazione prevede la posa sopraelevata, tenendo conto che una piastrella potrebbe rompersi in seguito alla caduta su di essa di un corpo pesante, verificare anticipatamente la destinazione d'uso specifica e attenersi alla tabella istruzioni di posa sopraelevata di seguito riportata ove, in determinate condizioni, è prevista l'applicazione di un rin-

If the application of the 20 mm slabs foresees the ceramic product used in structural installations, the project engineer and/or customer must carefully assess the project requirements with regard to the technical specifications of the slabs. To prevent the risk of damage or injury, the manufacturer recommends:

→ With regard to a raised floor installation a ceramic slab may fracture on impact if a heavy object falls on it from any significant height. Therefore the manufacturer recommends to check the specific intended use before starting the installation and to follow table for raised installation provided below. In certain conditions, reinforcing must be applied on the back of the slabs (mesh plus or

Lorsque la mise en œuvre de dalles de 20 mm prévoit l'utilisation du produit céramique en termes structurels, il est recommandé aux concepteurs, maîtres d'œuvre et/ou aux maîtres d'ouvrage de faire une évaluation scrupuleuse du cahier des charges du projet eu regard aux caractéristiques techniques des dalles. En particulier, afin d'éviter le risque de dommages aux personnes ou aux biens, le fabricant recommande: → Si la mise en œuvre prévoit une pose surélevée, en tenant compte qu'un carreau pourrait se casser suite à la chute d'un corps lourd, de vérifier en avance la destination d'usage spécifique et de se conformer au tableau d'instructions de pose sur élevée reproduit

Falls der Einsatz der 20 mm Platten eine Verwendung des keramischen Produkts als Bestandteil der Gebäudestruktur vorsieht, ist der Planer und/oder Auftraggeber angehalten, eine sorgfältige Prüfung der Voraussetzungen des Projekts in Bezug auf die technischen Eigenschaften der Platten vorzunehmen. Insbesondere zur Vermeidung der Gefahr von Personen- und Sachschäden, erteilt der Hersteller folgenden Hinweis:

→ Unter Berücksichtigung des Umstandes, dass die Fliese infolge eines schweren herabfallenden Gegenstandes zerbrechen könnte, muss im Falle einer Anwendung als Doppelboden im Voraus eine Prüfung des spezifi-

Wanneer de 20 mm dikke keramische platen fungeren als structurele componenten, bevelen wij de ontwerper en/of opdrachtgever aan aandachtig de eisen van het ontwerp te evalueren in functie van de technische eigenschappen van de platen. Zo maakt de fabrikant in het bijzonder de volgende aanbevelingen om de risico's voor schade aan personen of zaken te vermijden:

→ Indien plaatsing in verhoogde vloeren is vereist, en rekening houdend met het feit dat een tegel kan breken indien er een zwaar voorwerp op valt, moet men op voorhand de specifieke gebruiksbestemming controleren en moet de verder vermelde tabel met instructies voor plaatsing op verhoogde vloeren worden geres-

Si la aplicación de las losas de 20 mm prevé el uso del producto cerámico en términos estructurales, se recomienda al proyectista y/o promotor valorar minuciosamente los requisitos del proyecto en lo que respecta a las características técnicas de dichas losas. En particular, para evitar posibles daños a personas o cosas el fabricante recomienda:

→ Si la aplicación prevé la colocación sobreelevada, considerándose que una baldosa podría romperse al caérsele un objeto pesado, comprobar previamente el uso previsto y atenerse a la tabla "instrucciones de colocación sobreelevada" que se expone a continuación, en la que se especifica que en determinadas condiciones se prevé la aplica-

forzo sul retro della piastrina (rete plus o acciaio zincato) fornito dal produttore;  
→ Le pavimentazioni da esterno posate a secco in quota sono soggette all'azione del vento, con il rischio di sollevamento delle lastre. Il produttore raccomanda di far verificare l'idoneità del sistema di posa in quota da un tecnico abilitato in base alla normativa locale vigente ed alle condizioni d'uso, al fine di evitare il rischio di danni a persone e cose. Con riferimento alla pavimentazione posata in quota, con qualunque sistema di posa a secco, rispettare le specifiche normative e condizioni d'uso locali riguardanti, tra l'altro, a titolo esemplificativo, l'azione del vento, il carico strutturale, le azioni sismiche, ecc.  
Il mancato rispetto delle raccomandazioni sopra riportate può portare ad un utilizzo improprio del prodotto e causare eventualmente gravi danni a persone o cose.

galvanized steel sheet) supplied by the manufacturer.  
→ Outdoor pavings installed unglued above the ground level are subject to the action of the wind, with the risk, in some cases, of becoming airborne. The manufacturer recommends to require the assistance of a qualified professional in order to check the suitability of the installation system above the ground adopted, in accordance with the local laws and regulations and the conditions of use. Failure to do so could result in serious injury or property damage. With reference to any dry installation system of flooring above the ground level, the manufacturer recommends to comply with local regulations and conditions of use with regard to wind-load, loadbearing, seismic events, etc. Failure to comply with these recommendations may lead to improper use of the product and could cause serious damage or injury.

ci-après, où, dans des conditions déterminées, il est prévu de rajouter un renforcement sur le revers du carreau (double filet ou acier zingué), fourni par le fabricant.  
→ Les dallages extérieurs posés sans collage sont soumis à l'action du vent, avec le risque de soulèvement des plaques, notamment ceux posés aux étages d'un bâtiment. Le fabricant recommande de faire vérifier par un technicien qualifié la bonne adaptation du système de pose en étages avec la réglementation en vigueur et les conditions d'utilisation locales, afin d'éviter le risque de dommages aux personnes et aux biens. Concernant le dallage posé en étages, quelque soit le système de pose sans collage utilisé, e respecter les spécifications des normes et les conditions locales d'emploi, entre autre, à titre d'exemple, l'action du vent, le chargement structurel, les actions sismiques, etc. Le non respect des recommandations reproduites ci-dessus peut conduire à un usage improprie du produit et éventuellement causer de graves dommages aux personnes ou aux biens.

schen Einsatzbereichen erfolgen.  
Außerdem ist die nachfolgende Tabelle mit Verlegeanweisungen zu berücksichtigen, die unter bestimmten Bedingungen die Aufbringung einer Verstärkung auf der Rückseite der Fliese vorsieht (Netz Plus, oder verzinkter Stahl), welche vom Produzenten geliefert wird;  
→ Bodenbeläge die trocken im Außenbereich in der Höhe verlegt werden, unterliegen der Wirkung des Windes, wodurch die Gefahr besteht, dass die Platten aufgeworfen werden. Der Hersteller erteilt daher die Empfehlung, dass die Eignung des Systems für eine Verlegung in der Höhe durch einen zugelassenen Sachverständigen überprüft wird, wobei die lokal gültigen Vorschriften und Nutzungsbedingungen zu beachten sind, um die Gefahr von Personen- und Sachschäden zu vermeiden. Mit Bezug auf Bodenbeläge die trocken im Außenbereich in der Höhe verlegt werden, sind die spezifischen lokalen Vorschriften und Nutzungsbedingungen zu berücksichtigen, die unter anderem, wie zum Beispiel für die Wirkung des Windes, der strukturellen Belastung, der Wirkung von Erdbeben, etc., vorgesehen sind. Die Nichtberücksichtigung der oben genannten Anweisungen kann zu einer unsachgemäßen Verwendung des Produkts führen und eventuell schwerwiegende Personen- und Sachschäden verursachen.

pecteerd. Deze vermeldt de condities die de aanbrenging vereisen van een versterkende onderlaag op de onderkant van de tegel ("plus" net of verzinkt staal), geleverd door de fabrikant;  
→ Steeds met verwijzing naar systemen met verhoogde vloeren wordt benadrukt dat, met gebruik van gelijk droog plaatsingsstelsel, de specifieke plaatselijke normen en gebruikscondities moeten worden gerespecteerd, bijvoorbeeld voor wat betreft de invloed van wind, structurele belastingen, seismische activiteiten, enz.  
De niet naleving van bovenstaande aanbevelingen kan resulteren in het oneigenlijk gebruik van het product en kan ernstige schade berokkenen aan personen en zaken.

ción de un refuerzo en la parte posterior de la baldosa (red plus o acero galvanizado) suministrado por el fabricante;  
En relación con la pavimentación colocada en altura, respetar con cualquier sistema de colocación en seco las normativas específicas y las relativas condiciones de uso locales, entre las que destacamos por ejemplo la acción del viento, la carga estructural, las acciones sísmicas, etc.  
El incumplimiento de las recomendaciones arriba indicadas podría conllevar el uso incorrecto del producto y ocasionar posibles daños graves a personas o cosas.

Per dettagli sul prodotto in 20 mm. di spessore e sui relativi sistemi di posa ed, in particolare, per le raccomandazioni, accorgimenti, limitazioni di utilizzo e precauzioni in fase di posa, si raccomanda di prendere visione del catalogo OUT2.0 e del sito [www.refin.it](http://www.refin.it).

For further details on the 20 mm product and the installation systems, in particular for recommendations, restrictions of use, and precautions during installation, please refer to our website [www.refin.it](http://www.refin.it) and to the OUT2.0 catalogue.

Pour de plus amples détails sur les produits de 20 mm d'épaisseur et sur leurs systèmes de pose, et en particulier, pour les recommandations, mises à jour, limitations d'usage et précautions en phase de pose, veuillez prendre connaissance du catalogue OUT2.0 et du [www.refin.it](http://www.refin.it).

Für Details zum Produkt mit 20 mm Stärke und entsprechende Verlegesysteme, insbesondere hinsichtlich Hinweise und Anmerkungen, ungeschwächtungen und Vorsichtsmaßnahmen während der Verlegung, wird die Einsicht des Katalogs OUT2.0 und der Webseite [www.refin.it](http://www.refin.it) empfohlen.

Voor de details van het product met dikte 20 mm en de bijbehorende plaatsingschema's, en in het bijzonder voor de aanbevelingen, tips, gebruiksbepalingen en voorzorgsmaatregelen tijdens de plaatsingsfase wordt verwezen naar de catalogus van de lijn OUT2.0 en de site [www.refin.it](http://www.refin.it).

Para más detalles acerca del producto de 20 mm de espesor y de los relativos sistemas de colocación y, en particular, de las recomendaciones, cuidados, limitaciones de uso y precauciones en fase de colocación, se recomienda consultar el catálogo de la línea OUT2.0 y la web [www.refin.it](http://www.refin.it).

# OUT2.0

## RACCOMANDAZIONI PER LA POSA A SECCO/ RECOMENDATIONS FOR DRY INSTALLATION

Per tutti i mercati esclusi USA, Canada e Oceania/For all markets except USA, Canada and Oceania/  
Pour tous les marchés, à l'exception des USA, Canada et Océanie/Für alle Märkte ausgenommen USA,  
Kanada und Ozeanien

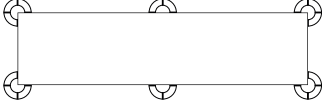
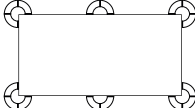
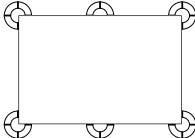
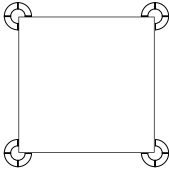
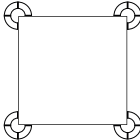
Formato/Size/Format/Format		fino a/Up to/jusqu'à/bis 2 cm	da/from/de/von 2 cm a/to/à/bis 10 cm	da/from/de/von 10 cm a/to/à/bis 30 cm
<b>cm 40x120</b> (nominale/rated/nominal/Nennmaße) 6 supporti per lastra/supports per slab/ vérins par plaque/Stützen pro Platte		<b>6 supporti/supports/ vérins/Stützen</b> → 7,0 pcs/m <sup>2</sup>	<b>6 supporti/supports/ vérins/Stützen</b> → 7,0 pcs/m <sup>2</sup>  + Doppia rete plus o foglio di acciaio galvanizzato/Fiber-Mesh <i>Plus</i> or galvanized steel sheet/Filet plus ou feuille en acier galvanisé/ Verzinkte Stahlfolie Oder Plus-Netz	<b>6 supporti/supports/ vérins/Stützen</b> → 7,0 pcs/m <sup>2</sup>  + Doppia rete plus o foglio di acciaio galvanizzato/Fiber-Mesh <i>Plus</i> or galvanized steel sheet/Filet plus ou feuille en acier galvanisé/ Verzinkte Stahlfolie Oder Plus-Netz
<b>cm 45x90</b> (nominale/rated/nominal/Nennmaße) 6 supporti per lastra/supports per slab/ vérins par plaque/Stützen pro Platte		<b>6 supporti/supports/ vérins/Stützen</b> → 6,0 pcs/m <sup>2</sup>	<b>6 supporti/supports/ vérins/Stützen</b> → 6,0 pcs/m <sup>2</sup>  + Doppia rete plus o foglio di acciaio galvanizzato/Fiber-Mesh <i>Plus</i> or galvanized steel sheet/Filet plus ou feuille en acier galvanisé/ Verzinkte Stahlfolie Oder Plus-Netz	<b>6 supporti/supports/ vérins/Stützen</b> → 6,0 pcs/m <sup>2</sup>  + Doppia rete plus o foglio di acciaio galvanizzato/Fiber-Mesh <i>Plus</i> or galvanized steel sheet/Filet plus ou feuille en acier galvanisé/ Verzinkte Stahlfolie Oder Plus-Netz
<b>cm 60x90</b> (nominale/rated/nominal/Nennmaße) 6 supporti per lastra/supports per slab/ vérins par plaque/Stützen pro Platte		<b>6 supporti/supports/ vérins/Stützen</b> → 6,0 pcs/m <sup>2</sup>	<b>6 supporti/supports/ vérins/Stützen</b> → 6,0 pcs/m <sup>2</sup>  + Doppia rete plus o foglio di acciaio galvanizzato/Fiber-Mesh <i>Plus</i> or galvanized steel sheet/Filet plus ou feuille en acier galvanisé/ Verzinkte Stahlfolie Oder Plus-Netz	<b>6 supporti/supports/ vérins/Stützen</b> → 6,0 pcs/m <sup>2</sup>  + Doppia rete plus o foglio di acciaio galvanizzato/Fiber-Mesh <i>Plus</i> or galvanized steel sheet/Filet plus ou feuille en acier galvanisé/ Verzinkte Stahlfolie Oder Plus-Netz
<b>cm 90x90</b> (nominale/rated/nominal/Nennmaße) 4 supporti per lastra/supports per slab/ vérins par plaque/Stützen pro Platte		<b>4 supporti/supports/ vérins/Stützen</b> 90x90 → 3 pcs/m <sup>2</sup>	<b>Non applicabile/ Not applicable/ Non possible/ Nicht anwendbar</b>	<b>Non applicabile/ Not applicable/ Not possible/ Nicht anwendbar</b>
<b>cm 60x60</b> (nominale/rated/nominal/Nennmaße) 4 supporti per lastra/supports per slab/ vérins par plaque/Stützen pro Platte		<b>4 supporti/supports/ vérins/Stützen</b> → 3,4 pcs/m <sup>2</sup>	<b>4 supporti/supports/ vérins/Stützen</b> → 3,4 pcs/m <sup>2</sup>	<b>4 supporti/supports/ vérins/Stützen</b> → 3,4 pcs/m <sup>2</sup>  + Doppia rete plus o foglio di acciaio galvanizzato/Fiber-Mesh <i>Plus</i> or galvanized steel sheet/Filet plus ou feuille en acier galvanisé/ Verzinkte Stahlfolie Oder Plus-Netz

Per i mercati USA, Canada e Oceania/For USA, Canada and Oceania markets/Pour les marchés USA, Canada et Océanie/Für die Märkte in USA, Kanada und Ozeanien

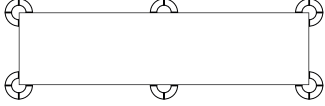
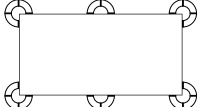
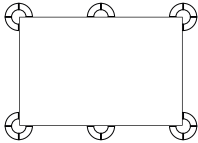
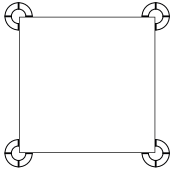
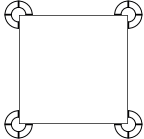
Size		Up to 2 cm (3/4")	Above 2 cm (3/4")
<b>cm 40x120/16"x48" (rated)</b> 6 supports per slab		<b>6 supports</b> → 7,0 pcs/m <sup>2</sup> → 0,65 pcs/sq ft	Please contact Ceramiche Refin SpA
<b>cm 45x90/18"x36" (rated)</b> 6 supports per slab		<b>6 supports</b> → 6,0 pcs/m <sup>2</sup> → 0,56 pcs/sq ft	Please contact Ceramiche Refin SpA
<b>cm 60x90/24"x36" (rated)</b> 6 supports per slab		<b>6 supports</b> → 6,0 pcs/m <sup>2</sup> → 0,56 pcs/sq ft	Please contact Ceramiche Refin SpA
<b>cm 90x90/36"x36" (rated)</b> 4 supports per slab		<b>4 supports</b> 90x90/36"x36" → 3 pcs/m <sup>2</sup> → 0,28 pcs/sq ft	Please contact Ceramiche Refin SpA
<b>cm 60x60/24"x24" (rated)</b> 4 supports per slab		<b>4 supports</b> → 3,4 pcs/m <sup>2</sup> → 0,32 pcs/sq ft	Please contact Ceramiche Refin SpA



# Trim tiles

Battiscopa  
**A x B**  
**7x90 / 2<sup>7</sup>/<sub>8</sub>"x36"**  
**7x75 / 2<sup>7</sup>/<sub>8</sub>"x30"**  
**10x60 / 4"x24"**  
**7x60 / 2<sup>7</sup>/<sub>8</sub>"x24"**

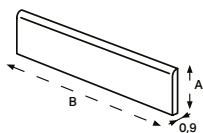

Battiscopa  
**A x B**  
**8,5x45 / 3<sup>1</sup>/<sub>2</sub>"x18"**

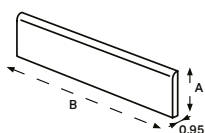

Elemento L  
**A x B**  
**16,5x30 / 6<sup>3</sup>/<sub>4</sub>"x12"**

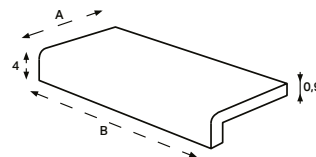

Scalino  
**A x B**  
**33x150 / 13"x60"**

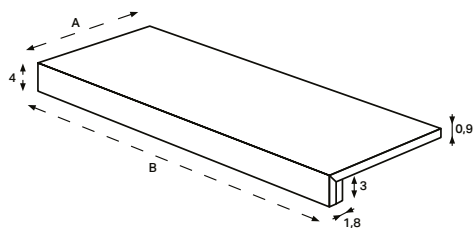

Angolo Scalino DX e SX  
**A x B**  
**33x150 / 13"x60"**

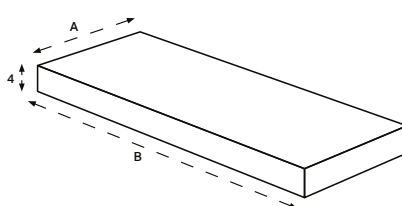

Scalino  
**A x B**  
**30x60 / 12"x24"**

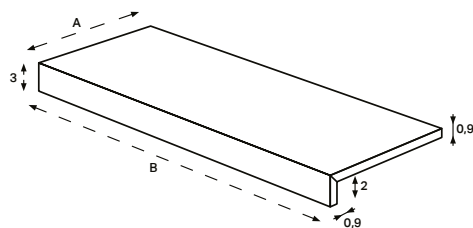

Angolo Scalino DX e SX  
**A x B**  
**30x30 / 12"x12"**

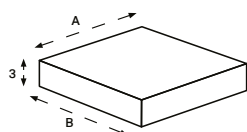

Gradino industriale  
**A x B**  
**30x60 / 12"x24"**  
**30x30 / 12"x12"**

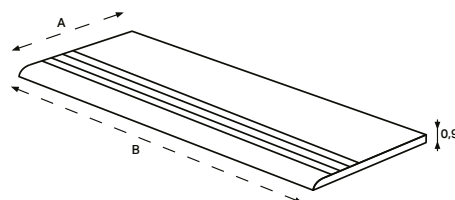

Gradino industriale  
**A x B**  
**45x45 / 18"x18"**

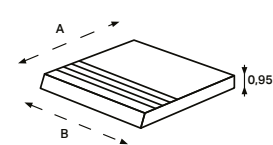

# Trim tiles OUT2.0

# 344/345

Bordo  
A x B  
30x120 / 12"x48"  
30x90 / 12"x36"  
30x60 / 12"x24"  
15x60 / 6"x24"

Lato bisellato  
Bevelled side  
Côté biseauté  
FacettenKante

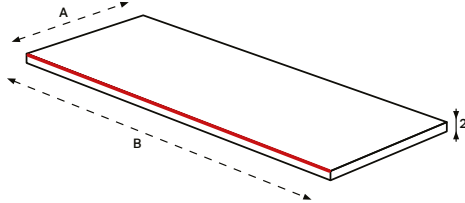

Bordo Angolo DX/SX  
A x B  
30x120 / 12"x48"  
30x90 / 12"x36"  
30x60 / 12"x24"  
15x60 / 6"x24"

Lato bisellato  
Bevelled side  
Côté biseauté  
FacettenKante

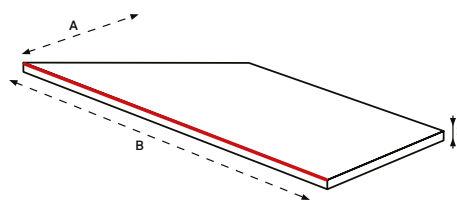

Bordo Angolo  
A x B  
30x30 / 12"x12"  
15x15 / 6"x6"

Lato bisellato  
Bevelled side  
Côté biseauté  
FacettenKante

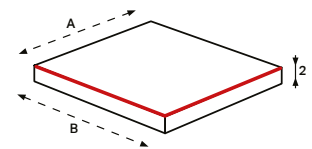

Gradino  
A x B  
33x120 / 13"x48"  
33x90 / 13"x36"  
30x60 / 12"x24"  
15x60 / 6"x24"

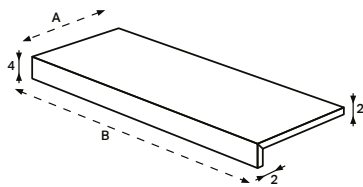

Gradino Angolo DX/SX  
A x B  
33x120 / 13"x48"  
33x90 / 13"x36"  
30x60 / 12"x24"  
15x60 / 6"x24"

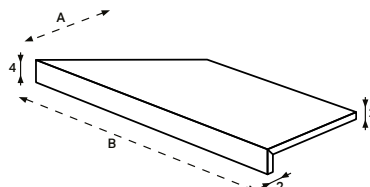

Gradino Angolo  
A x B  
33x33 / 13"x13"  
30x30 / 12"x12"  
15x15 / 6"x6"

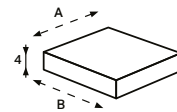

Elemento L  
A x B  
15x90 / 6"x36"  
15x60 / 6"x24"

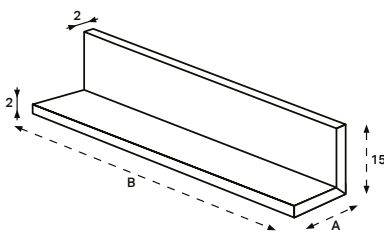

Elemento U  
A x B  
15x90 / 6"x36"  
15x60 / 6"x24"

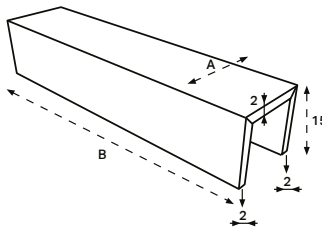

Griglia  
A x B  
20x90 / 8"x36"  
15x90 / 6"x36"  
20x60 / 8"x24"  
15x60 / 6"x24"

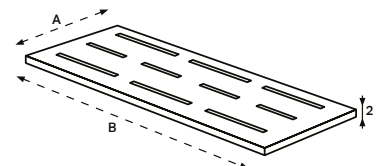

Angolo L DX/SX  
A x B  
15x90 / 6"x36"  
15x60 / 6"x24"

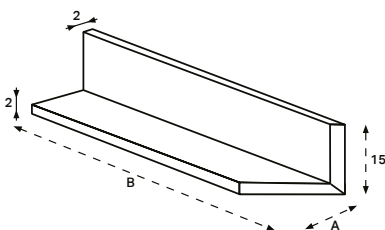

Angolo U DX/SX  
A x B  
15x90 / 6"x36"  
15x60 / 6"x24"

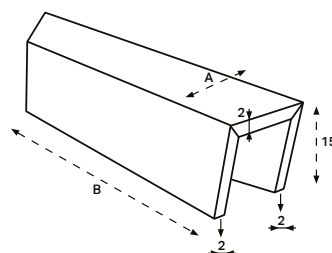

Griglia Angolo  
A x B  
20x20 / 8"x8"  
15x15 / 6"x6"

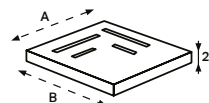



# Surfaces

# 346/347

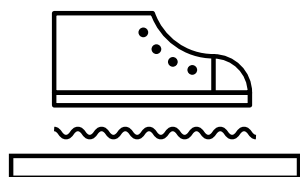

Grazie al know-how sviluppato negli anni, la divisione ricerca e sviluppo di Ceramiche Refin ha messo a punto diverse tipologie di finitura superficiale per il grés, che restituiscono risultati visivi diversi e caratteristiche specifiche di resistenza allo scivolamento. Ogni superficie può essere classificata in base ai principali parametri di riferimento delle più importanti normative internazionali in materia.

Thanks to know-how developed over the years, the Ceramiche Refin research and development division has created various types of surface finish for stoneware, each of which offers different visual results and specific characteristics of slip-resistance. Each surface can be classified according to key parameters of reference set by the most important international standards on the subject.

Grâce à un savoir-faire développé au fil des années, la division Recherche et Développement de Ceramiche Refin a mis au point plusieurs types de finition des surfaces pour les grés, qui proposent des résultats visuels différents et des caractéristiques anti-dérapantes spécifiques. Chaque surface peut être classée en fonction des principaux paramètres de référence des réglementations internationales les plus importantes en la matière.

Dank ihres im Laufe der Jahre erworbenen Know-hows hat die Abteilung Forschung und Entwicklung von Ceramiche Refin für das produzierte Feinsteinzeug verschiedene Oberflächen Ausführungen von jeweils unterschiedlicher Optik und Rutschfestigkeit entwickelt. Jede Oberfläche ist nach den Hauptparametern der wichtigsten internationalen Bezugsregelwerke klassifizierbar.

Dankzij de knowhow die het bedrijf in de loop der jaren heeft opgedaan, heeft de Research and Development-afdeling van Ceramiche Refin verschillende soorten oppervlakteafwerkingen uitgewerkt voor gres, met diverse visuele resultaten en specifieke slipbestendige eigenschappen. Elk oppervlak kan worden geclassificeerd op basis van de voornaamste referentieparameters van de belangrijkste internationale normen op dit gebied.

Gracias a los conocimientos atesorados a lo largo de los años, el departamento de Investigación y Desarrollo de Ceramiche Refin ha elaborado distintos tipos de acabado superficial para el gres, que ofrecen diferentes resultados visuales y características específicas de resistencia al deslizamiento. Cada superficie se puede clasificar según los principales parámetros de referencia de las normas internacionales más importantes.

Test method	Refin surface: Lappato/Lucido	Refin surface: Soft	Refin surface: Matt	Refin surface: C1	Refin surface: C2	Refin surface: C3
DIN 51130	-	-	R9 / R10	R10	R11	R12
DIN 51097	-	-	A / A + B	A + B	A + B + C	A + B + C
BOT3000	-	> 0,42 Wet	> 0,42 Wet	> 0,42 Wet	> 0,42 Wet	> 0,42 Wet
BCRA	-	Asciutto > 0,40 / Bagnato > 0,40	Asciutto > 0,40 / Bagnato > 0,40	Asciutto > 0,40 / Bagnato > 0,40	Asciutto > 0,40 / Bagnato > 0,40	Asciutto > 0,40 / Bagnato > 0,40
PENDULUM BS 7976-2:2002	-	-	See each collection	Low slip potential	Low slip potential	Low slip potential

Lavabo da appoggio/Countertop  
washbasin 60×42,8  
Urbex Style Graphite

Top lavabo/ Washbasin countertop 120×50  
Urbex Style Graphite

Pavimento/Floor  
Urbex Style Graphite 120×120/48"×48"

Parete/Wall  
Foil Verdigris 60×120/24"×48"



# Balneo project

# 348/349

Balneo project è il sistema di elementi per il bagno personalizzabili creato da Refin. Grazie a Balneo project è possibile dare vita ad ambienti dalla forte continuità estetica, con soluzioni coordinate tra elementi d'arredo, pareti e pavimentazione. Gli elementi sono costituiti da una struttura interna che assicura solidità e impermeabilità, fissata al gres porcellanato con collanti specifici. Gli elementi di Balneo project mantengono le caratteristiche tecniche del gres porcellanato Refin: impermeabilità, resistenza agli agenti chimici e alle macchie, resistenza all'abrasione e facilità di pulizia.

Balneo project is the system of elements for personalised bathrooms created by Refin. Thanks to Balneo project one can create spaces with strong aesthetic continuity, with solutions that are coordinated in terms of the furnishing elements, walls and floors. The elements comprise an internal structure, which ensures solidity and waterproofing, affixed to porcelain tile with specific adhesives. The Balneo project elements retain the technical characteristics of Refin porcelain tile, in that they are waterproof, resistant to chemical agents and marks, resistant to abrasion and easy to clean.

Balneo project est le système d'éléments personnalisés pour la salle de bains créé par Refin. Grâce à Balneo project, il est possible de créer des espaces à forte continuité esthétique, avec des solutions coordonnées entre les éléments de décoration, les parois et le revêtement de sol. Les éléments sont composés d'une surface interne qui garantit solidité et imperméabilité, fixée au grès cérame grâce à des colles spécifiques. Les éléments Balneo project conservent les caractéristiques techniques du grès cérame Refin: imperméabilité, résistance aux agents chimiques et aux taches, résistance à l'abrasion et facilité de nettoyage.

Mit Balneo project bezeichnet Refin das von ihr entwickelte System von anpassbaren Badezimmer-elementen. Balneo project verleiht den Umgebungen eine starke optische Kontinuität, mit aufeinander abgestimmten Einrichtungselementen, Wänden und Bodenbelägen. Die Elemente weisen eine innere Struktur auf, die Festigkeit und Dichtheit gewährleistet und mit speziellen Klebstoffen am Feinsteinzeug befestigt wird. Alle Elemente des Balneo project weisen die gleichen technischen Eigenschaften wie Feinsteinzeug auf: Wasserundurchlässigkeit, Chemikalien- und Fleckenbeständigkeit, Abriebfestigkeit und leichte Reinigung.

Balneo project is het systeem van aanpasbare badkamer-elementen dat door Refin is gecreëerd. Dankzij Balneo project is het mogelijk om omgevingen te creëren met een sterke esthetische continuïteit, met gecoördineerde oplossingen tussen inrichtingselementen, wanden en vloeren. De elementen bestaan uit een interne structuur die voor stevigheid en ondoordringbaarheid zorgt en die door middel van specifieke lijmen op het porseleingres bevestigd is. De Balneo project-elementen behouden de technische kenmerken van het porseleingres van Refin: ondoordringbaarheid, bestendigheid tegen chemische middelen en vlekken, bestendigheid tegen slijtage en gemakkelijk te reinigen.

Balneo project es el sistema de elementos personalizables para el baño creado por Refin. Gracias a Balneo project es posible crear espacios de gran continuidad estética, con soluciones a juego entre elementos de decoración, revestimientos y pavimentos. Los elementos están provistos de una estructura interna, que garantiza solidez e impermeabilidad, que se sujeta al gres porcelánico mediante adhesivos especiales. Los elementos Balneo project poseen las características técnicas del gres porcelánico Refin: impermeabilidad, resistencia a los agentes químicos y a las manchas, resistencia a la abrasión y facilidad de limpieza.

Gres porcellanato  
Porcelain stoneware  
Grès cérame fin vitrifié  
Feinsteinzeug  
Porseleingres  
Gres porcelánico

# Balneo project

## Lavabo da appoggio/Countertop washbasin

Abbinabile al top per lavabo/Can be combined with the washbasin countertop

### 60×42,8 cm scarico nascosto/concealed drainage

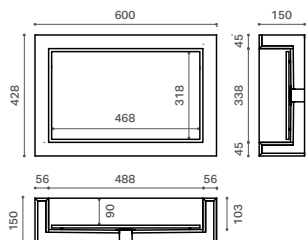

### 60×42,8 cm scarico a vista/visible drainage

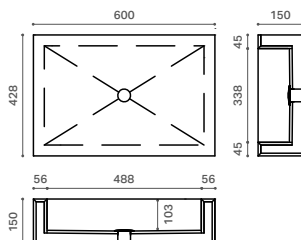

## Lavabo sospeso/Wall-mounted washbasin

### 90×50 cm scarico a vista/visible drainage

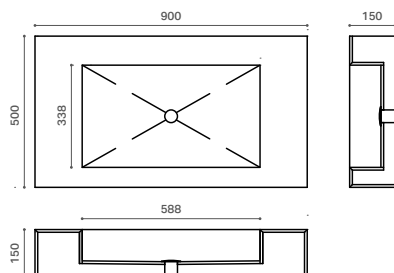

### 90×50 cm scarico nascosto/concealed drainage

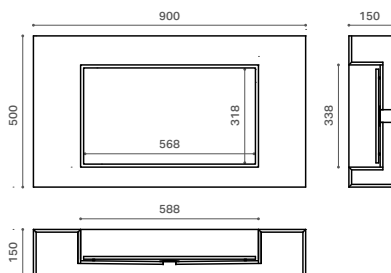

### 120×50 cm scarico a vista/visible drainage

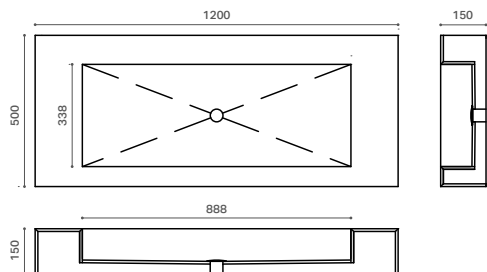

### 120×50 cm scarico nascosto/concealed drainage

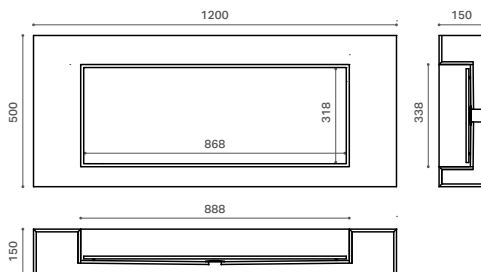

## Top lavabo/Washbasin countertop

Abbinabile al lavabo da appoggio/Can be combined with the countertop washbasin

80x50 cm

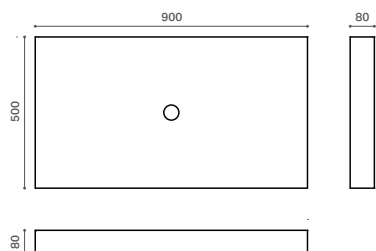

120x50 cm

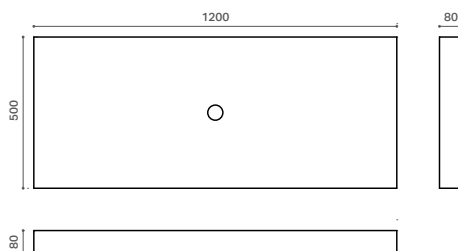

## Piatta doccia/Shower tray

80x80 cm

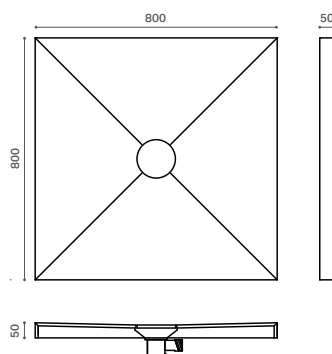

90x90 cm

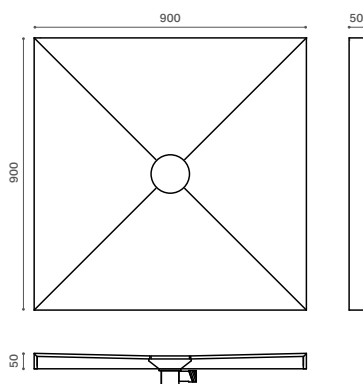

120x80 cm

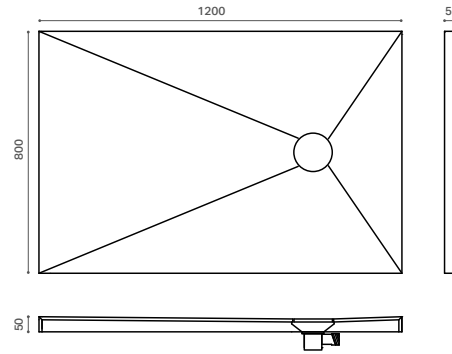

## Componenti/Components/Composants/Komponenten/Componenten/Componentes

Gli articoli Balneo project sono ricavati dal taglio di lastre in gres porcellanato assemblate con collanti e stucchi epossidici su una struttura interna realizzata in polistirene ad alta densità. Possono essere realizzati su richiesta per tutte le collezioni Refin utilizzando lastre di formato 120x120 o 75x150cm (i piatti doccia solo dal formato 120x120). I tecnici di Ceramiche Refin sono a disposizione per la scelta del materiale più idoneo per la realizzazione dei piatti doccia e degli altri elementi.

Balneo project articles are created from cut porcelain tile slabs assembled using epoxy adhesives and sealants on an internal structure in high-density polystyrene. They can be tailor-made for all Refin collections, using 120x120 or 75x150cm size slabs (shower trays only from size 120x120). Ceramiche Refin technicians are on hand to assist with selection of the most suitable material for the creation of shower bases and other elements.

Les articles Balneo project proviennent de la découpe de dalles en grès cérame assemblées avec des colles et des mortiers époxy sur une structure intérieure réalisée en polystyrène haute densité. Ils peuvent être réalisés sur demande pour toutes les collections Refin utilisant des dalles de format 120x120 ou 75x150 cm (uniquement à partir du format 120x120 pour les receveurs de douche). Les techniciens de Ceramiche Refin sont à votre disposition pour le choix du matériau le plus approprié à la réalisation des receveurs de douche et autres éléments.

Die Produkte der Linie Balneo project werden auf Wunsch mit allen Refin-Kollektionen aus Platten im Format 120x120 o 75x150 cm (Duschwannen nur ab Format 120x120) angefertigt werden. Das Fachpersonal von Ceramiche Refin unterstützt Sie gern bei der Wahl des geeignetsten Materials für die Duschwannen und weiteren Elemente.

De artikelen Balneo project zijn gemaakt van gesneden platen van porseleingres, met epoxy bindmiddelen en hars geassembleerd op een interne structuur van high-density polystyrene. Ze kunnen op aanvraag worden gerealiseerd voor alle Refin-collecties, uit platen van het formaat 120x120 of 75x150 cm (doucheplaten alleen van het formaat 120x120). De technici van Ceramiche Refin staan gereed om u te helpen bij het kiezen van het meest geschikte materiaal om doucheplaten en andere elementen te realiseren.

Los artículos Balneo project se obtienen del corte de placas de gres porcelánico ensambladas con adhesivos y materiales de rejuntado epoxi sobre una estructura interna de poliestireno de alta densidad. Se pueden realizar bajo pedido para todas las colecciones Refin utilizando placas de formato 120x120 o 75x150 cm (los platos de ducha sólo con placas de formato 120x120). Los técnicos de Ceramiche Refin están a su disposición para la elección del material más adecuado para la realización de platos de ducha y otros elementos.





# Certifications 352/353

#### **LE NORME CEN (Comité Européen de Normalisation)**

Le norme CEN EN 14411, pur non avendo valore di legge, costituiscono un riferimento in qualsiasi controversia e contestazione. Tali norme sono accettate dai seguenti paesi aderenti al CEN: Austria, Belgio, Danimarca, Finlandia, Francia, Germania, Gran Bretagna, Grecia, Irlanda, Islanda, Italia, Lussemburgo, Malta, Norvegia, Paesi Bassi, Portogallo, Repubblica Ceca, Spagna, Svezia, Svizzera.

**A livello internazionale, Refin fa riferimento alle normative ISO 13006, riconosciute nella maggior parte dei paesi del mondo.**

Ceramiche Refin SpA garantisce i propri prodotti secondo le norme UNI EN 14411 – ISO 13006. Norme nazionali o locali diverse da quanto sopra devono essere autorizzate da Ceramiche REFIN SpA.

#### **CEN STANDARDS (Comité Européen de Normalisation)**

Although not legally binding, CEN EN 14411 standards are used as a reference in the event of claims and litigation. These standards are accepted by the following CEN member countries: Austria, Belgium, Czech Republic, Denmark, Finland, France, Germany, Greece, Iceland, Ireland, Italy, Luxembourg, Malta, Norway, Netherlands, Portugal, Spain, Sweden, Switzerland, United Kingdom.

**Refin complies with ISO 13006 standards, which are accepted in most countries across the world**

Ceramiche Refin Spa guarantees its products as complying with UNI EN 14411 – ISO 13006 standards. Any other national or local standards other than the ones mentioned above must be authorized by Ceramiche REFIN Spa.

#### **LES NORMES CEN (Comité Européen de Normalisation)**

Les normes CEN EN 14411, bien qu'elles n'aient pas valeur de loi, servent de référence en cas de litige et de contestation. Ces normes sont acceptées par les pays suivants, membres du CEN: Allemagne, Autriche, Belgique, Danemark, Espagne, Finlande, France, Grande Bretagne, Grèce, Irlande, Islande, Italie, Luxembourg, Malte, Norvège, Pays Bas, Portugal, République Tchèque, Suède, Suisse.

**A l'échelon international, Refin est conforme aux normes ISO 13006, reconnues dans la plupart des pays du monde.**

Ceramiche Refin Spa garantit ses produits selon les normes UNI EN 14411 - ISO 13006. Toutes normes nationales ou locales qui diffèrent de la susnommée doivent être autorisées par Ceramiche REFIN Spa.

#### **DIE CEN-NORMEN (CEN - Comité Européen de Normalisation)**

Obwohl sie gesetzlich nicht bindend sind, stellen die Normen CEN EN 14411 bei allen Kontrollen und Beanstandungen eine wichtige Richtschnur dar. Die Normen werden in folgenden CEN-Mitgliedstaaten anerkannt: Belgien, Dänemark, Deutschland, Finnland, Frankreich, Griechenland, Großbritannien, Irland, Island, Italien, Luxemburg, Malta, Niederlande, Norwegen, Österreich, Portugal, Schweden, Schweiz, Spanien, Tschechien.

**Auf internationaler Ebene nimmt Refin auf die in den meisten Ländern der Welt anerkannten Richtlinien ISO 13006 Bezug.**

Ceramiche Refin Spa garantiert ihre Produkte nach den Normen UNI EN 14411 - ISO 13006. Etwaige nationale oder örtliche Richtlinien, die von den oben angeführten Normen abweichen, sind mit Ceramiche REFIN Spa abzustimmen.

#### **DE CEN-NORME (Comité Européen de Normalisation)**

Hoewel de CEN-normen geen rechtsgeldige waarde hebben, gelden zij als referentie voor alle twisten en geschillen. Deze normen worden door de volgende CEN-lidstaten geaccepteerd: Oostenrijk, België, Denemarken, Finland, Frankrijk, Duitsland, Groot-Brittannië, Griekenland, Ierland, IJsland, Italië, Luxemburg, Malta, Noorwegen, Nederland, Portugal, Tsjechische Republiek, Spanje, Zweden, Zwitserland.

**Op internationaal niveau verwijst Refin naar de ISO 13006-normen, die in de meeste landen over de hele wereld worden erkend.**

Ceramiche Refin SpA garandeert dat haar producten voldoen aan de normen NEN EN 14411 - ISO 13006. Andere nationale of lokale voorschriften dan de hierboven genoemde moeten door Ceramiche REFIN SpA worden goedgekeurd.

#### **LAS NORMAS CEN «Comité Europeo de Normalización» (Comité Européen de Normalisation)**

Las normas CEN EN 14411, si bien no disponen de la categoría de ley, constituyen una referencia en caso de impugnación o litigio. Dichas normas han sido aceptadas en los siguientes países que han adherido al CEN: Austria, Bélgica, Dinamarca, Finlandia, Francia, Alemania, Gran Bretaña, Grecia, Irlanda, Islandia, Italia, Luxemburgo, Malta, Noruega, Países Bajos, Portugal, República Checa, España, Suecia, Suiza.

**A nivel internacional, Refin se atiene a las normas ISO 13006, reconocidas en la mayoría de los países del mundo.**

Ceramiche Refin SpA garantiza sus productos conformes a las normas UNI EN 14411 – ISO 13006. Las normas nacionales o domésticas que sean diferentes a las anteriormente citadas, tendrán que ser autorizadas por Ceramiche REFIN SpA.

DNV·GL

# MANAGEMENT SYSTEM CERTIFICATE

Certificato no./Certificate No.:  
102138-2011-AQ-ITA-ACCREDIA

Data prima emissione/Initial date:  
24 agosto 2011

Validità:/Valid:  
28 novembre 2018 - 28 novembre 2021

Si certifica che il sistema di gestione di/This is to certify that the management system of

## CERAMICHE REFIN S.p.A.

Via I Maggio, 22 - 42013 Casalgrande (RE) - Italy  
(Riferimento al Certificato No./Reference to Certificate No. 196612-2015-AQ-ITA-ACCREDIA)

È conforme ai requisiti della norma per il Sistema di Gestione Qualità/  
has been found to conform to the Quality Management System standard:

### ISO 9001:2015

Questa certificazione è valida  
per il seguente campo applicativo:

**Progettazione e produzione di piastrelle  
ceramiche in gres porcellanato**

(EA: 15)

This certificate is valid  
for the following scope:

**Design and manufacture  
of porcelain stone**

(EA: 15)

Luogo e Data/Place and date:  
**Vimercate (MB), 23 novembre 2018**



ISOQ N° 003 A  
SGA N° 003 D  
SGE N° 007 M  
SCR N° 004 F  
EMAS N° 009 P  
FRS N° 003 B  
FRS N° 004 C  
SSI N° 002 G  
Membro di IMLA EA per gli schemi di accreditamento  
SGQ, SGA, PRO, PMS, ISO, GRI, LAR e LAF di IMLA IAF  
per gli schemi di accreditamento SGQ, SGA, SSI, PSM  
e PRO e di IMLA ILAC per gli schemi di accreditamento  
LAR, MRO, LAF e DSP

Per l'Organismo di Certificazione/  
For the Certification Body  
**DNV GL - Business Assurance**  
**Via Energy Park, 14**  
**20871 Vimercate (MB) - Italy**

**Zeno Beltrami**  
Management Representative

Ceramiche Refin SpA è  
certificata secondo la  
norma **ISO 9001**,  
riconoscimento  
internazionale riferito al  
**Sistema di Gestione  
della Qualità** aziendale.

Ceramiche Refin SpA is  
certified to the **ISO  
9001** standard, an  
international standard  
that applies to  
corporate **quality  
management systems**.

Ceramiche Refin SpA est  
certifiée suivant la  
norme **ISO 9001**, une  
reconnaissance  
internationale relative au  
**Système de Gestion de  
la Qualité** de l'entreprise.

I certificati aggiornati sono disponibili sul sito [www.refin.it](http://www.refin.it)  
Updated certificates are available on [www.refin.it](http://www.refin.it)  
Les certificats mis à jour sont disponibles sur le site [www.refin.it](http://www.refin.it)  
Die aktualisierten Zertifikate sind auf der Internetseite [www.refin.it](http://www.refin.it) verfügbar  
De certificaten zijn up-to-date te vinden op onze website [www.refin.it](http://www.refin.it)  
Los certificados actualizados están disponibles en el sitio web [www.refin.it](http://www.refin.it)

Consapevole dell'inestimabile valore della salute e della sicurezza sul lavoro, Refin ha predisposto le più aggiornate misure di prevenzione e protezione ed ha implementato un **Sistema di Gestione per la Salute e Sicurezza sul Lavoro** secondo lo standard volontario **BS OHSAS 18001** certificato dall'ente accreditato **DNV-GL**. Il testo completo della politica per la salute e sicurezza sul lavoro è disponibile sul sito web aziendale.

Aware of the priceless value of workplace health and safety, Refin takes cutting-edge preventive and protective measures and implements a **workplace health and safety management system**, based on the **BS OHSAS 18001** voluntary standard as certified by **DNV-GL**. The full text of the workplace health and safety policy can be consulted on the company's website.

Compte tenu de la valeur inestimable de la santé et de la sécurité sur le lieu de travail, Refin a mis en place les mesures de prévention et de protection les plus récentes et les plus à jour et elle a implémenté un **Système de Gestion pour la Santé et la Sécurité sur le Lieu de Travail** conforme au standard volontaire **BS OHSAS 18001** certifié par l'organisme **DNV-GL**. Le texte complet de la politique pour la santé et la sécurité sur le lieu de travail est disponible sur le site web de l'entreprise.

DNV-GL

# MANAGEMENT SYSTEM CERTIFICATE

Certificato No./Certificate No.: 238771CC5-2017-AHSO-ITA-ACCREDIA      Data prima emissione/Initial date: 20 febbraio 2018      Validità/Valid: 20 febbraio 2018 - 20 febbraio 2021

Si certifica che il sistema di gestione di/This is to certify that the management system of

## CERAMICHE REFIN S.p.A

Via I° Maggio, 22 42013 Salvaterra Casalgrande (RE) - Italy

(Riferimento al Certificato No./ Reference to Certificate No. 238771-2017-AHSO-ITA-ACCREDIA)

È conforme ai requisiti della norma per il Sistema di Gestione della Salute e Sicurezza sul Lavoro/  
has been found to conform to the Occupational Health and Safety Management System standard

### OHSAS 18001:2007

Questa certificazione è valida per il seguente campo applicativo:

**Progettazione e produzione di piastrelle e lastre ceramiche in gres porcellanato attraverso le fasi di macinazione, atomizzazione, pressatura, decorazione, cottura e squadratura**

(Settore EA: 15)

This certificate is valid for the following scope:

**Design and manufacture of porcelain stoneware ceramic tiles and slabs through the phases of milling, spray drying, pressing, decoration, firing and squaring**

(EA Sector: 15)

Luogo e Data/Place and date:  
**Vimercate (MB), 20 febbraio 2018**



SGQ N° 003 A      ENAS N° 009 F  
SGA N° 003 D      PRD N° 003 B  
SGE N° 007 M      PPS N° 004 C  
SCS N° 004 F      SIE N° 002 G

Membro di IMA EA per gli schemi di accreditamento  
SGQ, SGA, PRD, PPS, ISR, GHS, LAB e LAT, di IMA IAF  
per gli schemi di accreditamento SGQ, SGA, SSI, FSM  
e IMA ILAC per gli schemi di accreditamento  
LAB, MED, LAT e ISF

Per l'Organismo di Certificazione/  
For the Certification Body

**Zeno Beltrami**  
Management Representative

La validità del presente Certificato è subordinata al rispetto delle condizioni contenute nel Contratto di Certificazione/  
Lack of fulfilment of conditions as set out in the Certification Agreement may render this Certificate invalid.  
DNV GL Business Assurance Italia S.r.l. Via Energy Park, 14, 20871 Vimercate (MB), Italy. Tel: 039 68 99 905. [www.dnvgl.it/assurance](http://www.dnvgl.it/assurance)

DNV·GL

# VERIFICATION STATEMENT

Attestato No./Statement No.:  
266136-2018-OTH-ITA-DNV

Data prima emissione/Initial date:  
18 giugno 2018

Validità/Valid:  
18 giugno 2018 - 18 giugno 2021

Si attesta che l'autodichiarazione ambientale "GRÈS PORCELAIN STONEWARE ISO 14021 DECLARATION" Rev.00 del 14 giugno 2018 effettuata da/  
This is to certify that Environmental Self declaration "GRÈS PORCELAIN STONEWARE ISO 14021 DECLARATION" Rev.00 on 14 June 2018 issued by

## Ceramiche Refin S.p.A.

Via I Maggio 22 - 42013 Salvaterra Casalgrande (RE) - Italy

per la produzione di "Piastrelle e lastre in gres porcellanato (standard e spesse)" è stata verificata in accordo ai paragrafi applicabili dell'ISO 14021:2016 "Etichette e dichiarazioni ambientali - Asserzioni ambientali auto-dichiarate (Etichettatura ambientale Tipo II)" per i seguenti aspetti ambientali: consumo e uso d'acqua, emissioni in atmosfera (particolato e fluoruri), emissioni nell'acqua e recupero dei rifiuti, come dettagliato nel Rapporto DNV GL Rev. 1 del 2018-06-15/  
for the production of "Tiles and slabs in Gres Porcelain stoneware (standard and thicker)" has been verified according to applicable paragraphs of ISO 14021:2016 "Environmental labels and declarations - Self-declared environmental claims (Type II environmental labelling)" for the following environmental aspects: consumption and use of water, air emissions (particulate and fluoride), water emissions and waste recovery, as detailed in the DNV GL report Rev. 1 on 2018-06-15.

L'attestazione è rilasciata in base alla procedura di valutazione DNV GL Business Assurance Italia S.r.l. relativamente ai dati dichiarati e alla metodologia adottata/  
The statement is issued according to DNV GL Business Assurance Italia S.r.l. assessment procedure about declared data and adopted methodology.

Luogo e Data/Place and date:  
Vimercate (MB), 18 giugno 2018



Per l'Organismo di Certificazione/  
For the Certification Body

**Zeno Beltrami**  
Management Representative

La validità del presente Certificato è subordinata al rispetto delle condizioni contenute nel Contratto di Certificazione/  
Lack of fulfilment of conditions as set out in the Certification Agreement may render this Certificate invalid.  
DNV GL Business Assurance Italia S.r.l. Via Energy Park, 14, 20871 Vimercate (MB), Italy. Tel: 039 68 99 905. [www.dnvgl.it/assurance](http://www.dnvgl.it/assurance)

La norma internazionale ISO 14021:2016 detta le regole per le auto-dichiarazioni ambientali da parte dei produttori e ne descrive una metodologia generale di valutazione e verifica.

The International Standard ISO 14021:2016 specifies requirements for self-declared environmental claims made by manufacturers and describes a general evaluation and verification methodology.

La Norme internationale ISO 14021:2016 établit les règles relatives aux autodéclarations environnementales établies par des fabricants et en décrit également une méthodologie générale d'évaluation et de contrôle.

I certificati aggiornati sono disponibili sul sito [www.refin.it](http://www.refin.it)  
Updated certificates are available on [www.refin.it](http://www.refin.it)  
Les certificats mis à jour sont disponibles sur le site [www.refin.it](http://www.refin.it)  
Die aktualisierten Zertifikate sind auf der Internetseite [www.refin.it](http://www.refin.it) verfügbar  
De certificaten zijn up-to-date te vinden op onze website [www.refin.it](http://www.refin.it)  
Los certificados actualizados están disponibles en el sitio web [www.refin.it](http://www.refin.it)

Refin ha conseguito anche l' **EPD – Environmental Product Declaration**, dichiarazione ambientale di prodotto su base volontaria che attesta l'impatto ambientale del ciclo di vita del prodotto secondo l'approccio "dalla culla al cancello".

Refin achieved also the **EPD**, the voluntary **Environmental Product Declaration** which certifies the environmental impact of a product with a "from cradle to gate" approach.

Refin a reçu aussi la **EPD – Environmental Product Declaration**, déclaration environnementale faite volontairement, qui certifie l'impact environnemental de le cycle de vie du produit selon l'approche « de l'extraction à la fin de vie ».



## ENVIRONMENTAL PRODUCT DECLARATION

Product name:

**Porcelain stoneware**  
**Ceramic tiles and slabs**

Site Plant:

**Via I Maggio,22**  
**42013, Casalgrande (RE), Italia**

in compliance with ISO 14025 and EN 15804

Program Operator	EPDItaly
Publisher	EPDItaly
Declaration Number	EPD-03-REF
EPDItaly Registration Number	EPDITALY0034
ECO EPD Registration Number	00000759
Issue Date	01/09/2018
Valid to	01/09/2023



DNV GL

# Verification STATEMENT

## Product Environmental Footprint (PEF)

issued by DNV GL Business Assurance Italia S.r.l.

Statement No.:  
216502-2017-OTH-ITA-DNV

Initial Issued Date:  
30 march 2017

It is hereby certified that the Product Environmental Footprint (PEF) for:

**Grès Porcelain Stoneware, traditional thickness**  
**Grès Porcelain Stoneware, increased thickness**

made by

**Ceramiche Refin**

Via I Maggio, 22 Salvaterra - 42013 Casalgrande (RE) - Italy

Covered by the study:

"Product Environmental Footprint Report for the items: Porcelain stoneware, traditional thickness & Porcelain stoneware, increased thickness, Made by Ceramiche Refin S.p.A." ( rev.00 of 23/02/2017)

Based on the Critical Review actions carried out, the following requirements are satisfied:

- The methods used for carrying out the study are in accordance with the guidelines for the PEF (Product Environmental Footprint), as defined in European Commission Recommendation 2013/179/EU.
- The methods used for carrying out the PEF study are valid from a technical and scientific point of view.
- The data used was adequate, reasonable and corresponds to the quality data requirements.
- Interpretation of the results takes the limitations identified into account.
- The study report is clear, precise and coherent.  
(Ref. Par. 9.1 of Annexure II to European Commission recommendation 2013/179/EU).

A check was also done on the document:

"GRÈS PORCELAIN STONWARE PEF DECLARATION" Ceramiche Refin (rev. 23/02/2017), the contents of which conform to § 9.2 of ISO 14025:2010.

This statement is issued, based on the analyses done according to the audit methodology used by DNV GL Business Assurance Italia S.r.l.

Place and Date:  
**Vimercate (MB), 30 march 2017**

For the Certification Body

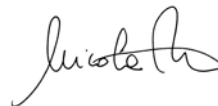

**Nicola Privato**  
Management Representative

The validity of this Statement is subject to conformity to the conditions contained in the Contract /  
Lack of fulfilment of conditions as set out in the Agreement may render this Statement invalid.  
DNV GL Business Assurance Italia S.r.l. Via Energy Park, 14, 20871 Vimercate (MB), Italy. Tel: 039 68 99 905. [www.dnvgl.it/assurance](http://www.dnvgl.it/assurance)

Introdotta dall'Unione Europea, la certificazione **PEF – Product Environmental Footprint** è relativa alla determinazione del potenziale impatto ambientale dei prodotti nel corso del loro ciclo di vita. Il certificato attesta la validità delle informazioni sulle performance ambientali dei prodotti Refin e la conformità alle metodologie PEF.

Introduced by the European Union, the **PEF – Product Environmental Footprint** certification is a measure of the environmental impact of a product during its life cycle. Such certificate is evidence of the sound environmental performance and PEF compliance of Refin products.

Introduite par l'Union Européenne, la certification **PEF – Product Environmental Footprint** concerne la détermination de l'impact potentiel que les produits peuvent avoir sur l'environnement pendant leur cycle de vie. Ce certificat prouve la validité des informations sur les performances environnementales des produits Refin, ainsi que leur conformité aux méthodes PEF.



I certificati aggiornati sono disponibili sul sito [www.refin.it](http://www.refin.it)  
Updated certificates are available on [www.refin.it](http://www.refin.it)  
Les certificats mis à jour sont disponibles sur le site [www.refin.it](http://www.refin.it)  
Die aktualisierten Zertifikate sind auf der Internetseite [www.refin.it](http://www.refin.it) verfügbar  
De certificaten zijn up-to-date te vinden op onze website [www.refin.it](http://www.refin.it)  
Los certificados actualizados están disponibles en el sitio web [www.refin.it](http://www.refin.it)

In quanto parte del sistema edificio, le piastrelle Refin contribuiscono all'ottenimento dei crediti per diverse categorie della certificazione LEED – Leadership in Energy and Environmental Design. In particolare, le collezioni Refin realizzate con materiale riciclato consentono di ottimizzare il punteggio LEED ottenibile per la categoria Materiali e Risorse. L'elenco completo dei prodotti Refin che consentono di ottenere crediti per questa ed altre categorie LEED è disponibile sul sito web aziendale.

As part of a building as a 'system', Refin tiles help get credits in several categories of the LEED – Leadership in Energy and Environmental Design certification. In particular, Refin ranges made from recycled materials optimise the LEED score in the Materials and Resources category. A full list of Refin products that can receive credits in this and other LEED categories can be consulted on the company's website.

En tant que partie du système global du bâtiment, les carreaux Refin contribuent à obtenir des crédits pour différentes catégories de la certification LEED – Leadership in Energy and Environmental Design. Tout particulièrement, les collections Refin réalisées avec du matériel recyclé permettent d'optimiser le score LEED que l'on peut obtenir pour la catégorie Matériels et Ressources. La liste complète des produits Refin qui permettent d'obtenir des crédits pour cette (et d'autres) catégorie(s) LEED est disponible sur le site web de l'entreprise.

DNV·GL

# PRODUCT CERTIFICATE

Certificato No./Certificate No.:  
13198-2018-PC-ITA-DNV

Data prima emissione/Initial date:  
17 settembre 2018

Validità/Valid:  
17 settembre 2018 - 17 settembre 2021

Il presente Certificato è costituito da 11 pagine/This Certificate consists in 11 pages

In conformità ai regolamenti di DNV GL per la Certificazione di prodotto è stato constatato che il prodotto/

In compliance with DNV GL guidelines for the Certification of product, it has been stated that the product:

## piastrelle e lastre in gres porcellanato porcelain stoneware ceramic tiles and slabs

Realizzati da o per/Manufactured by or for:

### Ceramiche Refin S.p.A.

Via I maggio, 22 – 42013 Salvaterra di Casalgrande (RE) – Italy

Sono stati valutati in conformità ai requisiti stabiliti dalle linee guida:  
Have been evaluated in conformity with requirements defined by:

### I contributi delle piastrelle di ceramica nel sistema LEED® V 4 Contribution from ceramic tiles to LEED® V 4 system

emessa da/issued by **Confindustria Ceramica**

Questa certificazione è valida  
per i prodotti definiti nelle seguenti pagine

This certificate is valid  
for the products defined in the following pages.

Place and date/ Luogo e Data:  
**Vimercate, 17 settembre 2018**

For the Certification Body  
Per l'Organismo di Certificazione/



**Zeno Beltrami**  
Management Representative

La validità del presente Certificato è subordinata al rispetto delle condizioni contenute nel Contratto di Certificazione/  
Lack of fulfilment of conditions as set out in the Certification Agreement may render this Certificate invalid.  
[DNV GL Business Assurance Italia S.r.l. Via Energy Park, 14, 20871 Vimercate \(MB\), Italy. Tel: 039 68 99 905.](http://www.dnvgl.it/businessassurance)  
[www.dnvgl.it/businessassurance](http://www.dnvgl.it/businessassurance)

I certificati aggiornati sono disponibili sul sito [www.refin.it](http://www.refin.it)  
 Updated certificates are available on [www.refin.it](http://www.refin.it)  
 Les certificats mis à jour sont disponibles sur le site [www.refin.it](http://www.refin.it)  
 Die aktualisierten Zertifikate sind auf der Internetseite [www.refin.it](http://www.refin.it) verfügbar  
 De certificaten zijn up-to-date te vinden op onze website [www.refin.it](http://www.refin.it)  
 Los certificados actualizados están disponibles en el sitio web [www.refin.it](http://www.refin.it)



**Fraunhofer**  
WKI

Fraunhofer Institute for Wood Research  
Wilhelm-Klauditz-Institut WKI

Director  
Prof. Dr. Bohumil Kasal

Bismarck-Weg 54 E  
38108 Braunschweig | Germany

Anette Liganski  
Material Analysis & Indoor Chemistry  
Phone: +49 531 2155-510 | Fax: +49 531 2155-905  
sample\_info@wki.fraunhofer.de  
www.wki.fraunhofer.de

Fraunhofer WKI | Bismarck-Weg 54 E | 38108 Braunschweig | Germany

Ceramiche Refin SpA  
Attn: Mr. Arnold Stabinger  
Via 1. Maggio, 22

I-42013 Casalgrande (RE)  
Italia - Italy

Braunschweig, 21.02.2018

**Test report No. MAIC-2018-0799**

**Customer:** Ceramiche Refin SpA, Casalgrande (RE).

**Object of the test:** Chamber emission test of stoneware tiles according to DIN EN ISO 16000 part 3, 6, 9 and 11.

**Contents:**

1. Sample description	Page 2
2. Methods	Page 3
3. Results	Page 3

This report comprises 6 pages.

The test report may be made available or duplicated only in its unabridged form. Publication in excerpt form is subject to the written consent of the Fraunhofer Institute for Wood Research – Wilhelm-Klauditz-Institut (WKI). The test results refer solely to the objects tested. The tested material was used up.

A24202

Fraunhofer-Gesellschaft zur Förderung der angewandten Forschung e.V., München  
Executive Board  
Prof. Dr.-Ing. habil. Prof. E. h. Dr.-Ing. E. h. mult. Dr. h. c. Reinhold Neugebauer, President  
Prof. Dr.-Ing. habil. Prof. Dr. rer. oec. Alfred Gossner  
Dr. rer. publ. ass. iur. Alexander Kurz  
Prof. Dr. rer. nat. Georg Rosenfeld

Cheques and transfers payable to:  
Deutsche Bank, München  
Account: 75010300000000000000  
IBAN DE96 7007 0010 0752 1933 00  
BIC (SWIFT-Code) DEUTDE33  
V.A.T. Ident. No. 01 291519805  
Tax Number 14321520392



**Fraunhofer**  
WKI

**Methods:**

**Sample preparation:** Directly after unwrapping 0.36 m<sup>2</sup> of the sample material (two tiles with the dimensions of each 30x60cm) were placed in a 1 m<sup>3</sup> glass chamber. The back side and the small faces were sealed with aluminum foil. The sample was placed on the chamber floor during the entire testing time.

**Chamber emission test:** The sample was tested in the emission test chamber without prior conditioning. After defined times, in this case after 3 and 28 days, samples of the chamber air were collected on sorbent tubes (Tenax TA) and analyzed on a thermal desorption-GC/MS system. Compounds were identified using MS-Spectra libraries, quantification was done using pure reference compound mixtures. The described method covers volatile organic compounds from C5 to C22 and has a limit of determination of approx. 1 µg/m<sup>3</sup>. Substances in the range of C6 to C16 are reported as VOC, the more volatile ones as SVOC and those eluting after C16 as SVOC.

The volatile aldehydes were trapped on DNPH-coated cartridges and analyzed after elution with acetonitrile by HPLC-UV.

The measurements were performed according to DIN EN ISO 16000 part 3, 6, 9 and 11.

**Results:**

The quantitative test results can be found on the next page.

**Le piastrelle Refin rilasciano valori sostanzialmente nulli di V.O.C.** (cessione < 1 mg/kg) e pertanto non emettono alcun contaminante nell'aria. Refin ha scelto di certificare l'emissione dei V.O.C. nonostante la nuova regolamentazione LEED v4 dichiara che le piastrelle in ceramica sono NON EMISSIVE per natura intrinseca del materiale stesso, dunque per esse non è richiesto alcun test sulle emissioni.

**Refin tiles release virtually zero V.O.C.** (release < 1 mg/kg), which means they release no contaminants into the air. Refin chose to provide a VOC certification, even though the new LEED v4 rule states that ceramic tiles are intrinsically NON-EMITTING, so they do not need to be tested for emissions.

**Les carreaux Refin dégagent des valeurs pratiquement nulles de V.O.C.** (cession < 1 mg/kg) et par conséquent ils ne dégagent aucun contaminant dans l'air. Refin a choisi de certifier l'émission des V.O.C. quoique la nouvelle réglementation LEED v4 affirme que les carreaux en céramique sont SANS EMISSIONS par la nature intrinsèque de leur matériel, et qu'il ne faut donc pas effectuer, pour ceux-ci aucun test des émissions.



**Fraunhofer**  
WKI

**Results of the chamber emission test of sample P66678 (LY35, Plant Ash, rektifiziert, 30x60cm)**

CAS-No.	Substance	Concentration in µg/m <sup>3</sup> after		Info
		3d	28d	
	Sum VVOC (≤ C6):	< 1	< 1	
	Sum VOC (C6-C16):	< 1	< 1	
	Sum SVOC (> C16):	< 1	< 1	

(The fragments/substances shown in subscript were used for the quantification)  
 Additional information: **a** acute toxic substance cat. 1+2+3 (acc. UN-GHS/CLP); **b** German LCI list; **c** safe sampling volume too low, underestimation likely; **d** odor relevant; **e** compound boiling point exceeds thermal limit of the TDS unit – underestimation likely; **f** terpene, possibly wood-related; **g** chronic toxic substance CMR cat. 1A+1B (acc. UN-GHS/CLP); **h** aromatic solvent; **i** IS-MAT-0054; **j** chlorinated solvent; **k** IS-MAT-0054; **l** specific target organ toxic substance STOT RE1+SE1 (acc. UN-GHS/CLP); **m** listed in Proposition 65; **<C6** VVOC compound; **>C16** SVOC compound.

**Lower aldehyde results of sample P66678 (LY35, Plant Ash, rektifiziert, 30x60cm)**

CAS-No.	Substance	Concentration in µg/m <sup>3</sup> after		Limit of Determination [µg/m <sup>3</sup> ]
		3d	28d	
50-00-0	Formaldehyde	< 2	< 2	2
75-07-0	Acetaldehyde	< 3	< 3	3
123-38-6	Propanal	< 3	< 3	3
123-72-8	Butanal	< 4	< 4	4
67-68-1	Acetone	< 2	< 2	2

**Parameters of the emission chamber test:**  
 Chamber type: 1m<sup>3</sup>-stainless steel chamber 16  
 Climatic conditions: 23 °C, 50 % r.h.  
 Air exchange: 0.45 h<sup>-1</sup>  
 Loading factor: 0.36 m<sup>2</sup>/m<sup>3</sup>  
 Area specific air exchange rate q: 1.25 m<sup>3</sup>/(m<sup>2</sup>·h) (scenario: floor)  
 Test started: 18.12.2017 09:12:53  
 Sampling: Tenax TA, DNPH  
 Analysis: Thermal desorption GC/MS, HPLC/UV





**Fraunhofer**  
WKI

**Chromatogram of the 3-day-measurement**

Abundance

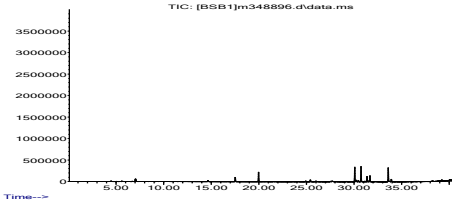

Time-->

**Chromatogram of the 28-day-measurement**

Abundance

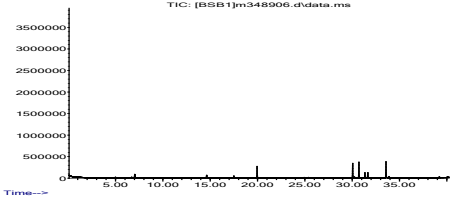

Time-->

La **FDES – Fiche de Déclaration Environnementale et Sanitaire** - è una dichiarazione ambientale per i materiali da costruzione specifica per il mercato francese. Come la EPD, prende in esame l'intero ciclo di vita dei prodotti attestandone l'eco-sostenibilità e l'idoneità per la costruzione di edifici "green".

**FDES – Fiche de Déclaration Environnementale et Sanitaire** - is an environmental declaration for construction products that is specific to the French market. Like the EPD, it looks at the entire life cycle of a product and certifies its environmental sustainability and its fitness for building 'green' buildings.

La **FDES – Fiche de Déclaration Environnementale et Sanitaire** - est une déclaration environnementale pour les matériaux de bâtiment spécifique pour le marché français. Tout comme la EPD, elle prend en considération le cycle de vie tout entier des produits et certifie leur éco-durabilité, ainsi que leur compatibilité pour la construction de bâtiments "green".

# FICHE DE DECLARATION ENVIRONNEMENTALE ET SANITAIRE (FDES)



**Carreaux céramiques produits par Ceramiche Refin, Salvaterra (RE) - ITALIE**

Détenteur de la déclaration	Ceramiche Refin, Salvaterra (RE) - ITALIE		
Editeur	BUREAU VERITAS CODDE		
Numéro de déclaration	11-1283:2017		
Publication	01.02.2018	Validité	01.02.2023



**CODDE**

**Déclaration Environnementale Produit conforme à la norme NF EN ISO 14025, NF EN 15804 +A1 et son complément national NF EN 15804 CN**

## INFORMATIONS GENERALES

### Nom du Produit

Référence Commerciale : Carreaux céramiques produits par Ceramiche Refin, Salvaterra (RE) - ITALIE

### Nom du Fabricant déclarant

Ceramiche Refin, Via G. Ambrosoli, 2 42013 Salvaterra (RE) - ITALIE

### Domaine d'application

Cette déclaration et le rapport d'accompagnement associé sont représentatifs du produit, carreaux pour sols et pour mur en grès cerame vitrifié.

Fabricant en Italie et utilisation en France

### Unité Fonctionnelle

« Couvrir et décorer 1m<sup>2</sup> de sol en intérieur ou en extérieur en accord avec les contraintes normatives en termes d'installation pendant 50 ans »

### Emetteur de la déclaration

Bureau Veritas CODDE

170 rue de Chatagnon

38430 Moirans

Tél : +33 (0)4 76 07 36 46

E-mail : [codde@fr.bureauveritas.com](mailto:codde@fr.bureauveritas.com)

Web : [www.codde.fr](http://www.codde.fr)



### Vérificateur de la déclaration

EVEA – Nicolas BEALU

Tél : 09 63 48 50 16

E-mail : [contact@evea-conseil.com](mailto:contact@evea-conseil.com)

Web : [www.evea-conseil.com/](http://www.evea-conseil.com/)



Numéro de déclaration :

11-1283:2017

Cette déclaration est basée sur les Règles de Catégories de Produits (RCP) suivantes :

N/A

Type de déclaration : individuelle

Date de publication : 01.02.2018

Date de validité : 01.02.2023

Programme FDES/INIES

Site internet de publication : <http://www.base-inies.fr/inies/Consultation.aspx>



### Vérification :

Les normes NF EN 15804+A1 datée du 26 avril 2014, et NF EN 15804/CN datée du 18 juin 2016 servent de RCP de référence.

Vérification par tierce-partie indépendante en accord avec ISO 14025 et EN 15804 ainsi que les RCP spécifiques citées ci-dessus:

Interne  Externe

I certificati aggiornati sono disponibili sul sito [www.refin.it](http://www.refin.it)  
Updated certificates are available on [www.refin.it](http://www.refin.it)  
Les certificats mis à jour sont disponibles sur le site [www.refin.it](http://www.refin.it)  
Die aktualisierten Zertifikate sind auf der Internetseite [www.refin.it](http://www.refin.it) verfügbar  
De certificaten zijn up-to-date te vinden op onze website [www.refin.it](http://www.refin.it)  
Los certificados actualizados están disponibles en el sitio web [www.refin.it](http://www.refin.it)

L'UPEC è un sistema di classificazione funzionale dei **prodotti da pavimentazione** che attesta se un prodotto sia adeguato all'utilizzo in un certo locale. La lista completa dei prodotti Refin certificati UPEC dall'ente CSTB è disponibile sul sito web aziendale.

UPEC is a functional rating system for **flooring products**, which proves whether a product is suitable for use in a specific area. A full list of Refin products certified as UPEC compliant by CSTB can be consulted on the company's website.

L'UPEC est un système de classement fonctionnel des **produits pour pavage** qui certifie qu'un certain produit est indiqué pour être utilisé dans un certain local. La liste complète des produits Refin certifiés UPEC par l'organisme CSTB est disponible sur le site web de l'entreprise.

**CSTB**  
le futur en construction

Organisme certificateur  
Certification body



## Certificat

### Carreaux céramiques pour revêtements de sol

Le CSTB atteste que les produits mentionnés en annexe sont conformes à des caractéristiques décrites dans le référentiel de certification QB 32 en vigueur après évaluation selon les modalités de contrôle définies dans ce référentiel.

En vertu de la présente décision, le CSTB accorde à :

**La société :** CERAMICHE REFIN SPA  
Via 1° Maggio 22  
IT - 42013 SALVATERRA DI CASALGRANDE (RE) - ITALIE

**Usine :**  
IT - 42013 SALVATERRA DI CASALGRANDE (RE) - ITALIE  
213

le droit d'usage de la marque QB associée au classement UPEC - Carreaux céramiques pour revêtements de sol pour les produits objets de cette décision, pour toute sa durée de validité et dans les conditions prévues par les exigences générales de la marque QB et le référentiel mentionné ci-dessus.



**Décision de reconduction n°213-16.0/17 du 26 septembre 2018.**  
**Cette décision se substitue à la décision n°213-15.2/16 du 26 janvier 2018.**  
Sauf retrait, suspension, ou modification, ce certificat est valable pendant 15 mois.  
Le certificat en vigueur peut être consulté sur le site internet <http://evaluation.cstb.fr> pour en vérifier sa validité.

### CARACTÉRISTIQUES CERTIFIÉES

> Selon la norme EN 14411 :

- Caractéristiques dimensionnelles
- Groupe d'absorption d'eau
- Résistance au gel
- Résistance mécanique à la flexion

> Autres caractéristiques :

- Classement d'usage UPEC :
  - Résistance à l'abrasion
  - Résistance mécanique à la flexion \*
  - Résistance aux chocs
  - Résistance au roulage lourd
  - Résistance aux agents tachants et chimiques
- Caractéristiques dimensionnelles \*

\* Les tolérances du référentiel QB 32 pour ces caractéristiques sont plus exigeantes que celles définies dans la norme EN 14411.

> Autres caractéristiques optionnelles :

- Glissance (classement PN /PC)
- Caractéristiques dimensionnelles D+ (critères beaucoup plus resserrés)

Si le titulaire bénéficie de caractéristiques optionnelles certifiées, celles-ci sont indiquées dans l'annexe du certificat sur la ligne « particularité » propre à chaque série certifiée.

Ce certificat comporte 25 pages.

Correspondants :

Claire Fouillet  
Courriel : [claire.fouillet@cstb.fr](mailto:claire.fouillet@cstb.fr)  
Tél. : 01 64 68 84 42

Franck Mazaud  
Courriel : [franck.mazaud@cstb.fr](mailto:franck.mazaud@cstb.fr)  
Tél. : 01 64 68 88 52

Pour le CSTB  
Pour le Directeur Technique  
  
Yannick LEMOIGNE

#### CENTRE SCIENTIFIQUE ET TECHNIQUE DU BÂTIMENT

84 avenue Jean Jaurès - Champs-sur-Marne - 77447 Marne-la-Vallée cedex 2  
Tél. : +33 (0)1 64 68 82 82 - Fax : +33 (0)1 64 68 89 94 - [www.cstb.fr](http://www.cstb.fr)  
MARNE-LA-VALLÉE / PARIS / GRENOBLE / NANTES / SOPHIA ANTIPOLIS





Organisme certificateur  
Certification body



## Certificat

### Carreaux céramiques pour revêtements de sol

Le CSTB atteste que les produits mentionnés en annexe sont conformes à des caractéristiques décrites dans le référentiel de certification QB 32 en vigueur après évaluation selon les modalités de contrôle définies dans ce référentiel.

En vertu de la présente décision, le CSTB accorde à :

**La société :** CERAMICHE REFIN SPA  
Via 1° Maggio 22  
IT - 42013 SALVATERRA DI CASALGRANDE (RE) - ITALIE

**Usine :** IT - 42013 SALVATERRA DI CASALGRANDE (RE) - ITALIE  
213

le droit d'usage de la marque QB associée au classement UPEC F+ - Carreaux céramiques pour revêtements de sol pour les produits objets de cette décision, pour toute sa durée de validité et dans les conditions prévues par les exigences générales de la marque QB et le référentiel mentionné ci-dessus.



**Décision d'admission n°213-F-0.0/18 du 21 septembre 2018.**

Sauf retrait, suspension, ou modification, ce certificat est valable pendant 15 mois.

Le certificat en vigueur peut être consulté sur le site internet <http://evaluation.cstb.fr> pour en vérifier sa validité.

L'option F+ concerne les carreaux céramiques visant exclusivement la mise en oeuvre sur plot.

### CARACTÉRISTIQUES CERTIFIÉES

**> Selon la norme EN 14411 :**

- Caractéristiques dimensionnelles
- Groupe d'absorption d'eau
- Résistance au gel
- Résistance mécanique à la flexion

**> Autres caractéristiques :**

- Classement d'usage UPEC :
  - Résistance à l'abrasion
  - Résistance mécanique à la flexion \*
  - Résistance au choc répété
  - Résistance aux agents tachants et chimiques
- Caractéristiques dimensionnelles \*

\* Les tolérances du référentiel QB 32 pour ces caractéristiques sont plus exigeantes que celles définies dans la norme EN 14411.

**> Autres caractéristiques optionnelles :**

- Glissance (classement PN /PC)

Si le titulaire bénéficie de caractéristiques optionnelles certifiées, celles-ci sont indiquées dans l'annexe du certificat sur la ligne « particularité » propre à chaque série certifiée.

Ce certificat comporte 2 pages.

**Correspondants :**

Claire Fouillet  
Courriel : [claire.fouillet@cstb.fr](mailto:claire.fouillet@cstb.fr)  
Tél. : 01 64 68 84 42

Franck Mazaud  
Courriel : [franck.mazaud@cstb.fr](mailto:franck.mazaud@cstb.fr)  
Tél. : 01 64 68 88 52

Pour le CSTB  
Pour le Directeur Technique  
  
Yannick LEMOIGNE

**CENTRE SCIENTIFIQUE ET TECHNIQUE DU BÂTIMENT**  
84 avenue Jean Jaurès - Champs-sur-Marne - 77447 Marne-la-Vallée cedex 2  
Tél. : +33 (0)1 64 68 82 82 - Fax : +33 (0)1 64 68 89 94 - [www.cstb.fr](http://www.cstb.fr)  
MARNE-LA-VALLÉE / PARIS / GRENOBLE / NANTES / SOPHIA ANTIPOLIS





# CERTIFICATE FOR CHINA COMPULSORY PRODUCT CERTIFICATION

CERTIFICATION No: 2006112102000127

**NAME AND ADDRESS OF THE APPLICANT:**

**CERAMICHE REFIN S. P. A**  
Via 1 Maggio, 22-42013 Salvaterra Di Casalgrande (RE)-Italy

**MANUFACTURER:**

**CERAMICHE REFIN S. P. A**  
Via 1 Maggio, 22-42013 Salvaterra Di Casalgrande (RE)-Italy

**NAME AND ADDRESS OF THE FACTORY:**

**CERAMICHE REFIN S. P. A**  
Via 1 Maggio, 22-42013 Salvaterra Di Casalgrande (RE)-Italy  
(FACTORY CODE: K000127)

**NAME AND SERIES OF THE PRODUCTS:**

**PORCELAIN TILES**  
(THE LIST IN APPENDIX)

**CERTIFICATION MODE:**

**Factory's Quality Assurance Ability & Check of consistency of the product**  
**+Type inspection +Follow-up inspection**

**THE STANDARDS AND TECHNICAL REQUIREMENTS FOR THE PRODUCTS:**

**CLASS A REQUIREMENTS OF DECORATIVE MATERIALS IN**  
**LIMIT OF RADIONUCLIDES IN BUILDING MATERIALS (GB6566-2010)**

**THIS IS TO CERTIFY THAT THE ABOVE MENTIONED PRODUCTS HAVE QUALIFIED**  
**FOR THE REQUIREMENTS SPECIFIED IN IMPLEMENTATION RULES FOR THE**  
**COMPULSORY CERTIFICATION OF THE DECORATING AND REFURBISHING PRODUCTS**  
**(PORCELAIN TILES) (CNCA-C21-01:2014)**

**VALIDITY FROM: Jul.06, 2006 REVISION DATE: Jan.15, 2020**

**VALID PERIOD: Dec.06, 2019 ~ Dec.05, 2024**

**THE VALIDITY OF THE CERTIFICATE SHALL DEPEND ON THE FOLLOW-UP**  
**INSPECTION BY THE CERTIFICATION BODY AT REGULAR INTERVALS**



No. 11, Sanlihelu, Haidian District, Beijing, P.R. China 100831

Http: [www.gj-c.cn](http://www.gj-c.cn)

**CCC – China Compulsory Certification** è la certificazione di prodotto per la vendita di piastrelle in gres porcellanato in tutto il mercato cinese. La certificazione CCC riguarda requisiti legati alla sicurezza e alla salute dell'utilizzatore finale, ed è rilasciata esclusivamente da istituti accreditati dalle Autorità cinesi. L'elenco aggiornato dei prodotti certificati è disponibile in azienda.

**CCC – China Compulsory Certification** for the sales of porcelain stoneware tiles within the Chinese market. CCC certification refers to the standard requirements relevant to the safety and health of the end user and is granted exclusively by the institutes certified by the Chinese Authorities. The complete list of certified products is available upon request at Head Office.

**CCC – China Compulsory Certification** est la certification de produit pour la vente de carreaux en grès cérame sur la totalité du marché chinois. La certification CCC porte sur des prérequis inhérents à la sécurité et à la santé du consommateur, elle ne peut être délivrée que par des instituts accrédités par les Autorités chinoises. La liste complète des produits certifiés est à votre disposition auprès de nos bureaux.

A series of horizontal dotted lines for writing notes.





# Color shading

368/369

## Stonalizzazione/Color shading/Denuancement/Farbabweichung/ Kleurnuanceringen/Destonificación

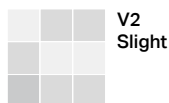

V2  
Slight

Bluetech  
Bricklane  
Chevron Bianchi  
Chevron Vieilli  
Chevron Charme  
Chevron Foncé  
Creos  
Deck Dawn  
Deck Flare  
Essence  
Flake  
Foil  
Fornace  
Fusion  
Gaja  
Graffiti  
Grecale  
Petrae Guyana Almond  
Petrae Guyana Ivory  
Prestigio Carrara  
Risseu  
Trail  
Wide

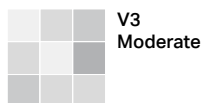

V3  
Moderate

Baita  
Block  
Blue Emotion Flammé  
Deck Blaze  
Deck Bright  
Deck Day  
Deck Dusk  
Deck Night  
Design Industry  
Epoque Beton  
Epoque Bois  
Giant  
Kasai  
Larix  
Mold  
Petrae Muschelkalk Brown  
Petrae Pacific Grey  
Petrae Savoie Ash  
Pietra di Cembra  
Pietre di Borgogna  
Plain  
Poesia  
Prestigio Arcadia  
Prestigio Botticino  
Prestigio Dolomite  
Prestigio Fior di Bosco  
Prestigio Marfil  
Prestigio Tracia  
Prestigio Travertino  
Tune  
Urbex Style

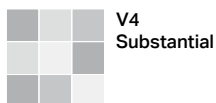

V4  
Substantial

Blue Emotion Scié  
Chevron Gris  
Chevron Huilé  
Chevron Naturel  
Design Industry Raw Mix  
Epoque Beton 30x30/12"x12"  
Epoque Inlay  
Mansion  
Petrae Barge  
Petrae Bavaria  
Plant  
Prestigio Calacatta  
Prestigio Impero  
Prestigio Marquinia  
Prestigio Pulpis  
Prestigio Statuario  
Stardust

### V2 - Slight Variation

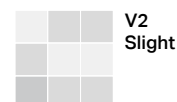

V2  
Slight

Il prodotto è volutamente caratterizzato da una leggera variazione cromatica e di venature, per ricreare la variabilità e la ricchezza dei materiali naturali ai quali la collezione è ispirata. Per le stesse ragioni si consiglia di posare il materiale scegliendolo da più scatole contemporaneamente per garantire la variabilità e casualità della superficie finita. Date le caratteristiche intrinseche del prodotto, i riferimenti cromatici qui presentati sono dunque da ritenersi puramente indicativi.

The slight chromatic variation and the veining of the product is an intrinsic feature to re-create the randomness and richness of the colour shading of natural stones to which the collection is inspired. For these reasons, we recommend installing the product choosing tiles from different boxes in order to guarantee a variable and natural random effect of the finished surface. Due to these intrinsic features of the product, the colours represented in this catalogue must only be considered an example of the many possible colour shades.

Le produit est volontairement caractérisé par une variation légère de la couleur et des veines, pour recréer la variabilité et la richesse des matériaux naturels dont la collection est inspirée. C'est pourquoi il est conseillé de poser le matériau en le choisissant simultanément parmi plusieurs boîtes, afin de garantir la variabilité et l'originalité de la surface finie. En raison des caractéristiques intrinsèques de ce produit, les références chromatiques présentées ici doivent donc être considérées à titre purement indicatif.

Das Produkt wurde gewollt durch eine leichte Variation der Farben und Maserungen geprägt, um die Mannigfaltigkeit und Pracht der natürlichen Materialien wiederzugeben, an denen die Kollektion inspiriert ist. Aus diesem Grund wird auch empfohlen, beim Verlegen Material aus verschiedenen Schachteln zu verwenden, um die Unterschiedlichkeit und Zufälligkeit der fertigen Fläche zu garantieren.

De lichte kleurvariaties en nerftekening zijn gewenste intrinsieke karakteristieken van het product. Zij weerspiegelen de variabiliteit en kracht van natuurlijke materialen, de inspiratiebron van deze collectie. Om deze reden raden wij aan de tegels bij plaatsing uit verschillende dozen te kiezen, ter garantie van een ultiem random en natuurlijk effect voor het eindoppervlak. Gezien de intrinsieke eigenschappen van het product zijn de hier getoonde kleurreferenties zuiver benaderend.

El producto se caracteriza adrede por una leve variación de color y de vetas para recrear la variabilidad y riqueza de los materiales naturales en los que se ha inspirado la colección. Por ello, se aconseja colocar el material eligiéndolo simultáneamente de más de una caja para garantizar la variabilidad y casualidad de la superficie acabada. Dadas las características intrínsecas del producto, las referencias cromáticas que se presentan son puramente indicativas.

### V3 - Moderate Variation

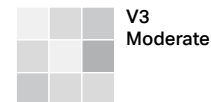

Il prodotto è volutamente caratterizzato da una moderata variazione cromatica e di venature, per ricreare la variabilità e la ricchezza dei materiali naturali ai quali la collezione è ispirata. Per le stesse ragioni si consiglia di posare il materiale scegliendolo da più scatole contemporaneamente per garantire la variabilità e casualità della superficie finita. Date le caratteristiche intrinseche del prodotto, i riferimenti cromatici qui presentati sono dunque da ritenersi puramente indicativi.

The moderate chromatic variation and the veining of the product is an intrinsic feature to re-create the randomness and richness of the colour shading of natural stones to which the collection is inspired. For these reasons, we recommend installing the product choosing tiles from different boxes in order to guarantee a variable and natural random effect of the finished surface. Due to these intrinsic features of the product, the colours represented in this catalogue must only be considered an example of the many possible colour shades.

Le produit est volontairement caractérisé par une variation modérée de la couleur et des veines, pour recréer la variabilité et la richesse des matériaux naturels dont la collection est inspirée. C'est pourquoi il est conseillé de poser le matériau en le choisissant simultanément parmi plusieurs boîtes, afin de garantir la variabilité et l'originalité de la surface finie. En raison des caractéristiques intrinsèques de ce produit, les références chromatiques présentées ici doivent donc être considérées à titre purement indicatif.

Das Produkt wurde gewollt durch eine dezente Variation der Farben und Maserungen geprägt, um die Mannigfaltigkeit und Pracht der natürlichen Materialien wiederzugeben, an denen die Kollektion inspiriert ist. Aus diesem Grund wird auch empfohlen, beim Verlegen Material aus verschiedenen Schachteln zu verwenden, um die Unterschiedlichkeit und Zufälligkeit der fertigen Fläche zu garantieren. Aufgrund der für das Produkt typischen Eigenschaften sind die hier angeführten farblichen Bezugsdaten nur als ungefähre Richtwerte anzusehen.

De gematigde kleurvariaties en nerftekening zijn gewenste intrinsieke karakteristieken van het product. Zij weerspiegelen de variabiliteit en kracht van natuurlijke materialen, de inspiratiebron van deze collectie. Om deze reden raden wij aan de tegels bij plaatsing uit verschillende dozen te kiezen, ter garantie van een ultiem random en natuurlijk effect voor het eindoppervlak. Gezien de intrinsieke eigenschappen van het product zijn de hier getoonde kleurreferenties zuiver benaderend.

El producto se caracteriza adrede por una moderada variación de color y de vetas para recrear la variabilidad y riqueza de los materiales naturales en los que se ha inspirado la colección. Por ello, se aconseja colocar el material eligiéndolo simultáneamente de más de una caja para garantizar la variabilidad y casualidad de la superficie acabada. Dadas las características intrínsecas del producto, las referencias cromáticas que se presentan son puramente indicativas.

### V4 - Substantial Variation



Il prodotto è volutamente caratterizzato da una intensa variazione cromatica e di venature, per ricreare la variabilità e la ricchezza dei materiali naturali ai quali la collezione è ispirata. Per le stesse ragioni si consiglia di posare il materiale scegliendolo da più scatole contemporaneamente per garantire la variabilità e casualità della superficie finita. Date le caratteristiche intrinseche del prodotto, i riferimenti cromatici qui presentati sono dunque da ritenersi puramente indicativi.

The marked chromatic variation and the veining of the product is an intrinsic feature to re-create the randomness and richness of the colour shading of natural stones to which the collection is inspired. For these reasons, we recommend installing the product choosing tiles from different boxes in order to guarantee a variable and natural random effect of the finished surface. Due to these intrinsic features of the product, the colours represented in this catalogue must only be considered an example of the many possible colour shades.

Le produit est volontairement caractérisé par une variation intense de la couleur et des veines, pour recréer la variabilité et la richesse des matériaux naturels dont la collection est inspirée. C'est pourquoi il est conseillé de poser le matériau en le choisissant simultanément parmi plusieurs boîtes, afin de garantir la variabilité et l'originalité de la surface finie. En raison des caractéristiques intrinsèques de ce produit, les références chromatiques présentées ici doivent donc être considérées à titre purement indicatif.

Das Produkt wurde gewollt durch eine starke Variation der Farben und Maserungen geprägt, um die Mannigfaltigkeit und Pracht der natürlichen Materialien wiederzugeben, an denen die Kollektion inspiriert ist. Aus diesem Grund wird auch empfohlen, beim Verlegen Material aus verschiedenen Schachteln zu verwenden, um die Unterschiedlichkeit und Zufälligkeit der fertigen Fläche zu garantieren. Aufgrund der für das Produkt typischen Eigenschaften sind die hier angeführten farblichen Bezugsdaten nur als ungefähre Richtwerte anzusehen.

De intense kleurvariaties en nerftekening zijn gewenste intrinsieke karakteristieken van het product. Zij weerspiegelen de variabiliteit en kracht van natuurlijke materialen, de inspiratiebron van deze collectie. Om deze reden raden wij aan de tegels bij plaatsing uit verschillende dozen te kiezen, ter garantie van een ultiem random en natuurlijk effect voor het eindoppervlak. Gezien de intrinsieke eigenschappen van het product zijn de hier getoonde kleurreferenties zuiver benaderend.

El producto se caracteriza adrede por una intensa variación de color y de vetas para recrear la variabilidad y riqueza de los materiales naturales en los que se ha inspirado la colección. Por ello, se aconseja colocar el material eligiéndolo simultáneamente de más de una caja para garantizar la variabilidad y casualidad de la superficie acabada. Dadas las características intrínsecas del producto, las referencias cromáticas que se presentan son puramente indicativas.



# Technical features

372/373

## Caratteristiche tecniche

### Campionamento e criteri di accettazione UNI EN ISO 10545-1

La Norma stabilisce i criteri per la costituzione dei lotti, per il campionamento, il controllo, l'accettazione e il rifiuto delle piastrelle di ceramica non installate. La Norma fornisce un sistema di controllo basato su un campionamento doppio che distingue un controllo per attributi (valori individuali) e un controllo sul valore medio (variabili). Il numero di piastrelle da sottoporre a prova dipende dalla caratteristica che si vuole controllare.

### Caratteristiche dimensionali e della qualità della superficie UNI EN ISO 10545-2

La Norma definisce i metodi per determinare le caratteristiche dimensionali (lunghezza, larghezza, spessore, rettilineità degli spigoli, ortogonalità, planarità) e la qualità della superficie della piastrella ceramica. Si usano calibri a cursore o altri strumenti adatti per misure lineari, devono essere misurate 10 piastrelle intere per ogni tipo e occorre misurare le con precisione di 0,1 mm ogni lato del pezzo in esame alla distanza di 5 mm dagli angoli.

### Assorbimento acqua UNI EN ISO 10545/3

L'assorbimento è l'attitudine che ha il prodotto ceramico a lasciarsi penetrare dall'acqua. È facile comprendere come tale fenomeno sia di grande importanza per la determinazione delle caratteristiche e qualità meccaniche del prodotto. Per questo le norme europee CEN suddividono le piastrelle pressate secondo la percentuale d'assorbimento dividendole in cinque gruppi: ANNEX G, H, J, K, L.

### Resistenza alla flessione UNI EN ISO 10545/4

La resistenza alla flessione è un valore limite di carico applicato su tre punti che la piastrella può sopportare senza arrivare a frattura. Il valore viene espresso in N/mm<sup>2</sup> e la norma ISO 10545/4 stabilisce i valori minimi di accettabilità come segue:  
Blb 35  
Blla 30  
Blb1 18

### Coefficiente di restituzione (COR) UNI EN ISO 10545/5

La prova fornisce una indicazione della resistenza all'urto delle piastrelle mediante il coefficiente di restituzione mediante la caduta di una biglia di acciaio da altezza prefissata e misurando l'altezza del rimbalzo. L'appendice P della norma 14411 fornisce un valore indicativo di 0,55 per piastrelle sottoposte a basse sollecitazioni ma non pone limiti da rispettare.

### Resistenza all'abrasione profonda UNI EN ISO 10545/6 (piastrelle colorate in massa ovvero denominate ugli)

Metodo applicabile alle sole piastrelle di ceramica non smaltate. Il metodo di prova e l'espressione dei risultati sono uguali a quelli riportati nelle precedenti Norme Europee (EN 102). È stata apporata solo una modifica per quanto riguarda il materiale da usare per la calibrazione dello strumento. La procedura di taratura rimane invariata.

### Resistenza all'abrasione UNI EN ISO 10545/7 (piastrelle smaltate ovvero denominate gll)

La resistenza all'abrasione è la capacità della superficie dello smalto di resistere all'azione di usura provocata dal camminamento o dallo sfregamento di corpi

meccanici (carrelli, ecc.). Tale azione d'usura è strettamente collegata all'agente meccanico (suola di cuoio, suola di cuoio, ecc.); al materiale d'apporto (acqua, sabbia, fango, ecc.) e all'intensità di traffico. Secondo la norma, le piastrelle vengono classificate secondo la loro destinazione d'uso in queste classi:  
**PEI I** Prodotti destinati ad ambienti sottoposti a traffico leggero e senza sporco abrasivo; es. bagni, camere da letto  
**PEI II** Prodotti destinati ad ambienti sottoposti a traffico medio e ad azione abrasiva medio-bassa; es. studi, soggiorni  
**PEI III** Prodotti destinati ad ambienti sottoposti a traffico medio forte con azione abrasiva media; es. ingressi, cucine di case private  
**PEI IV** Prodotti destinati ad ambienti sottoposti a traffico intenso; es. ristoranti, uffici, negozi, uffici pubblici (ad esclusione dei pavimenti sottostanti casse e banchi di pubblici esercizi e passaggi ristretti obbligati)  
**PEI V** Prodotti destinati ad ambienti sottoposti a traffico particolarmente intenso.

### Coefficiente di dilatazione termica lineare UNI EN ISO 10545/8

La prova fornisce il valore del coefficiente di dilatazione delle piastrelle di ceramica al variare della temperatura. Il coefficiente di dilatazione termica lineare è determinato nell'intervallo di temperatura fra quella ambiente e 100°C.

### Resistenza allo sbalzo termico UNI EN ISO 10545/9

La resistenza allo sbalzo termico è la capacità della superficie dello smalto di non subire alterazioni visibili allo "shock" derivante dalla differenza di temperatura procurata con cicli successivi di immersione in acqua a temperatura ambiente a stazionamento in stufa

a temperature maggiori di 105°C. Viene indicato se la piastrella resiste o meno.

### Dilatazione all'umidità UNI EN ISO 10545/10

La norma stabilisce un metodo per determinare la dilatazione dovuta all'umidità della piastrella in ceramica mediante l'immersione di una piastrella riscaldata in acqua bollente e misura delle variazioni proporzionali di lunghezza. La maggior parte della piastrelle hanno dilatazioni trascurabili all'umidità, tuttavia una dilatazione all'umidità che superi lo 0,06% (0,6mm/m) può contribuire all'insorgere di problemi

### Resistenza al gelo UNI EN ISO 10545/12

La resistenza al gelo è la caratteristica che devono possedere le piastrelle in presenza di acqua a temperature inferiori a 0°C, ovvero di non subire danneggiamenti per le tensioni legate all'aumento di volume dell'acqua per congelamento. Viene indicato se la piastrella resiste.

### Resistenza chimica UNI EN ISO 10545/13

La resistenza chimica è la capacità dello smalto di tollerare a temperatura ambiente il contatto con sostanze chimiche (di uso domestico, macchianti, additivi per piscine, acidi e basi) senza subire alterazioni di aspetto.

### Determinazione della resistenza alle macchie UNI EN ISO 10545/14

Metodo applicabile a tutte le superfici di esercizio delle piastrelle di ceramica per determinare la resistenza alle macchie. Ognuno degli agenti macchianti deve essere mantenuto per 24 ore su almeno 5 campioni di prova la cui superficie di esercizio

è stata preventivamente pulita ed essicata. La rimozione degli agenti macchianti avviene per fasi successive avvalendosi di diversi agenti pulitori e procedure di pulizia.

**Classe 5:** la macchia viene rimossa con acqua calda

**Classe 4:** la macchia viene rimossa con agente pulitore commerciale debole

**Classe 3:** la macchia viene rimossa con agente pulitore commerciale forte

**Classe 2:** la macchia viene rimossa con solventi quali ad esempio l'acetone

### Cessione di piombo e cadmio UNI EN ISO 10545/15

La prova fornisce indicazione della quantità di piombo e cadmio ceduti dallo smalto delle piastrelle ceramiche. La prova viene eseguita esponendo la superficie della piastrella ad una soluzione di acido acetico.

### Resistenza al fuoco

Il comportamento di un materiale che contribuisce con la propria decomposizione al fuoco a cui è sottoposto in condizioni determinate. (UNI CEI EN ISO 13943 : 2004). La reazione al fuoco di un materiale viene convenzionalmente espressa in classi. La ceramica è classificata in classe A1 (prodotti incombustibili).

### Indicazione di resistenza allo scivolamento

→ Indice DIN 51130 "R" di resistenza allo scivolamento, in funzione dell'angolo di inclinazione con cui una persona fisica che cammina sul piano inclinato non è più in grado di mantenere l'equilibrio.  
→ Coefficiente di attrito dinamico secondo la norma B.C.R.A. Rep. CEC/81  
→ Coefficiente di attrito dinamico secondo standard ANSI A137.1-2012 (BOT3000)

→ Coefficiente di attrito secondo norma BS 7976-2:2002 (CEN/TS 16165, Annex C) Pendulum Friction Test.

## Technical features

### Sampling and acceptance criteria UNI EN ISO 10545-1

The Regulation lays down criteria on batching, sampling, inspection, acceptance and rejection of ceramic tiles before installation. The Regulation provides a double-sampling testing method, where attributes (individual results) and mean values (variables) are separately tested. The number of tiles to be tested depends on which specifications the test is intended to measure.

### Dimensional and surface quality specifications UNI EN ISO 10545-2

The Regulation describes methods for the measurement of the dimensional specifications (length, width, thickness, straightness, right angles, level) and surface quality of ceramic tiles. Slide calipers or other suitable instruments are used to take linear measurements; 10 whole tiles per type must be tested, and each side of each tile must be measured to 0.1mm accuracy, 5mm from the corners.

### Water absorption UNI EN ISO 10545/3

Absorption is the ceramic product capacity for water penetration. Obviously, this is greatly important for the determination of the product mechanical features. The CEN European Regulations subdivide pressed tiles into five groups according to their absorption percentage: ANNEX G, H, J, K, L.

### Bending resistance UNI EN ISO 10545/4

Bending resistance is the maximum load applied at three points that the tile can bear without breaking. The

level is expressed in N/mm<sup>2</sup> and ISO 10545/4 standard defines the following minimum acceptable settings:  
Blb 35  
Blla 30  
Blbb 18

### Coefficient of restitution (COR) UNI EN ISO 10545/5

The coefficient of restitution measures the tile impact resistance by dropping a steel ball from a fixed height and measuring the height of rebound. Annex P of Standard 14411 recommends a value of 0.55 for tiles undergoing light impacts but it does not set limits to be respected.

### Deep abrasion resistance UNI EN ISO 10545/6 (full-body coloured ceramic tiles classified as ugl)

Method only applicable to unglazed ceramic tiles. The testing method and the expression of results are the same as those indicated in the previous European Standards (EN 102). Only one modification has been made regarding the material to be used for the calibration of the instrument. The calibration procedure remains unchanged.

### Abrasion resistance UNI EN ISO 10545/7 (glazed ceramic tiles classified as gl)

Abrasion resistance is the capacity of the glazed surface to resist the wear caused by foot traffic or the abrasion caused by mechanical equipment (lift trucks, etc.). The wear action is strictly linked to the mechanical agent (rubber sole, leather sol, etc.), the material carried on to the surface (water, sand, mud, etc.) and classified in five categories depending on the areas they are used in:  
**PEI I** Tiles for areas with light traffic and without abrasive dirt, e.g. bath-

rooms, bedrooms  
**PEI II** Tiles for areas with average traffic and medium to low abrasion, e.g. studying rooms, living rooms

**PEI III** Tiles for areas with high medium to high traffic and average abrasion, e.g. foyer, kitchen in private residences

**PEI IV** Tiles for areas with intense traffic, e.g. restaurants, offices, shops, public offices (excluding floors under cash desks and shop counters and narrow unavoidable passageways)

**PEI V** Tiles for areas with especially intense traffic

### Coefficient of thermal linear expansion UNI EN ISO 10545/8

The test determines the coefficient of expansion of the ceramic tiles according to temperature changes. The coefficient of linear thermal expansion is set within the range of temperatures from ambient temperature to 100°C.

### Resistance to thermal shock UNI EN ISO 10545/9

Resistance to thermal shock is the capacity of a glazed surface not to suffer visible alteration because of the "shock" caused by difference in temperature. The test involves a number of repeated cycles with the tile immersed in water at room temperature, after which it is placed in an oven at temperature higher than 105°C. On the basis of the test, the tile is defined as resistant or not.

### Dilatation due to humidity UNI EN ISO 10545/10

This standard sets a method to determine dilatation due to humidity in the tile by dipping one tile (heated in boiling water). Afterwards it is possible to measure proportional length changes. Most tiles show minimum humidity dilatation – anyway, humidity dilata-

tion exceeding 0.06% (0.6mm/m) may give rise to problems.

### Frost resistance UNI EN ISO 10545/12

Frost resistance is a quality tiles have when are subjected to water at temperatures lower than 0°C without being damaged by stress generated by their moisture content freezing. The tiles are defined as resistance or not.

### Resistance to chemicals UNI EN ISO 10545/13

Resistance to chemicals is the capacity of the glaze at room temperature to tolerate contact with chemicals (domestic products, staining chemicals, pool additives, acids and solvents) without alteration in its appearance.

### Determination of resistance to stains UNI EN ISO 10545/14

Method applicable to all working surfaces of ceramic tiles to determine their resistance to stains. Each staining agent must remain on at least 5 testing samples, for at least 24 hours, whose working surfaces has been cleaned and dried beforehand. Removal of the staining agents takes place in subsequent steps using various cleaning agents and (cleaning procedures).

**Class 5:** the stain is removed using hot water

**Class 4:** the stain is removed using a weak commercial cleaning agent

**Class 3:** the stain is removed using a strong commercial cleaning agent

**Class 2:** the stain is removed using solvent, such as acetone for example

### Lead and cadmium discharge UNI EN ISO 10545/15

This test determines the quantity of lead and

cadmium released by the glaze of ceramic tiles. The test is made by exposing the surface of tiles to an acetic acid solution.

### Fire resistance

This is the behaviour of a given material that by its decomposition contributes to the fire affecting it under particular conditions. (UNI CEI EN ISO 13943 : 2004). The reaction to fire of a material is usually expressed in classes. Ceramic is usually included in Class A1 (non combustible materials).

### Assessment of slip resistance

→ DIN 51130 "R" Index of slip resistance, depending on the angle of inclination at which a person walking on an inclined plane cannot keep his balance.

→ Measurement of dynamic friction coefficient in compliance with the B.C.R.A. Rep. CEC/81 standard  
→ Dynamic friction coefficient to standard ANSI A137.1-2012 (BOT3000)  
→ Friction coefficient to standard BS 7976-2:2002 (CEN/TS 16165, Annex C) Pendulum Friction Test.



## Caractéristiques Techniques

### Échantillonnage et conditions de réception UNI EN ISO 10545-1

La norme établit les critères pour la constitution des lots, l'échantillonnage, le contrôle, l'acceptation et le rejet des carreaux céramiques non posés. La norme fournit un système de contrôle basé sur un double échantillonnage qui distingue un contrôle pour les spécificités (valeurs individuelles) et un contrôle sur la valeur moyenne (variables). Le nombre de carreaux à soumettre à l'essai dépend de la caractéristique que l'on entend contrôler.

### Caractéristiques dimensionnelles et de la qualité de surface UNI EN ISO 10545-2

La norme définit les méthodes pour la détermination des caractéristiques dimensionnelles (longueur, largeur, épaisseur, rectitude des arêtes, angularité et planéité) et de la qualité de surface du carreau céramique.

On utilise des calibres à coulisse, ou d'autres instruments adaptés aux mesures linéaires, et il faut mesurer 10 carreaux entiers pour chaque type, et mesurer chaque côté du carreau en examen avec une précision de 0,1 mm par rapport à une distance de 5 mm des arêtes.

### Absorption d'eau UNI EN ISO 10545/3

Le produit céramique a tendance à être pénétré par l'eau, ce que l'on entend par absorption. Comme l'on peut aisément comprendre, ce phénomène est très important pour déterminer les caractéristiques et les qualités mécaniques du produit. C'est pour cela que les normes européennes CEN répartissent les carreaux pressés en raison du pourcentage

d'absorption en 5 groupes: ANNEX G, H, J, K, L.

### Résistance à la flexion UNI EN ISO 10545/4

La résistance à la flexion est la valeur limite de charge appliquée en 3 points sans que le carreau arrive à sa rupture. La valeur est exprimée en N/mm<sup>2</sup> et la norme ISO 10545/4 définit les valeurs minimales acceptées, de la manière suivant: Blb 35 Blla 30 Bllb 18

### Coefficient de restitution (COR) UNI EN ISO 10545/5

L'essai du coefficient de restitution détermine la résistance au choc des carreaux. Il est réalisé en faisant tomber une bille en acier d'une hauteur prédéfinie et en mesurant le rebond. L'Annexe P de la Norme 14411 préconise une valeur indicative de 0,55 pour des carreaux soumis à des chocs faibles mais aucune limite n'est établie.

### Résistance à l'abrasion profonde UNI EN ISO 10545/6

(carreaux colorés pleine masse également dénommés UGL) Méthode applicable uniquement aux carreaux de céramique non émaillés. La méthode d'essai et l'expression des résultats sont identiques à celles reportées dans les précédentes Normes Européennes (EN 102). La seule modification apportée est celle qui concerne le matériau à utiliser pour le calibrage de l'instrument. La procédure de mise reste inchangée.

### Résistance à l'abrasion UNI EN ISO 10545/7

(carreaux émaillés également dénommés GL) La résistance à l'abrasion est la capacité de

la surface de l'émail de résister à l'action d'usure provoquée par le cheminement ou par le frottement de corps mécaniques (chariots, etc.). Cette action d'usure est étroitement liée au type d'agent mécanique (semelle de caoutchouc, semelle de cuir, etc.); au matériel d'apport (eau, sable, boue, etc.) et à l'intensité du trafic. D'après la norme, les carreaux font partie des cinq classes ci-dessous, suivant leur destination d'utilisation: PEI I Produits destinés à des locaux soumis à un trafic léger et sans saleté abrasive: ex salles de bains, chambres à coucher

PEI II Produits destinés à des locaux soumis à un trafic moyen et à une abrasion moyenne-basse: ex. salles d'études et de séjour

PEI III Produits destinés aux locaux soumis à un trafic moyen fort avec action abrasive moyenne: ex entrées, cuisines de maisons privées

PEI IV Produits destinés aux locaux soumis à un trafic intense: ex. restaurants, bureaux, magasins, lieux publics (à l'exception des sols sous les caisses, sous les comptoirs des établissements publics et des passages étroits obligatoires...)

PEI V Produits destinés aux locaux soumis à un trafic particulièrement intense

### Coefficient de dilatation thermique linéaire UNI EN ISO 10545/8

Cet essai détermine le coefficient de dilatation des carreaux céramiques selon les variations de température. Le coefficient de dilatation thermique linéaire se trouve dans l'intervalle entre la température ambiante et 100°C.

### Résistance aux variations thermiques UNI EN ISO 10545/9

La résistance aux variations thermiques est la capacité de la surface

de l'émail de ne pas subir d'altération visibles au "choc" dérivant de la différence de température procurée par des cycles répétés d'immersion dans de l'eau, à température ambiante et de stationnement dans une étuve à une température de plus de 105°C. Ce test indique si le carreau est résistant.

### Dilatation à l'humidité UNI EN ISO 10545/10

Cette norme définit une méthode pour déterminer la dilatation due à l'humidité des carreaux céramique moyennant l'immersion d'un carreau réchauffé en eau bouillante suivie de la mesure des changements proportionnels en longueur. La plupart des carreaux ont des dilatations négligeables à l'humidité – toutefois une dilatation à l'humidité dépassant 0,06% (0,6mm/m) pose des problèmes.

### Résistance au gel UNI EN ISO 10545/12

La résistance au gel est la caractéristique que les carreaux peuvent évincer en présence d'eau à des températures inférieures à 0°C, et celle de ne pas subir de dégâts à cause de tensions dérivants de l'augmentation du volume de l'eau par congélation. Ce test indique si le carreau est résistant.

### Résistance chimique UNI EN ISO 10545/13

La résistance chimique est la capacité de l'émail de tolérer, à température ambiante, le contact avec les produits chimiques (à usage domestique, additifs pour piscines, acides et alcalis) sans subir aucune altération d'aspect.

### Détermination de la résistance aux taches UNI EN ISO 10545/14

Méthode applicable à toutes les surfaces de

travail des carreaux de céramique afin de déterminer leur résistance aux taches. Chaque agent tachant doit être gardé pendant 24 heures, sur au moins 5 échantillons d'essai, dont la surface de travail a été, au préalable, nettoyée et séchée. Les agents tachants sont ensuite enlevés au moyen de divers détergents et procédures de nettoyage.

**Catégorie 5:** la tache s'enlève à l'eau chaude

**Catégorie 4:** la tache s'enlève au moyen de détergents doux, en vente dans le commerce

**Catégorie 3:** la tache s'enlève au moyen de détergents forts, en vente dans le commerce

**Catégorie 2:** la tache s'enlève au moyen de solvants, tels que l'acétone

### Perte de plomb et cadmium UNI EN ISO 10545/15

L'essai détermine la quantité de plomb et de cadmium dégagée par l'émail des carreaux céramiques et il est réalisé en exposant la surface des carreaux à une solution d'acide acétique.

### Résistance au feu

C'est la manière dont un matériau va se comporter comme combustible. (UNI CEI EN ISO 13943: 2004). La réaction au feu d'un matériau est traditionnellement exprimée en classes. La céramique se trouve dans la Classe A1 (produits incombustibles).

### Indication de la résistance au glissement

→ Indice DIN 51130 "R" de résistance au glissement, en fonction de l'angle d'inclinaison où une personne physique qui marche sur le plan incliné n'est plus en mesure de rester en équilibre.  
→ Mesure du coefficient de frottement dynamique selon norme B.C.R.A. Rep. CEC/81

→ Coefficient de frottement dynamique suivant le standard ANSI A137.1-2012 (BOT3000)

→ Coefficient de frottement suivant la norme BS 7976-2:2002 (CEN/TS 16165, Annexe C) Pendulum Friction Test.

## Technische Eigenschaften

### Probenahme und Grundlagen für die Annahme UNI EN ISO 10545-1

Die Richtlinie bestimmt die Kriterien für die Zusammenstellung der Lose und für die Probenahme, Kontrolle, Annahme und Ablehnung nicht verlegter Keramikfliesen. Die Richtlinie enthält ein Prüfsystem auf Grundlage einer doppelten Probenahme. Dabei wird zwischen einer Prüfung nach Attributen (individuelle Werte) und nach dem Mittelwert (Variablen) unterschieden. Die Anzahl der zu prüfenden Fliesen ist von dem zu prüfenden Merkmal abhängig.

### Maße und Oberflächenbeschaffenheit UNI EN ISO 10545-2

Die Richtlinie definiert die Methoden zur Bestimmung der Abmessungen (Länge, Breite, Stärke, Geradheit der Seiten, Rechtwinkligkeit, Ebenföchigkeit) und der Oberflächenqualität der Keramikfliese. Es werden Schieblehren oder andere, für lineare Messungen geeignete Instrumente verwendet. Je Typ sind 10 ganze Fliesen zu vermessen, und die Messungen sind mit 0,1 mm Genauigkeit an jeder Seite des zu prüfenden Stücks in 5 mm Abstand von den Ecken vorzunehmen.

### Wasseraufnahme UNI EN ISO 10545/3

Die Wasseraufnahme ist das Verhalten eines keramischen Produktes im Kontakt mit Wasser, dasselbe in sich aufzusaugen. Es versteht sich von selbst, wie wichtig dieses Verhalten hinsichtlich Bestimmung der mechanischen Eigenschaften und Qualitäten des Produktes ist. Aus diesem Grunde unterteilen die europäischen CEN-Normen gepresste Fliesen nach

dem Prozentsatz der Wasseraufnahme in 5 Gruppen: ANNEX G, H, J, K, L.

### Biegezugfestigkeit UNI EN ISO 10545/4

Die Biegezugfestigkeit ist der Grenzwert der Druckbelastung, die an 3 Stellen angelegt wird und nicht zum Bruch der Fliese führen darf. Der Wert wird in N/mm<sup>2</sup> ausgedrückt und die ISO-Norm 10545/4 setzt für die unterschiedlichen Produktklassen folgende Mindestwerte fest:

Bib 35  
Blla 30  
Blb 18

### Restitutionskoeffizienten (COR) UNI EN ISO 10545/5

Dieser Test bestimmt die Schlagfestigkeit der Fliesen, ermittelt anhand des Kugelrückprall Testes: eine Stahlkugel fällt aus einer festgelegten Höhe und die Höhe des Rückpralls wird gemessen. Anhang P der Norm 14411 empfiehlt ein Richtwert von 0,55 für Fliesen, die leichte Aufprallkräfte absorbieren aber keine bindenden Grenzwerte festgelegt sind.

### Tiefenabriebfestigkeit UNI EN ISO 10545/6 (durchgefärbte fliesen bzw. so genannte UGL)

Diese nur auf unglasierte Keramikfliesen anzuwendende Prüfmethode, entspricht hinsichtlich Ergebnis und Verfahren der ursprünglichen Europäischen Norm (EN 102). Es wurde nur das zu verwendende Kalibrierungsmaterial des Instruments verändert. Das Eichverfahren selbst blieb unverändert.

### Abriebbeständigkeit UNI EN ISO 10545/7 (glasierte fliesen bzw. So genannte GL)

Unter Abriebbeständigkeit versteht man die Fähigkeit der Glasur-

oberfläche, gegenüber der verschleissenden Wirkung, die durch das Begehen oder Reiben mit mechanischen Gegenständen (Wagen etc.) verursacht wird, beständig zu sein. Die verschleissende Wirkung steht in engem Zusammenhang mit dem Material, welches die mechanische Reibung (Gummi-sole, Ledersohle, etc.) ausübt, bzw. welches die Reibung verstärkende Mittel (Wasser, Sand, Schlamm etc.) vorhanden ist. Außerdem spielt auch das Verkehrsaufkommen eine große Rolle. Nach der Norm werden die Fliesen je nach ihrer Bestimmung in fünf Klassen eingeteilt:

**PEI I** Produkte, die für Raube mit geringer Gehbelastung und ohne abreibenden Schmutz bestimmt sind, wie Badezimmer, Schlafzimmer  
**PEI II** Produkte, welche in Räumen mit mittlerer Gehbelastung und mittel bis niedriger reibender Schmutzbelastung zum Einsatz kommen, Arbeitszimmer, Wohnzimmer  
**PEI III** Produkte, welche in Räumen mit mittel bis höherer Gehbelastung und mittlerer, reibender Schmutzbelastung zum Einsatz kommen, wie Eingänge, Küchen in Privathäusern  
**PEI IV** Produkte, welche in Räumen mit hoher Gehbelastung zum Einsatz kommen, Restaurants, Büros, Ladenlokale, öffentliche Ämter (mit Ausnahme der Bodenbeläge unter Kasernen und Verkaufstheken von Geschäften und engen Passagen)  
**PEI V** Produkte, die für Räume mit besonders intensiver Gehbelastung bestimmt sind

### Wärmeausdehnungskoeffizient UNI EN ISO 10545/8

Dieser Kennwert beschreibt das Verhalten der Keramikfliesen bezüglich Veränderungen seiner Abmessungen bei Temperaturveränderungen. Der thermische Ausdehnungskoeffizient wird zwischen Raumtemperatur und 100 °C ermittelt.

### Temperaturwechselbeständigkeit UNI EN ISO 10545/9

Die Temperaturwechselbeständigkeit wird als die Fähigkeit der Glasur-oberfläche bezeichnet, wodurch bei abwechselndem Aufwärmen der Fliese im Ofen auf mindestens 105 °C und nachfolgendem Eintauchen in Wasser bei Zimmertemperatur, der bewirkte Temperaturschock keine sichtbaren Beschädigungen hervorruft. Es wird angegeben, ob die Fliese beständig ist, oder nicht.

### Feuchtedehnung Nach UNI EN ISO 10545/10

Die Norm gibt eine Methode zur Bestimmung der Feuchtedehnung von Keramikfliesen vor, bei der eine erwärmte Fliese in siedendes Wasser getaucht und anschließend gemessen wird, um die proportionalen Längenveränderungen zu ermitteln. Die meisten Fliesen weisen eine unbedeutende Feuchtedehnung auf. Ein Wert über 0,06 % (0,6 mm/m), kann jedoch zu Problemen führen.

### Frostbeständigkeit UNI EN ISO 10545/12

Die Frostbeständigkeit ist jene Eigenschaft, wodurch Fliesen im Kontakt mit Wasser bei Temperaturen unter 0 °C, trotz der durch die Volumenerhöhung des gefrierenden Wasser bedingten Spannungen, keine Schäden aufweisen. Es wird angegeben, ob die Fliese beständig ist, oder nicht.

### Beständigkeit gegenüber chemikalien UNI EN ISO 10545/13

Unter Beständigkeit gegenüber Chemikalien versteht man die

Fähigkeit der Glasur, bei Raumtemperatur dem Kontakt mit Chemikalien (Haus-haltsreiniger, Fleckentferner, Zusatzstoffe für Schwimmbecken, Säuren und Laugen) standzuhalten, ohne ihr Aussehen zu verändern.

### Bestimmung der fleckenbeständigkeit UNI EN ISO 10545/14

Methode, welche auf allen Oberflächen keramischer Fliesen zur Anwendung gebracht wird, um deren Beständigkeit gegen Fleckeneinwirkung zu bestimmen. Alle fleckerzeugenden Mittel müssen 24 Stunden lang auf mindestens 5 Versuchsmuster einwirken, deren Oberfläche zuvor gereinigt und getrocknet worden ist. Die Entfernung der fleckerzeugenden Mittel erfolgt in den nachfolgenden Phasen unter Anwendung unterschiedlicher Reinigungsmittel und Reinigungsverfahren.  
**KLASSE 5:** der Fleck wird mit warmem Wasser entfernt werden  
**KLASSE 4:** der Fleck wird mit einem schwachen handelsüblichen Reinigungsmittel entfernt  
**KLASSE 3:** der Fleck wird mit einem starken handelsüblichen Reinigungsmittel entfernt  
**KLASSE 2:** der Fleck wird mit Lösungsmitteln, wie z. B. Azeton, entfernt

### Abgabe von Blei und Cadmium UNI EN ISO 10545/15

Die glasierte Oberfläche wird einer Essigsäure-Lösung ausgesetzt. Anschließend wird die Menge des abgegebenen Bleis und Cadmiums gemessen.

### Feuerwiderstands

Merkmal zur Beurteilung des Brandverhaltens von Bauteilen (UNI CEI EN ISO 13943 : 2004). Sie werden in Klassen eingeteilt. Fliesen haben die Klassifizierung „Brandklasse A1“.

(unbrennbar).

### Bestimmung der trittsicherheit

→ Der DIN 51130 "R"-Wert der Trittsicherheit, wird durch Messung des Neigungswinkels einer schiefen Ebene bestimmt, auf welcher eine Person geht und nicht mehr in der Lage ist, das Gleichgewicht zu halten.  
→ Dynamischer Reibungskoeffizient gemäß B.C.R.A. Rep. CEC/81 Norm  
→ Dynamischer Reibungskoeffizient gemäß Standard ANSI 137.1:2012  
→ Reibungskoeffizient gemäß Norm BS 7976-2:2002 (CEN/TS 16165, Annex C) Pendulum Friction Test.

## Technische eigenschappen

### Bemonstering en aanvaardingscriteria UNI EN ISO 10545-1

De Norm stelt de criteria vast voor de samenstelling van partijen, voor de bemonstering, de controle, de aanvaarding, en de weigering van niet-gelegde keramiektegels.

De Norm biedt een controlesysteem gebaseerd op dubbele bemonstering waarbij zowel de attributen (individuele waarden) als de gemiddelde waarde (variabelen) worden gecontroleerd. Het aantal tegels dat wordt getest hangt af van het te controleren kenmerk.

### Kenmerken van de afmetingen en de kwaliteit van de oppervlakken UNI EN ISO 10545-2

De Norm definieert de methodes om de afmetingen (lengte, breedte, dikte, rechtheid van de hoeken, rechthoekigheid, vlakheid) en de kwaliteit van het oppervlak van de keramiektegel vast te stellen. Daarbij worden schuifmaten of andere lengtemeetinstrumenten waarmee gebruikt; van elk type worden 10 hele tegels gemeten, en elke zijde wordt op 5 mm afstand van de hoeken gemeten met een nauwkeurigheid van 0,1 mm.

### Waterabsorptie UNI EN ISO 10545/3

De absorptie is de neiging die het keramische product heeft er water in door te laten dringen. Het is duidelijk dat dit fenomeen van groot belang is voor de eigenschappen en de mechanische kwaliteiten van het product. Om deze redenen delen de Europese CEN-normen de tegels in volgens het absorptiepercentage, door ze te verdelen in vijf groepen: BIJLAGE G, H, J, K, L.

### Buigvastheid UNI EN ISO 10545/4

De buigvastheid is demaximale belasting-waarde die op drie punten van de tegel wordt uitgeoefend zonder dat hij breekt. De waarde wordt uitgedrukt in N/mm<sup>2</sup> en de ISO-norm 10545/4 bepaalt de minimale aanvaardbare waarden als volgt: Blb 35 Blba 30 Blb 18

### Restitutiecoëfficiënt (COR) UNI EN ISO 10545/5

Deze test geeft een indicatie van de stootvastheid van de tegels in de vorm van een restitutiecoëfficiënt, door een stalen knikker vanuit een vooraf vastgestelde hoogte te laten vallen en te meten hoe hoog de knikker opstuit. Bijlage P van standaard 14411 geeft een indicatieve waarde van 0,55 voor laag belaste tegels maar stelt geen limieten

### Weerstand tegen afschuring UNI EN ISO 10545/6 (door-en-door-gekleurde tegels met specificatie UGL)

Methode die uitsluitend kan worden toegepast op niet-geglazuurde keramiektegels. De testmethodes en de weergave van de resultaten zijn hetzelfde als die in de vorige Europese normen (EN 102). Er is slechts één wijziging aangebracht met betrekking tot het te gebruiken materiaal voor het kalibreren van het instrument. De ijkingsprocedure blijft hetzelfde.

### Weerstand tegen afschuring UNI EN ISO 10545/7 (geglazuurde tegels met specificatie GL)

De weerstand tegen afschuren is de capaciteit van het oppervlak van het glazuur om bestand te zijn tegen de slijtage die wordt veroorzaakt door het lopen of het schuren van

mechanische voorwerpen (karren etc.). Deze slijtage hangt nauw samen met het mechanische middel (rubberen zool, leren zool, etc.), het meegevoerd materiaal (water, zand modder, etc.) en de intensiteit van de belasting. De norm bepaalt dat de tegels volgens hun gebruiksbestemming worden geïnclassificeerd in deze klassen:

**PEI I** Producten bestemd voor ruimten met lichte belasting en zonder schurende voorwerpen; bijv. badkamers, slaapkamers

**PEI II** Producten bestemd voor ruimten met gemiddelde belasting en een gemiddelde/lichte schurende werking; bijv. studeerkamers, woonkamers

**PEI III** Producten bestemd voor ruimten met een gemiddelde/zware belasting met een gemiddelde schurende werking; bijv. ingangen, keukens van woningen

**PEI IV** Producten bestemd voor ruimten met zware belasting; bijv. restaurants, kantoren, winkels, openbare instanties (met uitzondering van vloeren voor kassa's en toonbanken van bedrijven en smalle verplichte doorgangen)

### Lineaire thermische uitzetting UNI EN ISO 10545/8

Met deze test wordt de waarde van de uitzettingscoëfficiënt van keramiektegels bij het variëren van de temperatuur vastgesteld. De lineaire thermische uitzettingscoëfficiënt wordt bepaald in het temperatuurbereik tussen de omgevingstemperatuur en 100°C.

### Weerstand tegen temperatuurswisselingen UNI EN ISO 10545/9

De weerstand tegen temperatuurswisselingen is de capaciteit van het oppervlak van het glazuur geen zichtbare

wijzigingen te ondergaan bij de "shock" als gevolg van temperatuurverschillen die worden veroorzaakt door achtereenvolgende cycli van onderdompeling in water op kamertemperatuur en verblijf in ovens met temperaturen hoger dan 105°. Er wordt aangegeven of de tegel hiertegen bestand is.

### Uitzetting door vocht UNI EN ISO 10545/10

De norm legt een methode vast voor het bepalen van de vochtexpansie van de keramische tegel door een verwarmde tegel in kokend water onder te dompelen en de proportionele wijzigingen van de lengte te meten. De meeste tegels hebben een verwaarloosbare vochtexpansie. Niettemin kan een vochtexpansie van meer dan 0,06% (0,6 mm/m) tot problemen leiden.

### Vorstbestandheid UNI EN ISO 10545/12

De vorstbestandheid is de eigenschap die tegels kunnen hebben in aanwezigheid van water bij temperaturen van onder de 0°C, nl. dat ze niet beschadigd raken door spanningen als gevolg van de toename van het volume van water bij bevriezing. Er wordt aangegeven of de tegel hiertegen bestand is.

### Chemische bestandheid UNI EN ISO 10545/13

De chemische bestandheid is de capaciteit van het glazuur om bij omgevingstemperatuur contact met chemische middelen (voor huishoudelijk gebruik, additieven voor zwembaden, zuren en base) te verdragen, zonder dat het uiterlijk daarvan verandert.

### Vaststelling van de weerstand tegen vlekken UNI EN ISO 10545/14

Methode die kan worden toegepast op alle gebruiksoppervlakken van keramiektegels om de weerstand tegen vlekken vast te stellen. Elk van de vlekveroorzakende middelen moet 24 uur blijven zitten op minstens 5 monsters, waarvan het gebruiksoppervlak vooraf gereinigd en gedroogd is. De vlekveroorzakende middelen worden verwijderd door opeenvolgende fasen waarbij verschillende reinigingsmiddelen en -procedures worden gebruikt.

**Klasse 5:** de vlek wordt verwijderd met warm water

**Klasse 4:** de vlek wordt verwijderd met een zwak in de handel verkrijgbaar reinigingsmiddel

**Klasse 3:** de vlek wordt verwijderd met een sterk in de handel verkrijgbaar reinigingsmiddel

**Klasse 2:** de vlek wordt verwijderd met oplosmiddelen, bijvoorbeeld aceton

### Ontdoan van lood en cadmium UNI EN ISO 10545/15

Deze test geeft een indicatie van de hoeveelheid lood en cadmium die uit keramiektegels vrijkomt. Bij deze test wordt het oppervlak van de tegel blootgesteld aan een azijnzuuroplossing.

### Brand weerstand

Het gedrag van een materiaal dat met zijn ontbinding bijdraagt aan de brand waaraan het wordt blootgesteld in bepaalde omstandigheden (UNI CEI EN ISO 13943 : 2004). De reactie op vuur van een materiaal wordt conventioneel uitgedrukt in klassen. Keramiek is ingedeeld in klasse A1 (onbrandbaar).

### Vindicatie voor de slipvastheid

→ DIN51130 "R"-indica-

tie voor de slipvastheid, afhankelijk van de hellingshoek waarmee een persoon die op een hellend vlak loop niet meer in staat is het evenwicht te bewaren.

→ Meting Van De Dynamische Wrijvingscoëfficiënt volgens de B.C.R.A. Rep. CEC/81-norm → Dynamische wrijvingscoëfficiënt volgens standaard ANSI A137.1-2012 (BOT3000)

→ Wrijvingscoëfficiënt volgens Britse norm BS 7976-2:2002 (CEN/TS 16165, Annex C) Pendulum Friction Test.

## Características técnicas

### Muestreo y criterios de aceptación

#### UNI EN ISO 10545-1

La Norma establece los criterios para la constitución de los lotes, para el muestreo, el control, la aceptación y rechazo de las baldosas de cerámica no instaladas. La Norma entrega un sistema de control basado en un muestreo doble que distingue un control por atributos (valores individuales) y un control sobre el valor medio (variables). El número de baldosas que se someten a prueba depende de la característica que se desea controlar.

### 10545-2 – Características dimensionales y de calidad de la superficie

UNI EN ISO 10545-2  
La Norma define los métodos para determinar las características dimensionales (longitud, anchura, grosor, rectitud de las aristas, ortogonalidad, planaridad) y la calidad de la superficie de la baldosa cerámica. Se usan calibradores pie de rey u otros instrumentos idóneos para mediciones lineales, se tienen que medir 10 baldosas enteras por cada tipo y se deben medir con la precisión de 0,1 mm cada lado de la pieza que se examina a la distancia de 5 mm de las esquinas.

### Absorción de agua

#### UNI EN ISO 10545/3

La absorción es la capacidad del producto cerámico de dejarse penetrar por el agua. Es fácil entender la importancia de dicho fenómeno para la determinación de las características y cualidades mecánicas del producto. Por esta razón las normativas europeas CEN subdividen las baldosas prensadas de acuerdo al porcentaje de absorción definiendo 5 grupos de pertenencia: ANEXOS G, H, J, K, L.

### Resistencia a la flexión

#### UNI EN ISO 10545/4

La resistencia a la flexión es un valor de carga límite aplicado sobre tres puntos que la baldosa puede soportar sin romperse. El valore es expresado en  $N/mm^2$  y la norma ISO 10545/4 establece los valores mínimos de aceptabilidad como sigue:  
Blb 35  
BlIa 30  
BlIb 18

### Coefficiente de restitución (COR)

UNI EN ISO 10545/5  
Es el método de ensayo que mide la resistencia al impacto de las baldosas a través del coeficiente de restitución mediante la caída de una bola de acero desde una altura predeterminada y la medición de la altura de rebote. El apéndice P de la norma 14411 muestra un valor indicativo de 0,55 por baldosas sometida a bajas tensiones sin tener que respetar límites.

### Resistencia a la abrasión profunda

UNI EN ISO 10545/6 (baldosas coloreadas en la masa o denominados ugl)  
Método aplicable sólo a las baldosas de cerámica no esmaltadas. El método de prueba y la expresión de los resultados son iguales a los indicados en las precedentes Normativas Europeas (EN 102). Ha sido aportada sólo una modificación en lo que respecta al material a emplear para la calibración del instrumento. El procedimiento de ajuste sigue siendo el mismo.

UNI EN ISO 10545/7 (baldosas esmaltadas o denominados gl)  
La resistencia a la abrasión es la capacidad de la superficie del esmalte de resistir a la acción del desgaste provocado por la circulación o por el roce

de cuerpos mecánicos (carretillas, etc.). Dicha acción de desgaste está conectada directamente al agente mecánico (suela de goma, suela de cuero, etc.); al material aportado (agua, arena, barro, etc.) y a la intensidad del tránsito. De acuerdo a la normativa, las baldosas son clasificadas según su destino de uso en las siguientes clases:  
**PEI I** Productos destinados a ambientes sometidos a un tránsito ligero y son suciedad abrasiva; por ejemplo baños, dormitorios  
**PEI II** Productos destinados a ambientes sometidos a un tránsito medio y a una acción abrasiva medio-baja; por ejemplo estudios  
**PEI III** Productos destinados a ambientes sometidos a un tránsito medio fuerte con acción abrasiva media; por ejemplo entradas, cocinas de casas privadas  
**PEI IV** Productos destinados a ambientes sometidos a un tránsito intenso; por ej. restaurantes, oficinas, negocios, oficinas públicas (excluyendo los pavimentos subyacentes las cajas y mostradores de ejercicios públicos y pasos restringidos obligados)  
**PEI V** Productos destinados a ambientes sometidos a un tránsito particularmente intenso.

### Coefficiente de dilatación térmica lineal

UNI EN ISO 10545/8  
Es el método de ensayo del valor del coeficiente de dilatación de las baldosas de cerámica con temperatura variable. El coeficiente de dilatación térmica lineal se determina en el intervalo de temperatura entre la del ambiente y 100°C.

### Resistencia al choque térmico

UNI EN ISO 10545/9  
La resistencia al choque térmico es la capacidad de la superficie del esmalte de no sufrir alteraciones visibles

producto de las oscilaciones de temperatura inducidas con ciclos sucesivos de inmersión en agua a temperatura ambiente y posicionamiento en estufa a temperaturas superiores a 105°C. Cuando la baldosa es resistente es indicado.

### Expansión por humedad

UNI EN ISO 10545/10  
La norma recoge el método de ensayo para determinar la expansión por humedad de la baldosa de cerámica al sumergir una baldosa recocida en agua hirviendo, y midiendo el cambio relativo de su longitud. La mayoría de las baldosas cerámicas tienen una expansión por humedad despreciable, no obstante una expansión por humedad que supere el 0,06% (0,6mm/m) puede originar problemas.

### Resistencia a la helada

UNI EN ISO 10545/12  
La resistencia a la helada es la característica que pueden presentar las baldosas en presencia de agua a temperaturas inferiores a los 0°C de no sufrir daños por las tensiones producidas por el aumento de volumen del agua producto del congelamiento. Es indicado cuando la baldosa es resistente.

### Resistencia química

UNI EN ISO 10545/13  
La resistencia al ataque químico es la capacidad del esmalte de tolerar a temperatura ambiente el contacto con sustancias químicas (de uso doméstico, manchadores, aditivos para piscinas, ácidos y bases) sin sufrir alteraciones de aspecto.

### Determinación de la resistencia a las manchas

UNI EN ISO 10545/14

Método aplicable a todas las superficies de ejercicio de las baldosas de cerámica para determinar la resistencia a las manchas. Cada uno de los agentes manchadores tiene que ser mantenido por 24 horas sobre por lo menos 5 muestras de prueba cuya superficie ha sido previamente limpiada y secada. La eliminación de los agentes manchadores ocurre por fases sucesivas empleando diversos agentes y procedimientos de limpieza.  
**Clase 5:** la mancha se quita con agua caliente  
**Clase 4:** la mancha se quita con un agente limpiador comercial débil  
**Clase 3:** la mancha se quita con un agente limpiador comercial fuerte  
**Clase 2:** la mancha se quita con solventes como por ejemplo la acetona.

### Cesión de plomo y cadmio

UNI EN ISO 10545/15  
Es el método de ensayo que indica la cantidad de plomo y cadmio desprendidos del esmalte de las baldosas cerámicas. La prueba se realiza mediante la exposición de la superficie esmaltada de la baldosa a una disolución de ácido acético.

### Resistencia al fuego

El comportamiento de un material que contribuye con su propia descomposición frente al fuego al que está sometido en condiciones determinadas. (UNI CEI EN ISO 13943 : 2004). La reacción al fuego de un material se expresa convencionalmente en clases. La cerámica está clasificada en clase A1 (productos incombustibles).











### Determinación de las características antideslizamiento

→ Índice DIN51130 "R" de resistencia al deslizamiento, en función del ángulo de inclinación con el cual una persona

que camina sobre el plano inclinado deja de ser capaz de mantener el equilibrio.





→ Coeficiente de rozamiento dinámico de acuerdo a la norma B.C.R.A. Rep. CEC/81  
→ Coeficiente de rozamiento dinámico de acuerdo a la norma ANSI A137.1-2012 (BOT3000)  
→ Coeficiente de rozamiento de acuerdo a la norma BS 7976-2:2002 (CEN/TS 16165, Annex C) Pendulum Friction Test.

## Gres Fine Porcellanato – EN 14411 ISO 13006 Gruppo Bla Annex G

	Regulation	Required standards	Artech	Avantgarde	Baita	Block
 <b>Dimensioni/Sizes/Dimensions/ Abmessungen/Afmetingen/ Dimensiones</b>	UNI EN ISO 10545/2	Non rettificato Not rectified Rettificato* Rectified*				
		→ Lunghezza e larghezza/Length and width/Longueur et largeur/Länge und Breite/Lengte en breedte/Longitud y anchura $\pm 0,6\%$ max 2mm $\pm 0,3\%$ max 1mm				
		→ Spessore/Thickness/Epaisseur/ Stärke/Dikte/Grosor $\pm 5\%$ max 0,5mm $\pm 5\%$ max 0,5mm				
		→ Rettilinearità spigoli/Linearity/Rectitude des arêtes/ Kantengeradheit/Rechtheid kanten/Rectitud de los lados $\pm 0,5\%$ max 1,5mm $\pm 0,3\%$ max 0,8mm	Conforme Compliant	Conforme Compliant	Conforme Compliant	Conforme Compliant
		→ * Ortogonalità/Wedging/Orthogonalité/ Rechtwinkligkei/Haaksheid hoeken/Ortogonalidad $\pm 0,5\%$ max 2mm $\pm 0,3\%$ max 1,5mm				
		→ Planarità/Warpage/Planéité/Ebenflächigkeit/ Vlakheid/Planitud $\pm 0,5\%$ max 2mm $\pm 0,4\%$ max 1,8mm				
 <b>Assorbimento acqua/Water absorption/Absorption d'eau/ Wasseraufnahme/Waterabsorptie/ Absorción de agua</b>	UNI EN ISO 10545/3	$\leq 0,5\%$	0,2%	0,2%	0,2%	0,2%
 <b>Resistenza alla flessione/Flexual Strenght/Résistance à la flexion/ Biegefestigkeit/Buigvastheid/ Resistencia a la flexión</b>	UNI EN ISO 10545/4	$\geq 35\text{ N/mm}^2$  $S \geq 1300\text{ N}$ (thickness $\geq 7,5\text{ mm}$ )	Conforme Compliant	Conforme Compliant	Conforme Compliant	Conforme Compliant
 <b>Coefficiente di restituzione (COR)/ Coefficient of restitution (COR)/ Coefficient de restitution (COR)/ Schlagfestigkeit (COR)/ Restitutiecoëfficiënt (COR)/ Coeficiente de restitución (COR)</b>	UNI EN ISO 10545/5	Valore consigliato $\geq 0,55$ / Recommended value $\geq 0,55$ / Valeur recommandée $\geq 0,55$ / Empfohlener Wert $\geq 0,55$ / Aanbevolen waarde $\geq 0,55$ / Ralor recomendado $\geq 0,55$	Conforme Compliant	Conforme Compliant	Conforme Compliant	Conforme Compliant
 <b>Resistenza all'abrasione profonda/ Deep abrasion resistance/ Resistance à l'abrasion/ Widerstand gegen Tiefenverschleiß/ Weerstand tegen afschuren/ Resistencia a la abrasión profunda</b>	UNI EN ISO 10545/6	$\leq 175\text{ mm}^3$	Conforme Compliant	Conforme Compliant	Conforme Compliant	Conforme Compliant
 <b>Resistenza all'abrasione/ Abrasion resistance/ Résistance à l'abrasion/ Abriebbeständigkeit/ Weerstand tegen afschuring/ Resistencia a la abrasión</b>	UNI EN ISO 10545/7	PEI Solo per piastrelle smaltate / Only for glazed tiles				
 <b>Coefficiente di dilatazione termica lineare/Coefficient of thermal linear expansion/Coefficient de dilatation thermique lineare/ Wärmeausdehnungskoeffizient/ Lineaire thermische uitzetting/ Coeficiente de dilatación termica lineare</b>	UNI EN ISO 10545/8	Metodo di prova disponibile/Tests method available/ Methode d'essai disponible/Verfügbares/Prüfverfahren/ Testmethode beschikbaar/Método de prueba disponible	$\leq 7 \cdot 10^{-6}\text{ }^{\circ}\text{C}^{-1}$	$\leq 7 \cdot 10^{-6}\text{ }^{\circ}\text{C}^{-1}$	$\leq 7 \cdot 10^{-6}\text{ }^{\circ}\text{C}^{-1}$	$\leq 7 \cdot 10^{-6}\text{ }^{\circ}\text{C}^{-1}$
 <b>Resistenza agli sbalzi termici/ Thermal shock resistance/ Resistance aux écarts de temperature/ Temperaturwechselbeständigkeit/ Temperatuurswisselingen/ Resistencia al choque térmico</b>	UNI EN ISO 10545/9	Nessun campione deve presentare difetti visibili/ No sample must show visible defects/ Aucun échantillon ne doit présenter des défauts visibles/ Kein Exemplar darf sichtbare Schäden aufweisen/ Geen enkel monster mag zichtbare gebreken vertonen/ Ninguna muestra debe presentar defectos visibles	Conforme Compliant	Conforme Compliant	Conforme Compliant	Conforme Compliant
 <b>Dilatazione all'umidità/Moisture expansion/Dilatation à l'humidité/ Feuchtigkeitsausdehnung/ Uitzetting door vocht/Dilatación por la humedad</b>	UNI EN ISO 10545/10	Metodo di prova disponibile/Tests method available/ Methode d'essai disponible/Verfügbares/Prüfverfahren/ Testmethode beschikbaar/Método de prueba disponible	$\leq 0,01\%$ (0,1 mm/m)	$\leq 0,01\%$ (0,1 mm/m)	$\leq 0,01\%$ (0,1 mm/m)	$\leq 0,01\%$ (0,1 mm/m)
 <b>Resistenza al fuoco/ Fire resistance/ Résistance au feu/ Brandverhalten/ Brand weerstand/ Resistencia al fuego</b>	UNI EN ISO 13501-1	Dichiarare un valore / Declare a value Classe A1 oppure A <sub>1s</sub> / Class A1 or A <sub>1s</sub>	A <sub>1s</sub>	A <sub>1s</sub>	A <sub>1s</sub>	A <sub>1s</sub>
 <b>Resistenza al gelo/Frost resistance/Résistance au gel/Frostbeständigkeit/ Vorstbestandheid/ Resistencia a la helada</b>	UNI EN ISO 10545/12	Resistenti/Resistant/Resistants/ Widerstandsfähig/ Weerbaarstig/Resistentes	Conforme Compliant	Conforme Compliant	Conforme Compliant	Conforme Compliant











\* Per piastrelle rettangolari, che abbiano il lato maggiore  $L \geq 60\text{ cm}$ , e rapporto tra i lati  $\geq 3$ , la misurazione della ortogonalità deve venire condotta solo sul lato corto.  
For oblong tiles with  $L \geq 60\text{ cm}$  and ratio length/width  $L/W \geq 3$ , measurement of rectangularity only on short edges

## Gres Fine Porcellanato – EN 14411 ISO 13006 Gruppo Bla Annex G

	Regulation	Required standards	Artech	Avantgarde	Baita	Block	
 <b>Resistenza all'attacco chimico/</b> <b>Chemical resistance/Resistance</b> <b>à l'attaque chimique/Beständigkeit</b> <b>gegen Chemikalien/Chemische</b> <b>bestandheid/Resistencia al ataque</b> <b>químico</b>	UNI EN ISO 10545/13						
		Resistenza ai prodotti chimici di uso domestico ed agli additivi per piscina / Resistance to household chemicals and swimming pool salts	Classe minima B (GB per piastrelle smaltate) / Minimum class B (GB for glazed tiles)	A	A	A	A
		Resistenza a basse concentrazioni di acidi e alcali / Resistance to low concentrations of acids and alkalis	Classe minima B (UB per piastrelle non smaltate) / Minimum class B (UB for unglazed tiles)	LA	LA	LA	LA
		Resistenza ad alte concentrazioni di acidi e alcali / Resistance to high concentrations of acids and alkalis	Dichiarare una classe / Declare a class Metodo di prova disponibile / Tests method available	HA	HA	HA	HA
 <b>Resistenza alle macchie/Stain</b> <b>resistance/Insensibilité aux</b> <b>taches/Beständigkeit gegen</b> <b>Fleckenbildner/Substanzen/</b> <b>Weerstand tegen vlekken/</b> <b>Resistencia a las manchas</b>	UNI EN ISO 10545/14	UGL Dichiarare un valore / UGL Declare a value  GL ≥ 3	Classe 5 Class 5	Classe 5 Class 5	Classe 5 Class 5	Classe 5 Class 5	
 <b>Cessione di piombo e cadmio/</b> <b>Lead and cadmium discharge/</b> <b>Perte de plomb et cadmium/</b> <b>Abgabe von Blei und Cadmium/</b> <b>Ontaan van lood en cadmium/</b> <b>Cesión de plomo y cadmio</b>	UNI EN ISO 10545/15	Valore dichiarato per piastrelle GL / Declared value for GL tiles					
 <b>Indicazione di resistenza allo</b> <b>scivolamento/Assessment</b> <b>of slip resistance/Indication</b> <b>de la résistance au glissement/</b> <b>Bestimmung der Trittsicherheit/</b> <b>Indicatie voor de slipvastheid/</b> <b>Indicación de resistencia al</b> <b>deslizamiento</b>	DIN 51130	Dichiarare un valore (R) / Declare a value (R)		R9	R10	R10 Matt R11 OUT2.0	
	DIN 51097	Dichiarare un valore (A+B+C) / Declare a value (A+B+C)				A+B Matt A+B+C OUT2.0	
	BS 7976-2:2002 (CEN/TS 16165, Annex C) Pendulum Friction Test	Dichiarare un valore / Declare a value			≥ 36 Wet	≥ 36 Wet Matt	
 <b>Coefficiente di attrito dinamico/</b> <b>Measurement of dynamic</b> <b>coefficient of friction/</b> <b>Mesure du coefficient de</b> <b>frottement dynamique/</b> <b>Messung des dynamischen</b> <b>Reibungskoeffizienten/</b> <b>Meting van de dynamische</b> <b>wrijvingscoefficient/Coefficiente de</b> <b>rozamiento dinámico</b>	B.C.R.A. Rep. CEC/81	Asciutto > 0,40 / Bagnato > 0,40	Asciutto > 0,40 / Bagnato > 0,40	Asciutto > 0,40 / Bagnato > 0,40	Asciutto > 0,40 / Bagnato > 0,40	Asciutto > 0,40 / Bagnato > 0,40 Matt/Soft	
	ANSI A137.1- 2012 (BOT3000)	> 0,42 Wet	> 0,42 Wet	> 0,42 Wet	> 0,42 Wet	> 0,42 Wet Matt/Soft	





I valori indicati nella tabella si riferiscono a superfici naturali (non Lappato)/The values in the table refer to natural (not Lappato - honed) surfaces /Les valeurs du tableau se rapportent à des surfaces naturelle (non Lappato - adoucis)/Die in der Tabelle angeführten Werte beziehen sich auf naturbelassene (nicht Lappato - geläppte) Oberflächen/De waarden in de tabel hebben betrekking op natuurlijke oppervlakken (niet Lappato - Zijdeglans)/Los valores indicados en la tabla se refieren a las superficies naturales (no Lappato - semipulido)

## Gres Fine Porcellanato – EN 14411 ISO 13006 Gruppo Bla Annex G

	Regulation	Required standards	Blue Emotion	Bluetech	Bricklane	Chevron
	Dimensioni/Sizes/Dimensions/ Abmessungen/Afmetingen/ Dimensiones	UNI EN ISO 10545/2	Non rettificato Not rectified	Rettificato* Rectified*		
		→ Lunghezza e larghezza/Length and width/Longueur et largeur/Länge und Breite/Lengte en breedte/Longitud y anchura	± 0,6 % max 2mm	± 0,3 % max 1mm		
	* According to ISO 13006.	→ Spessore/Thickness/Epaisseur/ Stärke/Dicke/Grosor	± 5 % max 0,5mm	± 5 % max 0,5mm		
		→ Rettilinearità spigoli/Linearity/Rectitude des arêtes/ Kantengeradheit/Rechtheid kanten/Rectitud de los lados	± 0,5 % max 1,5mm	± 0,3 % max 0,8mm	Conforme Compliant	Conforme Compliant
		→ * Ortogonalità/Wedging/Orthogonalité/ Rechtwinkligkei/Haaksheid hoeken/Ortogonalidad	± 0,5 % max 2mm	± 0,3 % max 1,5mm		
		→ Planarità/Warpage/Planéité/Ebenflächigkeit/ Vlakheid/Planitud	± 0,5 % max 2mm	± 0,4 % max 1,8mm		
	Assorbimento acqua/Water absorption/Absorption d'eau/ Wasseraufnahme/Waterabsorptie/ Absorción de agua	UNI EN ISO 10545/3	≤ 0,5 %	0,2%	0,2%	0,2%
	Resistenza alla flessione/Flexual Strenght/Résistance à la flexion/ Biegefestigkeit/Buigvastheid/ Resistencia a la flexión	UNI EN ISO 10545/4	≥ 35 N/mm <sup>2</sup>  S ≥ 1300 N (thickness ≥ 7,5 mm)	Conforme Compliant	Conforme Compliant	Conforme Compliant
	Coefficiente di restituzione (COR)/ Coefficient of restitution (COR)/ Coefficient de restitution (COR)/ Schlagfestigkeit (COR)/ Restitutiecoëfficiënt (COR)/ Coeficiente de restitución (COR)	UNI EN ISO 10545/5	Valore consigliato ≥ 0,55/ Recommended value ≥ 0,55/ Valeur recommandée ≥ 0,55/ Empfohlener Wert ≥ 0,55/ Aanbevolen waarde ≥ 0,55/ Ralor recomendado ≥ 0,55	Conforme Compliant	Conforme Compliant	Conforme Compliant
	Resistenza all'abrasione profonda/ Deep abrasion resistance/ Resistance à l'abrasion/ Widerstand gegen Tiefenverschleiß/ Weerstand tegen afschuren/ Resistencia a la abrasión profunda	UNI EN ISO 10545/6	≤ 175 mm <sup>3</sup>	Conforme Compliant	Conforme Compliant	Conforme Compliant
	Resistenza all'abrasione/ Abrasion resistance/ Résistance à l'abrasion/ Abriebbeständigkeit/ Weerstand tegen afschuring/ Resistencia a la abrasión	UNI EN ISO 10545/7	PEI Solo per piastrelle smaltate / Only for glazed tiles			
	Coefficiente di dilatazione termica lineare/Coefficient of thermal linear expansion/Coefficient de dilatation thermique lineair/Lineaire Wärmeausdehnungskoeffizient/ Lineaire thermische uitzetting/ Coeficiente de dilatación termica lineair	UNI EN ISO 10545/8	Metodo di prova disponibile/Tests method available/ Methode d'essai disponible/Verfügbares/Prüfverfahren/ Testmethode beschikbaar/Método de prueba disponible	≤ 7 10 <sup>-6</sup> •C <sup>-1</sup>	≤ 7 10 <sup>-6</sup> •C <sup>-1</sup>	≤ 7 10 <sup>-6</sup> •C <sup>-1</sup>
	Resistenza agli sbalzi termici/ Thermal shock resistance/ Resistance aux écarts de temperature/ Temperaturwechselbeständigkeit/ Temperatuurswisselingen/ Resistencia al choque térmico	UNI EN ISO 10545/9	Nessun campione deve presentare difetti visibili/ No sample must show visible defects/ Aucun échantillon ne doit présenter des défauts visibles/ Kein Exemplar darf sichtbare Schäden aufweisen/ Geen enkel monster mag zichtbare gebreken vertonen/ Ninguna muestra debe presentar defectos visibles	Conforme Compliant	Conforme Compliant	Conforme Compliant
	Dilatazione all'umidità/Moisture expansion/Dilatation à l'humidité/ Feuchtigkeitsausdehnung/ Uitzetting door vocht/Dilatación por la humedad	UNI EN ISO 10545/10	Metodo di prova disponibile/Tests method available/ Methode d'essai disponible/Verfügbares/Prüfverfahren/ Testmethode beschikbaar/Método de prueba disponible	≤ 0,01 % (0,1 mm/m)	≤ 0,01 % (0,1 mm/m)	≤ 0,01 % (0,1 mm/m)
	Resistenza al fuoco/ Fire resistance/ Résistance au feu/ Brandverhalten/ Brand weerstand/ Resistencia al fuego	UNI EN ISO 13501-1	Dichiarare un valore / Declare a value  Classe A1 oppure A <sub>1s</sub> / Class A1 or A <sub>1s</sub>	A <sub>1s</sub>	A <sub>1s</sub>	A <sub>1s</sub>
	Resistenza al gelo/Frost resistance/Résistance au gel/Frostbeständigkeit/ Vorstandigheid/ Resistencia a la helada	UNI EN ISO 10545/12	Resistenti/Resistant/Resistants/ Widerstandsfähig/ Weerbaarstig/Resistentes	Conforme Compliant	Conforme Compliant	Conforme Compliant

\* Per piastrelle rettangolari, che abbiano il lato maggiore L ≥ 60 cm, e rapporto tra i lati ≥ 3, la misurazione della ortogonalità deve venire condotta solo sul lato corto.  
For oblong tiles with L ≥ 60 cm and ratio length/width L/W ≥ 3, measurement of rectangularity only on short edges











## Gres Fine Porcellanato – EN 14411 ISO 13006 Gruppo Bla Annex G

	Regulation	Required standards	Blue Emotion	Bluetech	Bricklane	Chevron	
 <b>Resistenza all'attacco chimico/ Chemical resistance/Resistance à l'attaque chimique/Beständigkeit gegen Chemikalien/Chemische bestandheid/Resistencia al ataque químico</b>	UNI EN ISO 10545/13						
		Resistenza ai prodotti chimici di uso domestico ed agli additivi per piscina / Resistance to household chemicals and swimming pool salts	Classe minima B (GB per piastrelle smaltate) / Minimum class B (GB for glazed tiles)	A	A	A	A
		Resistenza a basse concentrazioni di acidi e alcali / Resistance to low concentrations of acids and alkalis	Classe minima B (UB per piastrelle non smaltate) / Minimum class B (UB for unglazed tiles)	LA	LA	LA	LA
		Resistenza ad alte concentrazioni di acidi e alcali / Resistance to high concentrations of acids and alkalis	Dichiarare una classe / Declare a class Metodo di prova disponibile / Tests method available	HA	HA	HA	HA
 <b>Resistenza alle macchie/Stain resistance/Insensibilité aux taches/Beständigkeit gegen Fleckenbildner/Substanzen/Weerstand tegen vlekken/Resistencia a las manchas</b>	UNI EN ISO 10545/14	UGL Dichiarare un valore / UGL Declare a value	Classe 5 Class 5	Classe 5 Class 5	Classe 5 Class 5	Classe 5 Class 5	
		GL ≥ 3					
 <b>Cessione di piombo e cadmio/ Lead and cadmium discharge/ Perte de plomb et cadmium/ Abgabe von Blei und Cadmium/ Ontdaan van lood en cadmium/ Cesión de plomo y cadmio</b>	UNI EN ISO 10545/15	Valore dichiarato per piastrelle GL / Declared value for GL tiles					
 <b>Indicazione di resistenza allo scivolamento/Assessment of slip resistance/Indication de la résistance au glissement/ Bestimmung der Trittsicherheit/ Indicatie voor de slipvastheid/ Indicación de resistencia al deslizamiento</b>	DIN 51130	Dichiarare un valore (R) / Declare a value (R)	R9 Scié R10 Flammé R11 OUT 2.0	R9 Vintage Charbon R10 Design Vintage Plain R11 OUT 2.0	R9	R10	
	DIN 51097	Dichiarare un valore (A+B+C) / Declare a value (A+B+C)	A+B Flammé A+B+C OUT 2.0	A+B Vintage Plain A+B+C Design			
	BS 7976-2:2002 (CEN/TS 16165, Annex C) Pendulum Friction Test	Dichiarare un valore / Declare a value					
 <b>Coefficiente di attrito dinamico/ Measurement of dynamic coefficient of friction/ Mesure du coefficient de frottement dynamique/ Messung des dynamischen Reibungskoeffizienten/ Meting van de dynamische wrijvingscoefficient/Coefficiente de rozamiento dinámico</b>	B.C.R.A. Rep. CEC/31	Asciutto > 0,40 / Bagnato > 0,40	Asciutto > 0,40 / Bagnato > 0,40	Asciutto > 0,40 / Bagnato > 0,40	Asciutto > 0,40 / Bagnato > 0,40	Asciutto > 0,40 / Bagnato > 0,40	
	ANSI A137.1-2012 (BOT3000)	> 0,42 Wet	> 0,42 Wet	> 0,42 Wet	> 0,42 Wet	> 0,42 Wet	

I valori indicati nella tabella si riferiscono a superfici naturali (non Lappato)/The values in the table refer to natural (not Lappato - honed) surfaces /Les valeurs du tableau se rapportent à des surfaces naturelle (non Lappato - adoucis)/Die in der Tabelle angeführten Werte beziehen sich auf naturbelassene (nicht Lappato - geläppte) Oberflächen/ De waarden in de tabel hebben betrekking op natuurlijke oppervlakken (niet Lappato - Zijdeglans)/Los valores indicados en la tabla se refieren a las superficies naturales (no Lappato - semipulido)







## Gres Fine Porcellanato – EN 14411 ISO 13006 Gruppo Bla Annex G

	Regulation	Required standards	Creos	Cromie	Deck	Design Industry	
	Dimensioni/Sizes/Dimensions/ Abmessungen/Afmetingen/ Dimensiones	UNI EN ISO 10545/2	Non rettificato Not rectified	Rettificato * Rectified *			
		→ Lunghezza e larghezza/Length and width/Longueur et largeur/Länge und Breite/Lengte en breedte/Longitud y anchura	± 0,6 % max 2mm	± 0,3 % max 1mm			
	* According to ISO 13006.	→ Spessore/Thickness/Epaisseur/ Stärke/Dicke/Grosor	± 5 % max 0,5mm	± 5 % max 0,5mm			
		→ Rettilinearità spigoli/Linearity/Rectitude des arêtes/ Kantengeradheit/Rechtheid kanten/Rectitud de los lados	± 0,5 % max 1,5mm	± 0,3 % max 0,8mm	Conforme Compliant	Conforme Compliant	
		→ * Ortogonalità/Wedging/Orthogonalité/ Rechtwinkligkei/Haaksheid hoeken/Ortogonalidad	± 0,5 % max 2mm	± 0,3 % max 1,5mm			
		→ Planarità/Warpage/Planité/Ebenflächigkeit/ Vlakheid/Planitud	± 0,5 % max 2mm	± 0,4 % max 1,8mm			
	Assorbimento acqua/Water absorption/Absorption d'eau/ Wasseraufnahme/Waterabsorptie/ Absorción de agua	UNI EN ISO 10545/3	≤ 0,5 %	0,2%	0,2%	0,2%	
	Resistenza alla flessione/Flexual Strenght/Résistance à la flexion/ Biegefestigkeit/Buigvastheid/ Resistencia a la flexión	UNI EN ISO 10545/4	≥ 35 N/mm <sup>2</sup>  S ≥ 1300 N (thickness ≥ 7,5 mm)	Conforme Compliant	Conforme Compliant	Conforme Compliant	
	Coefficiente di restituzione (COR)/ Coefficient of restitution (COR)/ Coefficient de restitution (COR)/ Schlagfestigkeit (COR)/ Restitutiecoëfficiënt (COR)/ Coeficiente de restitución (COR)	UNI EN ISO 10545/5	Valore consigliato ≥ 0,55/ Recommended value ≥ 0,55/ Valeur recommandée ≥ 0,55/ Empfohlener Wert ≥ 0,55/ Aanbevolen waarde ≥ 0,55/ Ralor recomendado ≥ 0,55	Conforme Compliant	Conforme Compliant	Conforme Compliant	
	Resistenza all'abrasione profonda/ Deep abrasion resistance/ Resistance à l'abrasion/ Widerstand gegen Tiefenverschleiß/ Weerstand tegen afschuren/ Resistencia a la abrasión profunda	UNI EN ISO 10545/6	≤ 175 mm <sup>3</sup>	Conforme Compliant	Conforme Compliant	Conforme Compliant	
	Resistenza all'abrasione/ Abrasion resistance/ Résistance à l'abrasion/ Abriebbeständigkeit/ Weerstand tegen afschuring/ Resistencia a la abrasión	UNI EN ISO 10545/7	PEI Solo per piastrelle smaltate / Only for glazed tiles				
	Coefficiente di dilatazione termica lineare/Coefficient of thermal linear expansion/Coefficient de dilatation thermique linear/Lineare Wärmeausdehnungskoeffizient/ Lineaire thermische uitzetting/ Coeficiente de dilatación termica linear	UNI EN ISO 10545/8	Metodo di prova disponibile/Tests method available/ Methode d'essai disponible/Verfügbares/Prüfverfahren/ Testmethode beschikbaar/Método de prueba disponible	≤ 7 10 <sup>-6</sup> •C <sup>-1</sup>	≤ 7 10 <sup>-6</sup> •C <sup>-1</sup>	≤ 7 10 <sup>-6</sup> •C <sup>-1</sup>	≤ 7 10 <sup>-6</sup> •C <sup>-1</sup>
	Resistenza agli sbalzi termici/ Thermal shock resistance/ Resistance aux ecarts de temperature/ Temperaturwechselbeständigkeit/ Temperatuurswisselingen/ Resistencia al choque térmico	UNI EN ISO 10545/9	Nessun campione deve presentare difetti visibili/ No sample must show visible defects/ Aucun échantillon ne doit présenter des défauts visibles/ Kein Exemplar darf sichtbare Schäden aufweisen/ Geen enkel monster mag zichtbare gebreken vertonen/ Ninguna muestra debe presentar defectos visibles	Conforme Compliant	Conforme Compliant	Conforme Compliant	Conforme Compliant
	Dilatazione all'umidità/Moisture expansion/Dilatation à l'humidité/ Feuchtigkeitsausdehnung/ Uitzetting door vocht/Dilatación por la humedad	UNI EN ISO 10545/10	Metodo di prova disponibile/Tests method available/ Methode d'essai disponible/Verfügbares/Prüfverfahren/ Testmethode beschikbaar/Método de prueba disponible	≤ 0,01 % (0,1 mm/m)	≤ 0,01 % (0,1 mm/m)	≤ 0,01 % (0,1 mm/m)	≤ 0,01 % (0,1 mm/m)
	Resistenza al fuoco/ Fire resistance/ Résistance au feu/ Brandverhalten/ Brand weerstand/ Resistencia al fuego	UNI EN ISO 13501-1	Dichiarare un valore / Declare a value  Classe A1 oppure A <sub>1s</sub> / Class A1 or A <sub>1s</sub>	A <sub>1s</sub>	A <sub>1s</sub>	A <sub>1s</sub>	A <sub>1s</sub>
	Resistenza al gelo/Frost resistance/Résistance au gel/Frostbeständigkeit/ Vorstandigheid/ Resistencia a la helada	UNI EN ISO 10545/12	Resistenti/Resistant/Resistants/ Widerstandsfähig/ Weerbaarstig/Resistentes	Conforme Compliant	Conforme Compliant	Conforme Compliant	Conforme Compliant











\* Per piastrelle rettangolari, che abbiano il lato maggiore L ≥ 60 cm, e rapporto tra i lati ≥ 3, la misurazione della ortogonalità deve venire condotta solo sul lato corto.  
For oblong tiles with L ≥ 60 cm and ratio length/width L/W ≥ 3, measurement of rectangularity only on short edges

## Gres Fine Porcellanato – EN 14411 ISO 13006 Gruppo Bla Annex G

	Regulation	Required standards	Creos	Cromie	Deck	Design Industry	
 <b>Resistenza all'attacco chimico/</b> <b>Chemical resistance/Resistance</b> <b>à l'attaque chimique/Beständigkeit</b> <b>gegen Chemikalien/Chemische</b> <b>bestandheid/Resistencia al ataque</b> <b>químico</b>	UNI EN ISO 10545/13						
		Resistenza ai prodotti chimici di uso domestico ed agli additivi per piscina / Resistance to household chemicals and swimming pool salts	Classe minima B (GB per piastrelle smaltate) / Minimum class B (GB for glazed tiles)	A	A	A	A
		Resistenza a basse concentrazioni di acidi e alcali / Resistance to low concentrations of acids and alkalis	Classe minima B (UB per piastrelle non smaltate) / Minimum class B (UB for unglazed tiles)	LA	LA	LA	LA
		Resistenza ad alte concentrazioni di acidi e alcali / Resistance to high concentrations of acids and alkalis	Dichiarare una classe / Declare a class Metodo di prova disponibile / Tests method available	HA	HA	HA	HA
 <b>Resistenza alle macchie/Stain</b> <b>resistance/Insensibilité aux</b> <b>taches/Beständigkeit gegen</b> <b>Fleckenbildner/Substanzen/</b> <b>Weerstand tegen vlekken/</b> <b>Resistencia a las manchas</b>	UNI EN ISO 10545/14	UGL Dichiarare un valore / UGL Declare a value  GL ≥ 3	Classe 5 Class 5	Classe 5 Class 5	Classe 5 Class 5	Classe 5 Class 5	
 <b>Cessione di piombo e cadmio/</b> <b>Lead and cadmium discharge/</b> <b>Perte de plomb et cadmium/</b> <b>Abgabe von Blei und Cadmium/</b> <b>Ontdaan van lood en cadmium/</b> <b>Cesión de plomo y cadmio</b>	UNI EN ISO 10545/15	Valore dichiarato per piastrelle GL / Declared value for GL tiles					
 <b>Indicazione di resistenza allo</b> <b>scivolamento/Assessment</b> <b>of slip resistance/Indication</b> <b>de la résistance au glissement/</b> <b>Bestimmung der Trittsicherheit/</b> <b>Indicatie voor de slipvastheid/</b> <b>Indicación de resistencia al</b> <b>deslizamiento</b>	DIN 51130	Dichiarare un valore (R) / Declare a value (R)	R10 Matt	R9	R10	R9 R10 Oxide Light Strutt.	
	DIN 51097	Dichiarare un valore (A+B+C) / Declare a value (A+B+C)			A+B	A+B Oxide Light Strutt.	
	BS 7976-2:2002 (CEN/TS 16165, Annex C) Pendulum Friction Test	Dichiarare un valore / Declare a value		≥ 36 Wet			
 <b>Coefficiente di attrito dinamico/</b> <b>Measurement of dynamic</b> <b>coefficient of friction/</b> <b>Mesure du coefficient de</b> <b>frottement dynamique/</b> <b>Messung des dynamischen</b> <b>Reibungskoeffizienten/</b> <b>Meting van de dynamische</b> <b>wrijvingscoefficient/Coefficiente de</b> <b>rozamiento dinámico</b>	B.C.R.A. Rep. CEC/31	Asciutto > 0,40 / Bagnato > 0,40	Asciutto > 0,40 / Bagnato > 0,40 Matt/Soft	Asciutto > 0,40 / Bagnato > 0,40	Asciutto > 0,40 / Bagnato > 0,40	Asciutto > 0,40 / Bagnato > 0,40	
	ANSI A137.1- 2012 (BOT3000)	> 0,42 Wet	> 0,42 Wet Matt/Soft	> 0,42 Wet	> 0,42 Wet	> 0,42 Wet	





I valori indicati nella tabella si riferiscono a superfici naturali (non Lappato)/The values in the table refer to natural (not Lappato - honed) surfaces /Les valeurs du tableau se rapportent à des surfaces naturelle (non Lappato - adoucis)/Die in der Tabelle angeführten Werte beziehen sich auf naturbelassene (nicht Lappato - geläppte) Oberflächen/De waarden in de tabel hebben betrekking op natuurlijke oppervlakken (niet Lappato - Zijdeglans)/Los valores indicados en la tabla se refieren a las superficies naturales (no Lappato - semipulido)

## Gres Fine Porcellanato – EN 14411 ISO 13006 Gruppo Bla Annex G

	Regulation	Required standards	Epoque	Essence	Flake	Foil	
	Dimensioni/Sizes/Dimensions/ Abmessungen/Afmetingen/ Dimensiones	UNI EN ISO 10545/2	Non rettificato Not rectified	Rettificato * Rectified *			
		→ Lunghezza e larghezza/Length and width/Longueur et largeur/Länge und Breite/Lengte en breedte/ Longitud y anchura	± 0,6 % max 2mm	± 0,3 % max 1mm			
	* According to ISO 13006.	→ Spessore/Thickness/Epaisseur/ Stärke/Dicke/Grosor	± 5 % max 0,5mm	± 5 % max 0,5mm			
		→ Rettilinearità spigoli/Linearity/Rectitude des arêtes/ Kantengeradheit/Rechtheid kanten/Rectitud de los lados	± 0,5 % max 1,5mm	± 0,3 % max 0,8mm	Conforme Compliant	Conforme Compliant	
		→ * Ortogonalità/Wedging/Orthogonalité/ Rechtwinkligkei/Haaksheid hoeken/Ortogonalidad	± 0,5 % max 2mm	± 0,3 % max 1,5mm			
		→ Planarità/Warpage/Planité/Ebenflächigkeit/ Vlakheid/Planitud	± 0,5 % max 2mm	± 0,4 % max 1,8mm			
	Assorbimento acqua/Water absorption/Absorption d'eau/ Wasseraufnahme/Waterabsorptie/ Absorción de agua	UNI EN ISO 10545/3	≤ 0,5 %	0,2%	0,2%	0,2%	
	Resistenza alla flessione/Flexual Strenght/Résistance à la flexion/ Biegefestigkeit/Buigvastheid/ Resistencia a la flexión	UNI EN ISO 10545/4	≥ 35 N/mm <sup>2</sup>  S ≥ 1300 N (thickness ≥ 7,5 mm)	Conforme Compliant	Conforme Compliant	Conforme Compliant	
	Coefficiente di restituzione (COR)/ Coefficient of restitution (COR)/ Coefficient de restitution (COR)/ Schlagfestigkeit (COR)/ Restitutiecoëfficiënt (COR)/ Coeficiente de restitución (COR)	UNI EN ISO 10545/5	Valore consigliato ≥ 0,55/ Recommended value ≥ 0,55/ Valeur recommandée ≥ 0,55/ Empfohlener Wert ≥ 0,55/ Aanbevolen waarde ≥ 0,55/ Ralor recomendado ≥ 0,55	Conforme Compliant	Conforme Compliant	Conforme Compliant	
	Resistenza all'abrasione profonda/ Deep abrasion resistance/ Resistance à l'abrasion/ Widerstand gegen Tiefenverschleiß/ Weerstand tegen afschuren/ Resistencia a la abrasión profunda	UNI EN ISO 10545/6	≤ 175 mm <sup>3</sup>	Conforme Compliant	Conforme Compliant	Conforme Compliant	
	Resistenza all'abrasione/ Abrasion resistance/ Résistance à l'abrasion/ Abriebbeständigkeit/ Weerstand tegen afschuring/ Resistencia a la abrasión	UNI EN ISO 10545/7	PEI Solo per piastrelle smaltate / Only for glazed tiles				
	Coefficiente di dilatazione termica lineare/Coefficient of thermal linear expansion/Coefficient de dilatation thermique lineare/Lineare Wärmeausdehnungskoeffizient/ Lineaire thermische uitzetting/ Coeficiente de dilatación termica lineare	UNI EN ISO 10545/8	Metodo di prova disponibile/Tests method available/ Methode d'essai disponible/Verfügbares/Prüfverfahren/ Testmethode beschikbaar/Método de prueba disponible	≤ 7 10 <sup>-6</sup> •C <sup>-1</sup>	≤ 7 10 <sup>-6</sup> •C <sup>-1</sup>	≤ 7 10 <sup>-6</sup> •C <sup>-1</sup>	≤ 7 10 <sup>-6</sup> •C <sup>-1</sup>
	Resistenza agli sbalzi termici/ Thermal shock resistance/ Resistance aux écarts de temperature/ Temperaturwechselbeständigkeit/ Temperatuurswisselingen/ Resistencia al choque térmico	UNI EN ISO 10545/9	Nessun campione deve presentare difetti visibili/ No sample must show visible defects/ Aucun échantillon ne doit présenter des défauts visibles/ Kein Exemplar darf sichtbare Schäden aufweisen/ Geen enkel monster mag zichtbare gebreken vertonen/ Ninguna muestra debe presentar defectos visibles	Conforme Compliant	Conforme Compliant	Conforme Compliant	Conforme Compliant
	Dilatazione all'umidità/Moisture expansion/Dilatation à l'humidité/ Feuchtigkeitsausdehnung/ Uitzetting door vocht/Dilatación por la humedad	UNI EN ISO 10545/10	Metodo di prova disponibile/Tests method available/ Methode d'essai disponible/Verfügbares/Prüfverfahren/ Testmethode beschikbaar/Método de prueba disponible	≤ 0,01 % (0,1 mm/m)	≤ 0,01 % (0,1 mm/m)	≤ 0,01 % (0,1 mm/m)	≤ 0,01 % (0,1 mm/m)
	Resistenza al fuoco/ Fire resistance/ Résistance au feu/ Brandverhalten/ Brand weerstand/ Resistencia al fuego	UNI EN ISO 13501-1	Dichiarare un valore / Declare a value  Classe A1 oppure A <sub>1s</sub> / Class A1 or A <sub>1s</sub>	A <sub>1s</sub>	A <sub>1s</sub>	A <sub>1s</sub>	A <sub>1s</sub>
	Resistenza al gelo/Frost resistance/Résistance au gel/Frostbeständigkeit/ Vorstbestandheid/ Resistencia a la helada	UNI EN ISO 10545/12	Resistenti/Resistant/Resistants/ Widerstandsfähig/ Weerbaarstig/Resistentes	Conforme Compliant	Conforme Compliant	Conforme Compliant	Conforme Compliant











\* Per piastrelle rettangolari, che abbiano il lato maggiore L ≥ 60 cm, e rapporto tra i lati ≥ 3, la misurazione della ortogonalità deve venire condotta solo sul lato corto.  
For oblong tiles with L ≥ 60 cm and ratio length/width L/W ≥ 3, measurement of rectangularity only on short edges

## Gres Fine Porcellanato – EN 14411 ISO 13006 Gruppo Bla Annex G

	Regulation	Required standards	Epoque	Essence	Flake	Foil	
 <b>Resistenza all'attacco chimico/</b> <b>Chemical resistance/Resistance</b> <b>à l'attaque chimique/Beständigkeit</b> <b>gegen Chemikalien/Chemische</b> <b>bestandheid/Resistencia al ataque</b> <b>químico</b>	UNI EN ISO 10545/13						
		Resistenza ai prodotti chimici di uso domestico ed agli additivi per piscina / Resistance to household chemicals and swimming pool salts	Classe minima B (GB per piastrelle smaltate) / Minimum class B (GB for glazed tiles)	A	A	A	A
		Resistenza a basse concentrazioni di acidi e alcali / Resistance to low concentrations of acids and alkalis	Classe minima B (UB per piastrelle non smaltate) / Minimum class B (UB for unglazed tiles)	LA	LA	LA	LA
		Resistenza ad alte concentrazioni di acidi e alcali / Resistance to high concentrations of acids and alkalis	Dichiarare una classe / Declare a class Metodo di prova disponibile / Tests method available	HA	HA	HA	HA
 <b>Resistenza alle macchie/Stain</b> <b>resistance/Insensibilité aux</b> <b>taches/Beständigkeit gegen</b> <b>Fleckenbildner/Substanzen/</b> <b>Weerstand tegen vlekken/</b> <b>Resistencia a las manchas</b>	UNI EN ISO 10545/14	UGL Dichiarare un valore / UGL Declare a value  GL ≥ 3	Classe 5 Class 5	Classe 5 Class 5	Classe 5 Class 5	Classe 5 Class 5	
 <b>Cessione di piombo e cadmio/</b> <b>Lead and cadmium discharge/</b> <b>Perte de plomb et cadmium/</b> <b>Abgabe von Blei und Cadmium/</b> <b>Ontdaan van lood en cadmium/</b> <b>Cesión de plomo y cadmio</b>	UNI EN ISO 10545/15	Valore dichiarato per piastrelle GL / Declared value for GL tiles					
 <b>Indicazione di resistenza allo</b> <b>scivolamento/Assessment</b> <b>of slip resistance/Indication</b> <b>de la résistance au glissement/</b> <b>Bestimmung der Trittsicherheit/</b> <b>Indicatie voor de slipvastheid/</b> <b>Indicación de resistencia al</b> <b>deslizamiento</b>	DIN 51130	Dichiarare un valore (R) / Declare a value (R)	R10	R10 R11 Strutt. R11 OUT2.0	R10 Matt	R10	
	DIN 51097	Dichiarare un valore (A+B+C) / Declare a value (A+B+C)	A+B Inlay	A+B	A+B Matt		
	BS 7976-2:2002 (CEN/TS 16165, Annex C) Pendulum Friction Test	Dichiarare un valore / Declare a value	≥ 36 Wet	≥ 36 Wet	≥ 36 Wet Matt	≥ 36 Wet	
 <b>Coefficiente di attrito dinamico/</b> <b>Measurement of dynamic</b> <b>coefficient of friction/</b> <b>Mesure du coefficient de</b> <b>frottement dynamique/</b> <b>Messung des dynamischen</b> <b>Reibungskoeffizienten/</b> <b>Meting van de dynamische</b> <b>wrijvingscoefficient/Coefficiente de</b> <b>rozamiento dinámico</b>	B.C.R.A. Rep. CEC/31	Asciutto > 0,40 / Bagnato > 0,40	Asciutto > 0,40 / Bagnato > 0,40	Asciutto > 0,40 / Bagnato > 0,40	Asciutto > 0,40 / Bagnato > 0,40 Matt/Soft	Asciutto > 0,40 / Bagnato > 0,40	
	ANSI A137.1- 2012 (BOT3000)	> 0,42 Wet	> 0,42 Wet	> 0,42 Wet	> 0,42 Wet Matt/Soft	> 0,42 Wet	





I valori indicati nella tabella si riferiscono a superfici naturali (non Lappato)/The values in the table refer to natural (not Lappato - honed) surfaces /Les valeurs du tableau se rapportent à des surfaces naturelle (non Lappato - adoucis)/Die in der Tabelle angeführten Werte beziehen sich auf naturbelassene (nicht Lappato - geläppte) Oberflächen/ De waarden in de tabel hebben betrekking op natuurlijke oppervlakken (niet Lappato - Zijdeglans)/Los valores indicados en la tabla se refieren a las superficies naturales (no Lappato - semipulido)

## Gres Fine Porcellanato – EN 14411 ISO 13006 Gruppo Bla Annex G











	Regulation	Required standards	Fornace	Fusion	Gaja	Giant
	Dimensioni/Sizes/Dimensions/ Abmessungen/Afmetingen/ Dimensiones	UNI EN ISO 10545/2	Non rettificato Not rectified	Rettificato * Rectified *		
		→ Lunghezza e larghezza/Length and width/Longueur et largeur/Länge und Breite/Lengte en breedte/Longitud y anchura	± 0,6 % max 2mm	± 0,3 % max 1mm		
	* According to ISO 13006.	→ Spessore/Thickness/Epaisseur/ Stärke/Dicke/Grosor	± 5 % max 0,5mm	± 5 % max 0,5mm		
		→ Rettilinearità spigoli/Linearity/Rectitude des arêtes/ Kantengeradheit/Rechtheid kanten/Rectitud de los lados	± 0,5 % max 1,5mm	± 0,3 % max 0,8mm	Conforme Compliant	Conforme Compliant
		→ * Ortogonalità/Wedging/Orthogonalité/ Rechtwinkligkei/Haaksheid hoeken/Ortogonalidad	± 0,5 % max 2mm	± 0,3 % max 1,5mm		
		→ Planarità/Warpage/Planéité/Ebenflächigkeit/ Vlakheid/Planitud	± 0,5 % max 2mm	± 0,4 % max 1,8mm		
	Assorbimento acqua/Water absorption/Absorption d'eau/ Wasseraufnahme/Waterabsorptie/ Absorción de agua	UNI EN ISO 10545/3	≤ 0,5 %	0,2%	0,2%	0,2%
	Resistenza alla flessione/Flexual Strenght/Résistance à la flexion/ Biegefestigkeit/Buigvastheid/ Resistencia a la flexión	UNI EN ISO 10545/4	≥ 35 N/mm <sup>2</sup>  S ≥ 1300 N (thickness ≥ 7,5 mm)	Conforme Compliant	Conforme Compliant	Conforme Compliant
	Coefficiente di restituzione (COR)/ Coefficient of restitution (COR)/ Coefficient de restitution (COR)/ Schlagfestigkeit (COR)/ Restitutiecoëfficiënt (COR)/ Coeficiente de restitución (COR)	UNI EN ISO 10545/5	Valore consigliato ≥ 0,55/ Recommended value ≥ 0,55/ Valeur recommandée ≥ 0,55/ Empfohlener Wert ≥ 0,55/ Aanbevolen waarde ≥ 0,55/ Ralor recomendado ≥ 0,55	Conforme Compliant	Conforme Compliant	Conforme Compliant
	Resistenza all'abrasione profonda/ Deep abrasion resistance/ Resistance à l'abrasion/ Widerstand gegen Tiefenverschleiß/ Weerstand tegen afschuren/ Resistencia a la abrasión profunda	UNI EN ISO 10545/6	≤ 175 mm <sup>3</sup>	Conforme Compliant	Conforme Compliant	Conforme Compliant
	Resistenza all'abrasione/ Abrasion resistance/ Résistance à l'abrasion/ Abriebbeständigkeit/ Weerstand tegen afschuring/ Resistencia a la abrasión	UNI EN ISO 10545/7	PEI Solo per piastrelle smaltate / Only for glazed tiles			
	Coefficiente di dilatazione termica lineare/Coefficient of thermal linear expansion/Coefficient de dilatation thermique lineare/Lineare Wärmeausdehnungskoeffizient/ Lineaire thermische uitzetting/ Coeficiente de dilatación termica lineare	UNI EN ISO 10545/8	Metodo di prova disponibile/Tests method available/ Methode d'essai disponible/Verfügbares/Prüfverfahren/ Testmethode beschikbaar/Método de prueba disponible	≤ 7 10 <sup>-6</sup> •C <sup>-1</sup>	≤ 7 10 <sup>-6</sup> •C <sup>-1</sup>	≤ 7 10 <sup>-6</sup> •C <sup>-1</sup>
	Resistenza agli sbalzi termici/ Thermal shock resistance/ Resistance aux écarts de temperature/ Temperaturwechselbeständigkeit/ Temperatuurswisselingen/ Resistencia al choque térmico	UNI EN ISO 10545/9	Nessun campione deve presentare difetti visibili/ No sample must show visible defects/ Aucun échantillon ne doit présenter des défauts visibles/ Kein Exemplar darf sichtbare Schäden aufweisen/ Geen enkel monster mag zichtbare gebreken vertonen/ Ninguna muestra debe presentar defectos visibles	Conforme Compliant	Conforme Compliant	Conforme Compliant
	Dilatazione all'umidità/Moisture expansion/Dilatation à l'humidité/ Feuchtigkeitsausdehnung/ Uitzetting door vocht/Dilatación por la humedad	UNI EN ISO 10545/10	Metodo di prova disponibile/Tests method available/ Methode d'essai disponible/Verfügbares/Prüfverfahren/ Testmethode beschikbaar/Método de prueba disponible	≤ 0,01 % (0,1 mm/m)	≤ 0,01 % (0,1 mm/m)	≤ 0,01 % (0,1 mm/m)
	Resistenza al fuoco/ Fire resistance/ Résistance au feu/ Brandverhalten/ Brand weerstand/ Resistencia al fuego	UNI EN ISO 13501-1	Dichiarare un valore / Declare a value  Classe A1 oppure A <sub>1s</sub> / Class A1 or A <sub>1s</sub>	A <sub>1s</sub>	A <sub>1s</sub>	A <sub>1s</sub>
	Resistenza al gelo/Frost resistance/Résistance au gel/Frostbeständigkeit/ Vorstbestandheid/ Resistencia a la helada	UNI EN ISO 10545/12	Resistenti/Resistant/Resistants/ Widerstandsfähig/ Weerbaarstig/Resistentes	Conforme Compliant	Conforme Compliant	Conforme Compliant

\* Per piastrelle rettangolari, che abbiano il lato maggiore L ≥ 60 cm, e rapporto tra i lati ≥ 3, la misurazione della ortogonalità deve venire condotta solo sul lato corto.  
For oblong tiles with L ≥ 60 cm and ratio length/width L/W ≥ 3, measurement of rectangularity only on short edges

## Gres Fine Porcellanato – EN 14411 ISO 13006 Gruppo Bla Annex G





	Regulation	Required standards	Fornace	Fusion	Gaja	Giant	
 <b>Resistenza all'attacco chimico/</b> <b>Chemical resistance/Resistance</b> <b>à l'attaque chimique/Beständigkeit</b> <b>gegen Chemikalien/Chemische</b> <b>bestandheid/Resistencia al ataque</b> <b>químico</b>	UNI EN ISO 10545/13						
		Resistenza ai prodotti chimici di uso domestico ed agli additivi per piscina / Resistance to household chemicals and swimming pool salts	Classe minima B (GB per piastrelle smaltate) / Minimum class B (GB for glazed tiles)	A	A	A	A
		Resistenza a basse concentrazioni di acidi e alcali / Resistance to low concentrations of acids and alkalis	Classe minima B (UB per piastrelle non smaltate) / Minimum class B (UB for unglazed tiles)	LA	LA	LA	LA
		Resistenza ad alte concentrazioni di acidi e alcali / Resistance to high concentrations of acids and alkalis	Dichiarare una classe / Declare a class Metodo di prova disponibile / Tests method available	HA	HA	HA	HA
 <b>Resistenza alle macchie/Stain</b> <b>resistance/Insensibilité aux</b> <b>taches/Beständigkeit gegen</b> <b>Fleckenbildner/Substanzen/</b> <b>Weerstand tegen vlekken/</b> <b>Resistencia a las manchas</b>	UNI EN ISO 10545/14	UGL Dichiarare un valore / UGL Declare a value  GL ≥ 3	Classe 5 Class 5	Classe 5 Class 5	Classe 5 Class 5	Classe 5 Class 5	
 <b>Cessione di piombo e cadmio/</b> <b>Lead and cadmium discharge/</b> <b>Perte de plomb et cadmium/</b> <b>Abgabe von Blei und Cadmium/</b> <b>Ontaan van lood en cadmium/</b> <b>Cesión de plomo y cadmio</b>	UNI EN ISO 10545/15	Valore dichiarato per piastrelle GL / Declared value for GL tiles					
 <b>Indicazione di resistenza allo</b> <b>scivolamento/Assessment</b> <b>of slip resistance/Indication</b> <b>de la résistance au glissement/</b> <b>Bestimmung der Trittsicherheit/</b> <b>Indicatie voor de slipvastheid/</b> <b>Indicación de resistencia al</b> <b>deslizamiento</b>	DIN 51130	Dichiarare un valore (R) / Declare a value (R)	R10 R11 GRIP R11 OUT2.0	R9 White, Beige R10 Ash	R10 R11 OUT2.0	R9	
	DIN 51097	Dichiarare un valore (A+B+C) / Declare a value (A+B+C)	A+B+C OUT2.0	A+B+C			
	BS 7976-2:2002 (CEN/TS 16165, Annex C) Pendulum Friction Test	Dichiarare un valore / Declare a value	≥ 36 Wet	≥ 36 Wet			
 <b>Coefficiente di attrito dinamico/</b> <b>Measurement of dynamic</b> <b>coefficient of friction/</b> <b>Mesure du coefficient de</b> <b>frottement dynamique/</b> <b>Messung des dynamischen</b> <b>Reibungskoeffizienten/</b> <b>Meting van de dynamische</b> <b>wrijvingscoefficient/Coefficiente de</b> <b>rozamiento dinámico</b>	B.C.R.A. Rep. CEC/31	Asciutto > 0,40 / Bagnato > 0,40	Asciutto > 0,40 / Bagnato > 0,40	Asciutto > 0,40 / Bagnato > 0,40	Asciutto > 0,40 / Bagnato > 0,40	Asciutto > 0,40 / Bagnato > 0,40	
	ANSI A137.1- 2012 (BOT3000)	> 0,42 Wet	> 0,42 Wet	> 0,42 Wet	> 0,42 Wet	> 0,42 Wet	

## Gres Fine Porcellanato – EN 14411 ISO 13006 Gruppo Bla Annex G

	Regulation	Required standards	Graffiti	Grecale	Kasai	Larix
	Dimensioni/Sizes/Dimensions/ Abmessungen/Afmetingen/ Dimensiones	UNI EN ISO 10545/2	Non rettificato Not rectified	Rettificato * Rectified *		
		→ Lunghezza e larghezza/Length and width/Longueur et largeur/Länge und Breite/Lengte en breedte/Longitud y anchura	± 0,6 % max 2mm	± 0,3 % max 1mm		
	* According to ISO 13006.	→ Spessore/Thickness/Epaisseur/ Stärke/Dicke/Grosor	± 5 % max 0,5mm	± 5 % max 0,5mm		
		→ Rettilinearità spigoli/Linearity/Rectitude des arêtes/ Kantengeradheit/Rechtheid kanten/Rectitud de los lados	± 0,5 % max 1,5mm	± 0,3 % max 0,8mm	Conforme Compliant	Conforme Compliant
		→ * Ortogonalità/Wedging/Orthogonalité/ Rechtwinkligkei/Haaksheid hoeken/Ortogonalidad	± 0,5 % max 2mm	± 0,3 % max 1,5mm		
		→ Planarità/Warpage/Planéité/Ebenflächigkeit/ Vlakheid/Planitud	± 0,5 % max 2mm	± 0,4 % max 1,8mm		
	Assorbimento acqua/Water absorption/Absorption d'eau/ Wasseraufnahme/Waterabsorptie/ Absorción de agua	UNI EN ISO 10545/3	≤ 0,5 %	0,2%	0,2%	0,2%
	Resistenza alla flessione/Flexual Strenght/Résistance à la flexion/ Biegefestigkeit/Buigvastheid/ Resistencia a la flexión	UNI EN ISO 10545/4	≥ 35 N/mm <sup>2</sup>  S ≥ 1300 N (thickness ≥ 7,5 mm)	Conforme Compliant	Conforme Compliant	Conforme Compliant
	Coefficiente di restituzione (COR)/ Coefficient of restitution (COR)/ Coefficient de restitution (COR)/ Schlagfestigkeit (COR)/ Restitutiecoëfficiënt (COR)/ Coeficiente de restitución (COR)	UNI EN ISO 10545/5	Valore consigliato ≥ 0,55/ Recommended value ≥ 0,55/ Valeur recommandée ≥ 0,55/ Empfohlener Wert ≥ 0,55/ Aanbevolen waarde ≥ 0,55/ Ralor recomendado ≥ 0,55	Conforme Compliant	Conforme Compliant	Conforme Compliant
	Resistenza all'abrasione profonda/ Deep abrasion resistance/ Resistance à l'abrasion/ Widerstand gegen Tiefenverschleiß/ Weerstand tegen afschuren/ Resistencia a la abrasión profunda	UNI EN ISO 10545/6	≤ 175 mm <sup>3</sup>	Conforme Compliant	Conforme Compliant	Conforme Compliant
	Resistenza all'abrasione/ Abrasion resistance/ Résistance à l'abrasion/ Abriebbeständigkeit/ Weerstand tegen afschuring/ Resistencia a la abrasión	UNI EN ISO 10545/7	PEI Solo per piastrelle smaltate / Only for glazed tiles			
	Coefficiente di dilatazione termica lineare/Coefficient of thermal linear expansion/Coefficient de dilatation thermique lineare/Lineare Wärmeausdehnungskoeffizient/ Lineaire thermische uitzetting/ Coeficiente de dilatación termica linear	UNI EN ISO 10545/8	Metodo di prova disponibile/Tests method available/ Methode d'essai disponible/Verfügbares/Prüfverfahren/ Testmethode beschikbaar/Método de prueba disponible	≤ 7 10 <sup>-6</sup> •C <sup>-1</sup>	≤ 7 10 <sup>-6</sup> •C <sup>-1</sup>	≤ 7 10 <sup>-6</sup> •C <sup>-1</sup>
	Resistenza agli sbalzi termici/ Thermal shock resistance/ Resistance aux écarts de temperature/ Temperaturwechselbeständigkeit/ Temperatuurswisselingen/ Resistencia al choque térmico	UNI EN ISO 10545/9	Nessun campione deve presentare difetti visibili/ No sample must show visible defects/ Aucun échantillon ne doit présenter des défauts visibles/ Kein Exemplar darf sichtbare Schäden aufweisen/ Geen enkel monster mag zichtbare gebreken vertonen/ Ninguna muestra debe presentar defectos visibles	Conforme Compliant	Conforme Compliant	Conforme Compliant
	Dilatazione all'umidità/Moisture expansion/Dilatation à l'humidité/ Feuchtigkeitsausdehnung/ Uitzetting door vocht/Dilatación por la humedad	UNI EN ISO 10545/10	Metodo di prova disponibile/Tests method available/ Methode d'essai disponible/Verfügbares/Prüfverfahren/ Testmethode beschikbaar/Método de prueba disponible	≤ 0,01 % (0,1 mm/m)	≤ 0,01 % (0,1 mm/m)	≤ 0,01 % (0,1 mm/m)
	Resistenza al fuoco/ Fire resistance/ Résistance au feu/ Brandverhalten/ Brand weerstand/ Resistencia al fuego	UNI EN ISO 13501-1	Dichiarare un valore / Declare a value  Classe A1 oppure A <sub>1s</sub> / Class A1 or A <sub>1s</sub>	A <sub>1s</sub>	A <sub>1s</sub>	A <sub>1s</sub>
	Resistenza al gelo/Frost resistance/Résistance au gel/Frostbeständigkeit/ Vorstbestandheid/ Resistencia a la helada	UNI EN ISO 10545/12	Resistenti/Resistant/Resistants/ Widerstandsfähig/ Weerbaarstig/Resistentes	Conforme Compliant	Conforme Compliant	Conforme Compliant

\* Per piastrelle rettangolari, che abbiano il lato maggiore L ≥ 60 cm, e rapporto tra i lati ≥ 3, la misurazione della ortogonalità deve venire condotta solo sul lato corto.  
For oblong tiles with L ≥ 60 cm and ratio length/width L/W ≥ 3, measurement of rectangularity only on short edges











## Gres Fine Porcellanato – EN 14411 ISO 13006 Gruppo Bla Annex G

	Regulation	Required standards	Graffiti	Grecale	Kasai	Larix	
 <b>Resistenza all'attacco chimico/</b> <b>Chemical resistance/Resistance</b> <b>à l'attaque chimique/Beständigkeit</b> <b>gegen Chemikalien/Chemische</b> <b>bestandheid/Resistencia al ataque</b> <b>químico</b>	UNI EN ISO 10545/13						
		Resistenza ai prodotti chimici di uso domestico ed agli additivi per piscina / Resistance to household chemicals and swimming pool salts	Classe minima B (GB per piastrelle smaltate) / Minimum class B (GB for glazed tiles)	A	A	A	A
		Resistenza a basse concentrazioni di acidi e alcali / Resistance to low concentrations of acids and alkalis	Classe minima B (UB per piastrelle non smaltate) / Minimum class B (UB for unglazed tiles)	LA	LA	LA	LA
		Resistenza ad alte concentrazioni di acidi e alcali / Resistance to high concentrations of acids and alkalis	Dichiarare una classe / Declare a class Metodo di prova disponibile / Tests method available	HA	HA	HA	HA
 <b>Resistenza alle macchie/Stain</b> <b>resistance/Insensibilité aux</b> <b>taches/Beständigkeit gegen</b> <b>Fleckenbildner/Substanzen/</b> <b>Weerstand tegen vlekken/</b> <b>Resistencia a las manchas</b>	UNI EN ISO 10545/14	UGL Dichiarare un valore / UGL Declare a value	Classe 5 Class 5	Classe 5 Class 5	Classe 5 Class 5	Classe 5 Class 5	
		GL ≥ 3					
 <b>Cessione di piombo e cadmio/</b> <b>Lead and cadmium discharge/</b> <b>Perte de plomb et cadmium/</b> <b>Abgabe von Blei und Cadmium/</b> <b>Ontdaan van lood en cadmium/</b> <b>Cesión de plomo y cadmio</b>	UNI EN ISO 10545/15	Valore dichiarato per piastrelle GL / Declared value for GL tiles					
 <b>Indicazione di resistenza allo</b> <b>scivolamento/Assessment</b> <b>of slip resistance/Indication</b> <b>de la résistance au glissement/</b> <b>Bestimmung der Trittsicherheit/</b> <b>Indicatie voor de slipvastheid/</b> <b>Indicación de resistencia al</b> <b>deslizamiento</b>	DIN 51130	Dichiarare un valore (R) / Declare a value (R)	R10	R10 Matt	R10	R10 R11 OUT20	
	DIN 51097	Dichiarare un valore (A+B+C) / Declare a value (A+B+C)	A+B			A+B	
	BS 7976-2:2002 (CEN/TS 16165, Annex C) Pendulum Friction Test	Dichiarare un valore / Declare a value	≥ 36 Wet	≥ 36 Wet Matt	≥ 36 Wet	≥ 36 Wet	
 <b>Coefficiente di attrito dinamico/</b> <b>Measurement of dynamic</b> <b>coefficient of friction/</b> <b>Mesure du coefficient de</b> <b>frottement dynamique/</b> <b>Messung des dynamischen</b> <b>Reibungskoeffizienten/</b> <b>Meting van de dynamische</b> <b>wrijvingscoefficient/Coefficiente de</b> <b>rozamiento dinámico</b>	B.C.R.A. Rep. CEC/81	Asciutto > 0,40 / Bagnato > 0,40	Asciutto > 0,40 / Bagnato > 0,40	Asciutto > 0,40 / Bagnato > 0,40 Matt/Soft	Asciutto > 0,40 / Bagnato > 0,40	Asciutto > 0,40 / Bagnato > 0,40	
	ANSI A137.1- 2012 (BOT3000)	> 0,42 Wet	> 0,42 Wet	> 0,42 Wet Matt/Soft	> 0,42 Wet	> 0,42 Wet	

I valori indicati nella tabella si riferiscono a superfici naturali (non Lappato)/The values in the table refer to natural (not Lappato - honed) surfaces /Les valeurs du tableau se rapportent à des surfaces naturelle (non Lappato - adoucisé)/Die in der Tabelle angeführten Werte beziehen sich auf naturbelassene (nicht Lappato - geläppte) Oberflächen/De waarden in de tabel hebben betrekking op natuurlijke oppervlakken (niet Lappato - Zijdeglans)/Los valores indicados en la tabla se refieren a las superficies naturales (no Lappato - semipulido)







## Gres Fine Porcellanato – EN 14411 ISO 13006 Gruppo Bla Annex G

	Regulation	Required standards	Mansion	Mold	Petrae	Pietra di Cembra	
	Dimensioni/Sizes/Dimensions/ Abmessungen/Afmetingen/ Dimensiones	UNI EN ISO 10545/2	Non rettificato Not rectified	Rettificato * Rectified *			
		→ Lunghezza e larghezza/Length and width/Longueur et largeur/Länge und Breite/Lengte en breedte/ Longitud y anchura	± 0,6 % max 2mm	± 0,3 % max 1mm			
	* According to ISO 13006.	→ Spessore/Thickness/Epaisseur/ Stärke/Dicke/Grosor	± 5 % max 0,5mm	± 5 % max 0,5mm			
		→ Rettileità spigoli/Linearity/Rectitude des arêtes/ Kantengeradheit/Rechtheid kanten/Rectitud de los lados	± 0,5 % max 1,5mm	± 0,3 % max 0,8mm	Conforme Compliant	Conforme Compliant	
		→ * Ortogonalità/Wedging/Orthogonalité/ Rechtwinkligkeit/Haaksheid hoeken/Ortogonalidad	± 0,5 % max 2mm	± 0,3 % max 1,5mm			
		→ Planarità/Warpage/Planéité/Ebenflächigkeit/ Vlakheid/Planitud	± 0,5 % max 2mm	± 0,4 % max 1,8mm			
	Assorbimento acqua/Water absorption/Absorption d'eau/ Wasseraufnahme/Waterabsorptie/ Absorción de agua	UNI EN ISO 10545/3	≤ 0,5 %	0,2%	0,2%	0,2%	
	Resistenza alla flessione/Flexual Strenght/Résistance à la flexion/ Biegefestigkeit/Buigvastheid/ Resistencia a la flexión	UNI EN ISO 10545/4	≥ 35 N/mm <sup>2</sup>  S ≥ 1300 N (thickness ≥ 7,5 mm)	Conforme Compliant	Conforme Compliant	Conforme Compliant	
	Coefficiente di restituzione (COR)/ Coefficient of restitution (COR)/ Coefficient de restitution (COR)/ Schlagfestigkeit (COR)/ Restitutiecoëfficiënt (COR)/ Coeficiente de restitución (COR)	UNI EN ISO 10545/5	Valore consigliato ≥ 0,55/ Recommended value ≥ 0,55/ Valeur recommandée ≥ 0,55/ Empfohlener Wert ≥ 0,55/ Aanbevolen waarde ≥ 0,55/ Rvalor recomendado ≥ 0,55	Conforme Compliant	Conforme Compliant	Conforme Compliant	
	Resistenza all'abrasione profonda/ Deep abrasion resistance/ Resistance à l'abrasion/ Widerstand gegen Tiefenverschleiß/ Weerstand tegen afschuren/ Resistencia a la abrasión profunda	UNI EN ISO 10545/6	≤ 175 mm <sup>3</sup>	Conforme Compliant	Conforme Compliant	Conforme Compliant	
	Resistenza all'abrasione/ Abrasion resistance/ Résistance à l'abrasion/ Abriebbeständigkeit/ Weerstand tegen afschuring/ Resistencia a la abrasión	UNI EN ISO 10545/7	PEI Solo per piastrelle smaltate / Only for glazed tiles				
	Coefficiente di dilatazione termica lineare/Coefficient of thermal linear expansion/Coefficient de dilatation thermique lineair/Lineairer Wärmeausdehnungskoeffizient/ Lineaire thermische uitzetting/ Coeficiente de dilatación termica lineair	UNI EN ISO 10545/8	Metodo di prova disponibile/Tests method available/ Methode d'essai disponible/Verfügbares/Prüfverfahren/ Testmethode beschikbaar/Método de prueba disponible	≤ 7 10 <sup>-6</sup> •C <sup>-1</sup>	≤ 7 10 <sup>-6</sup> •C <sup>-1</sup>	≤ 7 10 <sup>-6</sup> •C <sup>-1</sup>	≤ 7 10 <sup>-6</sup> •C <sup>-1</sup>
	Resistenza agli sbalzi termici/ Thermal shock resistance/ Resistance aux écarts de temperature/ Temperaturwechselbeständigkeit/ Temperatuurswisselingen/ Resistencia al choque térmico	UNI EN ISO 10545/9	Nessun campione deve presentare difetti visibili/ No sample must show visible defects/ Aucun échantillon ne doit présenter des défauts visibles/ Kein Exemplar darf sichtbare Schäden aufweisen/ Geen enkel monster mag zichtbare gebreken vertonen/ Ninguna muestra debe presentar defectos visibles	Conforme Compliant	Conforme Compliant	Conforme Compliant	Conforme Compliant
	Dilatazione all'umidità/Moisture expansion/Dilatation à l'humidité/ Feuchtigkeitsausdehnung/ Uitzetting door vocht/Dilatación por la humedad	UNI EN ISO 10545/10	Metodo di prova disponibile/Tests method available/ Methode d'essai disponible/Verfügbares/Prüfverfahren/ Testmethode beschikbaar/Método de prueba disponible	≤ 0,01 % (0,1 mm/m)	≤ 0,01 % (0,1 mm/m)	≤ 0,01 % (0,1 mm/m)	≤ 0,01 % (0,1 mm/m)
	Resistenza al fuoco/ Fire resistance/ Résistance au feu/ Brandverhalten/ Brand weerstand/ Resistencia al fuego	UNI EN ISO 13501-1	Dichiarare un valore / Declare a value  Classe A1 oppure A <sub>1s</sub> / Class A1 or A <sub>1s</sub>	A <sub>1s</sub>	A <sub>1s</sub>	A <sub>1s</sub>	A <sub>1s</sub>
	Resistenza al gelo/Frost resistance/Résistance au gel/Frostbeständigkeit/ Vorstandigheid/ Resistencia a la helada	UNI EN ISO 10545/12	Resistenti/Resistant/Resistants/ Widerstandsfähig/ Weerbaarstig/Resistentes	Conforme Compliant	Conforme Compliant	Conforme Compliant	Conforme Compliant











\* Per piastrelle rettangolari, che abbiano il lato maggiore L ≥ 60 cm, e rapporto tra i lati ≥ 3, la misurazione della ortogonalità deve venire condotta solo sul lato corto.  
For oblong tiles with L ≥ 60 cm and ratio length/width L/W ≥ 3, measurement of rectangularity only on short edges

Gres Fine Porcellanato – EN 14411 ISO 13006 Gruppo Bla Annex G

	Regulation	Required standards	Mansion	Mold	Petrae	Pietra di Cembra	
 <b>Resistenza all'attacco chimico/ Chemical resistance/Resistance à l'attaque chimique/Beständigkeit gegen Chemikalien/Chemische bestandheid/Resistencia al ataque químico</b>	UNI EN ISO 10545/13						
		Resistenza ai prodotti chimici di uso domestico ed agli additivi per piscina / Resistance to household chemicals and swimming pool salts	Classe minima B (GB per piastrelle smaltate) / Minimum class B (GB for glazed tiles)	A	A	A	A
		Resistenza a basse concentrazioni di acidi e alcali / Resistance to low concentrations of acids and alkalis	Classe minima B (UB per piastrelle non smaltate) / Minimum class B (UB for unglazed tiles)	LA	LA	LA	LA
		Resistenza ad alte concentrazioni di acidi e alcali / Resistance to high concentrations of acids and alkalis	Dichiarare una classe / Declare a class Metodo di prova disponibile / Tests method available	HA	HA	HA	HA
 <b>Resistenza alle macchie/Stain resistance/Insensibilité aux taches/Beständigkeit gegen Fleckenbildner/Substanzen/Weerstand tegen vlekken/Resistencia a las manchas</b>	UNI EN ISO 10545/14	UGL Dichiarare un valore / UGL Declare a value	Classe 5 Class 5	Classe 5 Class 5	Classe 5 Class 5	Classe 5 Class 5	
		GL ≥ 3					
 <b>Cessione di piombo e cadmio/ Lead and cadmium discharge/ Perte de plomb et cadmium/ Abgabe von Blei und Cadmium/ Ontdaan van lood en cadmium/ Cesión de plomo y cadmio</b>	UNI EN ISO 10545/15	Valore dichiarato per piastrelle GL / Declared value for GL tiles					
 <b>Indicazione di resistenza allo scivolamento/Assessment of slip resistance/Indication de la résistance au glissement/ Bestimmung der Trittsicherheit/ Indicatie voor de slipvastheid/ Indicación de resistencia al deslizamiento</b>	DIN 51130	Dichiarare un valore (R) / Declare a value (R)	R10	R10 Matt R11 OUT2.0	R10 Savoie, Pacific, Guyana, Muschelkalk R11 Barge, Bavaria R11 OUT2.0	R10 R11 GRIP R11 OUT2.0	
	DIN 51097	Dichiarare un valore (A+B+C) / Declare a value (A+B+C)	A+B	A+B Matt A+B+C OUT2.0	A+B A+B+C OUT2.0	A+B A+B+C OUT2.0	
	BS 7976-2:2002 (CEN/TS 16165, Annex C) Pendulum Friction Test	Dichiarare un valore / Declare a value		≥ 36 Wet Matt	≥ 36 Wet	≥ 36 Wet	
 <b>Coefficiente di attrito dinamico/ Measurement of dynamic coefficient of friction/ Mesure du coefficient de frottement dynamique/ Messung des dynamischen Reibungskoeffizienten/ Meting van de dynamische wrijvingscoefficient/Coefficiente de rozamiento dinámico</b>	B.C.R.A. Rep. CEC/81	Asciutto > 0,40 / Bagnato > 0,40	Asciutto > 0,40 / Bagnato > 0,40	Asciutto > 0,40 / Bagnato > 0,40 Matt/Soft	Asciutto > 0,40 / Bagnato > 0,40	Asciutto > 0,40 / Bagnato > 0,40	
	ANSI A137.1-2012 (BOT3000)	> 0,42 Wet	> 0,42 Wet	> 0,42 Wet Matt/Soft	> 0,42 Wet	> 0,42 Wet	





I valori indicati nella tabella si riferiscono a superfici naturali (non Lappato)/The values in the table refer to natural (not Lappato - honed) surfaces /Les valeurs du tableau se rapportent à des surfaces naturelle (non Lappato - adoucis)/Die in der Tabelle angeführten Werte beziehen sich auf naturbelassene (nicht Lappato - geläppte) Oberflächen/ De waarden in de tabel hebben betrekking op natuurlijke oppervlakken (niet Lappato - Zijdeglans)/Los valores indicados en la tabla se refieren a las superficies naturales (no Lappato - semipulido)

## Gres Fine Porcellanato – EN 14411 ISO 13006 Gruppo Bla Annex G

	Regulation	Required standards	Pietre di Borgogna	Plain	Plant	Poesia		
 <b>Dimensioni/Sizes/Dimensions/ Abmessungen/Afmetingen/ Dimensiones</b>	UNI EN ISO 10545/2	Non rettificato Not rectified	Rettificato * Rectified *					
		→ Lunghezza e larghezza/Length and width/Longueur et largeur/Länge und Breite/Lengte en breedte/ Longitud y anchura	± 0,6 % max 2mm	± 0,3 % max 1mm				
		* According to ISO 13006.	→ Spessore/Thickness/Epaisseur/ Stärke/Dicke/Grosor	± 5 % max 0,5mm	± 5 % max 0,5mm			
		→ Rettilinearità spigoli/Linearity/Rectitude des arêtes/ Kantengeradheit/Rechtheid kanten/Rectitud de los lados	± 0,5 % max 1,5mm	± 0,3 % max 0,8mm	Conforme Compliant	Conforme Compliant	Conforme Compliant	Conforme Compliant
		→ * Ortogonalità/Wedging/Orthogonalité/ Rechtwinkligkeit/Haaksheid hoeken/Ortogonalidad	± 0,5 % max 2mm	± 0,3 % max 1,5mm				
		→ Planarità/Warpage/Planité/Ebenflächigkeit/ Vlakheid/Planitud	± 0,5 % max 2mm	± 0,4 % max 1,8mm				
 <b>Assorbimento acqua/Water absorption/Absorption d'eau/ Wasseraufnahme/Waterabsorptie/ Absorción de agua</b>	UNI EN ISO 10545/3	≤ 0,5 %	0,2%	0,2%	0,2%	0,2%		
 <b>Resistenza alla flessione/Flexual Strenght/Résistance à la flexion/ Biegefestigkeit/Buigvastheid/ Resistencia a la flexión</b>	UNI EN ISO 10545/4	≥ 35 N/mm <sup>2</sup>	Conforme Compliant	Conforme Compliant	Conforme Compliant	Conforme Compliant		
		S ≥ 1300 N (thickness ≥ 7,5 mm)	Conforme Compliant	Conforme Compliant	Conforme Compliant	Conforme Compliant		
 <b>Coefficiente di restituzione (COR)/ Coefficient of restitution (COR)/ Coefficient de restitution (COR)/ Schlagfestigkeit (COR)/ Restitutiecoëfficiënt (COR)/ Coeficiente de restitución (COR)</b>	UNI EN ISO 10545/5	Valore consigliato ≥ 0,55/ Recommended value ≥ 0,55/ Valeur recommandée ≥ 0,55/ Empfohlener Wert ≥ 0,55/ Aanbevolen waarde ≥ 0,55/ Ralor recomendado ≥ 0,55	Conforme Compliant	Conforme Compliant	Conforme Compliant	Conforme Compliant		
 <b>Resistenza all'abrasione profonda/ Deep abrasion resistance/ Resistance à l'abrasion/ Widerstand gegen Tiefenverschleiß/ Weerstand tegen afschuren/ Resistencia a la abrasión profunda</b>	UNI EN ISO 10545/6	≤ 175 mm <sup>3</sup>	Conforme Compliant	Conforme Compliant	Conforme Compliant	Conforme Compliant		
 <b>Resistenza all'abrasione/ Abrasion resistance/ Résistance à l'abrasion/ Abriebbeständigkeit/ Weerstand tegen afschuring/ Resistencia a la abrasión</b>	UNI EN ISO 10545/7	PEI Solo per piastrelle smaltate / Only for glazed tiles						
 <b>Coefficiente di dilatazione termica lineare/Coefficient of thermal linear expansion/Coefficient de dilatation thermique linear/Lineare Wärmeausdehnungskoeffizient/ Lineaire thermische uitzetting/ Coeficiente de dilatación termica linear</b>	UNI EN ISO 10545/8	Metodo di prova disponibile/Tests method available/ Methode d'essai disponible/Verfügbares/Prüfverfahren/ Testmethode beschikbaar/Método de prueba disponible	≤ 7 10 <sup>-6</sup> •C <sup>-1</sup>	≤ 7 10 <sup>-6</sup> •C <sup>-1</sup>	≤ 7 10 <sup>-6</sup> •C <sup>-1</sup>	≤ 7 10 <sup>-6</sup> •C <sup>-1</sup>		
 <b>Resistenza agli sbalzi termici/ Thermal shock resistance/ Resistance aux écarts de temperature/ Temperaturwechselbeständigkeit/ Temperatuurswisselingen/ Resistencia al choque térmico</b>	UNI EN ISO 10545/9	Nessun campione deve presentare difetti visibili/ No sample must show visible defects/ Aucun échantillon ne doit présenter des défauts visibles/ Kein Exemplar darf sichtbare Schäden aufweisen/ Geen enkel monster mag zichtbare gebreken vertonen/ Ninguna muestra debe presentar defectos visibles	Conforme Compliant	Conforme Compliant	Conforme Compliant	Conforme Compliant		
 <b>Dilatazione all'umidità/Moisture expansion/Dilatation à l'humidité/ Feuchtigkeitsausdehnung/ Uitzetting door vocht/Dilatación por la humedad</b>	UNI EN ISO 10545/10	Metodo di prova disponibile/Tests method available/ Methode d'essai disponible/Verfügbares/Prüfverfahren/ Testmethode beschikbaar/Método de prueba disponible	≤ 0,01 % (0,1 mm/m)	≤ 0,01 % (0,1 mm/m)	≤ 0,01 % (0,1 mm/m)	≤ 0,01 % (0,1 mm/m)		
 <b>Resistenza al fuoco/ Fire resistance/ Résistance au feu/ Brandverhalten/ Brand weerstand/ Resistencia al fuego</b>	UNI EN ISO 13501-1	Dichiarare un valore / Declare a value  Classe A1 oppure A <sub>1s</sub> / Class A1 or A <sub>1s</sub>	A <sub>1s</sub>	A <sub>1s</sub>	A <sub>1s</sub>	A <sub>1s</sub>		
 <b>Resistenza al gelo/Frost resistance/Résistance au gel/Frostbeständigkeit/ Vorstbestandheid/ Resistencia a la helada</b>	UNI EN ISO 10545/12	Resistenti/Resistant/Resistants/ Widerstandsfähig/ Weerbaarstig/Resistentes	Conforme Compliant	Conforme Compliant	Conforme Compliant	Conforme Compliant		











\* Per piastrelle rettangolari, che abbiano il lato maggiore L ≥ 60 cm, e rapporto tra i lati ≥ 3, la misurazione della ortogonalità deve venire condotta solo sul lato corto.  
For oblong tiles with L ≥ 60 cm and ratio length/width L/W ≥ 3, measurement of rectangularity only on short edges

## Gres Fine Porcellanato – EN 14411 ISO 13006 Gruppo Bla Annex G

	Regulation	Required standards	Pietre di Borgogna	Plain	Plant	Poesia	
 <b>Resistenza all'attacco chimico/</b> <b>Chemical resistance/Resistance</b> <b>à l'attaque chimique/Beständigkeit</b> <b>gegen Chemikalien/Chemische</b> <b>bestandheid/Resistencia al ataque</b> <b>químico</b>	UNI EN ISO 10545/13						
		Resistenza ai prodotti chimici di uso domestico ed agli additivi per piscina / Resistance to household chemicals and swimming pool salts	Classe minima B (GB per piastrelle smaltate) / Minimum class B (GB for glazed tiles)	A	A	A	A
		Resistenza a basse concentrazioni di acidi e alcali / Resistance to low concentrations of acids and alkalis	Classe minima B (UB per piastrelle non smaltate) / Minimum class B (UB for unglazed tiles)	LA	LA	LA	LA
		Resistenza ad alte concentrazioni di acidi e alcali / Resistance to high concentrations of acids and alkalis	Dichiarare una classe / Declare a class Metodo di prova disponibile / Tests method available	HA	HA	HA	HA
 <b>Resistenza alle macchie/Stain</b> <b>resistance/Insensibilité aux</b> <b>taches/Beständigkeit gegen</b> <b>Fleckenbildner/Substanzen/</b> <b>Weerstand tegen vlekken/</b> <b>Resistencia a las manchas</b>	UNI EN ISO 10545/14	UGL Dichiarare un valore / UGL Declare a value  GL ≥ 3	Classe 5 Class 5	Classe 5 Class 5	Classe 5 Class 5	Classe 5 Class 5	
 <b>Cessione di piombo e cadmio/</b> <b>Lead and cadmium discharge/</b> <b>Perte de plomb et cadmium/</b> <b>Abgabe von Blei und Cadmium/</b> <b>Ontaan van lood en cadmium/</b> <b>Cesión de plomo y cadmio</b>	UNI EN ISO 10545/15	Valore dichiarato per piastrelle GL / Declared value for GL tiles					
 <b>Indicazione di resistenza allo</b> <b>scivolamento/Assessment</b> <b>of slip resistance/Indication</b> <b>de la résistance au glissement/</b> <b>Bestimmung der Trittsicherheit/</b> <b>Indicatie voor de slipvastheid/</b> <b>Indicación de resistencia al</b> <b>deslizamiento</b>	DIN 51130	Dichiarare un valore (R) / Declare a value (R)	R9 R11 Strutt. R11 OUT2.0	R10 Matt R11 OUT2.0	R10 R11 OUT2.0	R9 R10 Anticata R11 OUT2.0	
	DIN 51097	Dichiarare un valore (A+B+C) / Declare a value (A+B+C)	A+B+C Strutt. A+B+C OUT2.0	A+B Matt A+B+C OUT2.0	A+B A+B+C OUT2.0	A+B A+B+C Anticata A+B+C OUT2.0	
	BS 7976-2:2002 (CEN/TS 16165, Annex C) Pendulum Friction Test	Dichiarare un valore / Declare a value		≥ 36 Wet Matt		≥ 36 Wet Anticata	
 <b>Coefficiente di attrito dinamico/</b> <b>Measurement of dynamic</b> <b>coefficient of friction/</b> <b>Mesure du coefficient de</b> <b>frottement dynamique/</b> <b>Messung des dynamischen</b> <b>Reibungskoeffizienten/</b> <b>Meting van de dynamische</b> <b>wrijvingscoefficient/Coefficiente de</b> <b>rozamiento dinámico</b>	B.C.R.A. Rep. CEC/81	Asciutto > 0,40 / Bagnato > 0,40	Asciutto > 0,40 / Bagnato > 0,40	Asciutto > 0,40 / Bagnato > 0,40 Matt/Soft	Asciutto > 0,40 / Bagnato > 0,40	Asciutto > 0,40 / Bagnato > 0,40	
	ANSI A137.1- 2012 (BOT3000)	> 0,42 Wet	> 0,42 Wet	> 0,42 Wet Matt/Soft	> 0,42 Wet	> 0,42 Wet	





I valori indicati nella tabella si riferiscono a superfici naturali (non Lappato)/The values in the table refer to natural (not Lappato - honed) surfaces /Les valeurs du tableau se rapportent à des surfaces naturelle (non Lappato - adoucis)/Die in der Tabelle angeführten Werte beziehen sich auf naturbelassene (nicht Lappato - geläppte) Oberflächen/ De waarden in de tabel hebben betrekking op natuurlijke oppervlakken (niet Lappato - Zijdeglans)/Los valores indicados en la tabla se refieren a las superficies naturales (no Lappato - semipulido)

## Gres Fine Porcellanato – EN 14411 ISO 13006 Gruppo Bla Annex G











	Regulation	Required standards	Prestigio	Risseu	Stardust	Trail
	Dimensioni/Sizes/Dimensions/ Abmessungen/Afmetingen/ Dimensiones	UNI EN ISO 10545/2	Non rettificato Not rectified	Rettificato* Rectified*		
		→ Lunghezza e larghezza/Length and width/Longueur et largeur/Länge und Breite/Lengte en breedte/ Longitud y anchura	± 0,6 % max 2mm	± 0,3 % max 1mm		
	* According to ISO 13006.	→ Spessore/Thickness/Epaisseur/ Stärke/Dicke/Grosor	± 5 % max 0,5mm	± 5 % max 0,5mm		
		→ Rettilinearità spigoli/Linearity/Rectitude des arêtes/ Kantengeradheit/Rechtheid kanten/Rectitud de los lados	± 0,5 % max 1,5mm	± 0,3 % max 0,8mm	Conforme Compliant	Conforme Compliant
		→ * Ortogonalità/Wedging/Orthogonalité/ Rechtwinkligkei/Haaksheid hoeken/Ortogonalidad	± 0,5 % max 2mm	± 0,3 % max 1,5mm		
		→ Planarità/Warpage/Planéité/Ebenflächigkeit/ Vlakheid/Planitud	± 0,5 % max 2mm	± 0,4 % max 1,8mm		
	Assorbimento acqua/Water absorption/Absorption d'eau/ Wasseraufnahme/Waterabsorptie/ Absorción de agua	UNI EN ISO 10545/3	≤ 0,5 %	0,2%	0,2%	0,2%
	Resistenza alla flessione/Flexual Strenght/Résistance à la flexion/ Biegefestigkeit/Buigvastheid/ Resistencia a la flexión	UNI EN ISO 10545/4	≥ 35 N/mm <sup>2</sup>  S ≥ 1300 N (thickness ≥ 7,5 mm)	Conforme Compliant	Conforme Compliant	Conforme Compliant
	Coefficiente di restituzione (COR)/ Coefficient of restitution (COR)/ Coefficient de restitution (COR)/ Schlagfestigkeit (COR)/ Restitutiecoëfficiënt (COR)/ Coeficiente de restitución (COR)	UNI EN ISO 10545/5	Valore consigliato ≥ 0,55/ Recommended value ≥ 0,55/ Valeur recommandée ≥ 0,55/ Empfohlener Wert ≥ 0,55/ Aanbevolen waarde ≥ 0,55/ Ralor recomendado ≥ 0,55	Conforme Compliant	Conforme Compliant	Conforme Compliant
	Resistenza all'abrasione profonda/ Deep abrasion resistance/ Resistance à l'abrasion/ Widerstand gegen Tiefenverschleiß/ Weerstand tegen afschuren/ Resistencia a la abrasión profunda	UNI EN ISO 10545/6	≤ 175 mm <sup>3</sup>	Conforme Compliant	Conforme Compliant	Conforme Compliant
	Resistenza all'abrasione/ Abrasion resistance/ Résistance à l'abrasion/ Abriebbeständigkeit/ Weerstand tegen afschuring/ Resistencia a la abrasión	UNI EN ISO 10545/7	PEI Solo per piastrelle smaltate / Only for glazed tiles	Lucido: PEI V (> 12000 rev) Botticino, Calacatta, Carrara, Dolomite, Fior di Bosca, Marfil, Phantom PEI IV (12000 rev) Statuario, Travertino PEI IV (6000 rev) Impero PEI IV (2100 rev) Arcadia, Tracia PEI III (750 rev) Marquinia, Pulpis		
	Coefficiente di dilatazione termica lineare/Coefficient of thermal linear expansion/Coefficient de dilatation thermique linear/Linearer Wärmeausdehnungskoeffizient/ Lineaire thermische uitzetting/ Coeficiente de dilatación termica linear	UNI EN ISO 10545/8	Metodo di prova disponibile/Tests method available/ Methode d'essai disponible/Verfügbares/Prüfverfahren/ Testmethode beschikbaar/Método de prueba disponible	≤ 7 · 10 <sup>-6</sup> •C <sup>-1</sup>	≤ 7 · 10 <sup>-6</sup> •C <sup>-1</sup>	≤ 7 · 10 <sup>-6</sup> •C <sup>-1</sup>
	Resistenza agli sbalzi termici/ Thermal shock resistance/ Resistance aux écarts de temperature/ Temperaturwechselbeständigkeit/ Temperatuurswisselingen/ Resistencia al choque térmico	UNI EN ISO 10545/9	Nessun campione deve presentare difetti visibili/ No sample must show visible defects/ Aucun échantillon ne doit présenter des défauts visibles/ Kein Exemplar darf sichtbare Schäden aufweisen/ Geen enkel monster mag zichtbare gebreken vertonen/ Ninguna muestra debe presentar defectos visibles	Conforme Compliant	Conforme Compliant	Conforme Compliant
	Dilatazione all'umidità/Moisture expansion/Dilatation à l'humidité/ Feuchtigkeitsausdehnung/ Uitzetting door vocht/Dilatación por la humedad	UNI EN ISO 10545/10	Metodo di prova disponibile/Tests method available/ Methode d'essai disponible/Verfügbares/Prüfverfahren/ Testmethode beschikbaar/Método de prueba disponible	≤ 0,01 % (0,1 mm/m)	≤ 0,01 % (0,1 mm/m)	≤ 0,01 % (0,1 mm/m)
	Resistenza al fuoco/ Fire resistance/ Résistance au feu/ Brandverhalten/ Brand weerstand/ Resistencia al fuego	UNI EN ISO 13501-1	Dichiarare un valore / Declare a value  Classe A1 oppure A <sub>1s</sub> / Class A1 or A <sub>1s</sub>	A <sub>1n</sub>	A <sub>1n</sub>	A <sub>1n</sub>
	Resistenza al gelo/Frost resistance/Résistance au gel/Frostbeständigkeit/ Vorstbestandheid/ Resistencia a la helada	UNI EN ISO 10545/12	Resistenti/Resistant/Resistants/ Widerstandsfähig/ Weerbarstig/Resistentes	Conforme Compliant	Conforme Compliant	Conforme Compliant

\* Per piastrelle rettangolari, che abbiano il lato maggiore L ≥ 60 cm, e rapporto tra i lati ≥ 3, la misurazione della ortogonalità deve venire condotta solo sul lato corto.  
For oblong tiles with L ≥ 60 cm and ratio length/width L/W ≥ 3, measurement of rectangularity only on short edges

## Gres Fine Porcellanato – EN 14411 ISO 13006 Gruppo Bla Annex G





	Regulation	Required standards	Prestigio	Risseu	Stardust	Trail	
 <b>Resistenza all'attacco chimico/</b> <b>Chemical resistance/Resistance</b> <b>à l'attaque chimique/Beständigkeit</b> <b>gegen Chemikalien/Chemische</b> <b>bestandheid/Resistencia al ataque</b> <b>químico</b>	UNI EN ISO 10545/13						
		Resistenza ai prodotti chimici di uso domestico ed agli additivi per piscina / Resistance to household chemicals and swimming pool salts	Classe minima B (GB per piastrelle smaltate) / Minimum class B (GB for glazed tiles)	A	A	A	A
		Resistenza a basse concentrazioni di acidi e alcali / Resistance to low concentrations of acids and alkalis	Classe minima B (UB per piastrelle non smaltate) / Minimum class B (UB for unglazed tiles)	LA	LA	LA	LA
		Resistenza ad alte concentrazioni di acidi e alcali / Resistance to high concentrations of acids and alkalis	Dichiarare una classe / Declare a class Metodo di prova disponibile / Tests method available	Non valido per la finitura Lucido. / Non valid for Lucido finish.			
 <b>Resistenza alle macchie/Stain</b> <b>resistance/Insensibilité aux</b> <b>taches/Beständigkeit gegen</b> <b>Fleckenbildner/Substanzen/</b> <b>Weerstand tegen vlekken/</b> <b>Resistencia a las manchas</b>	UNI EN ISO 10545/14	UGL Dichiarare un valore / UGL Declare a value	Soft: Classe 5 Class 5	Classe 5 Class 5	Classe 5 Class 5	Classe 5 Class 5	
		GL ≥ 3	Lucido: Conforme Compliant				
 <b>Cessione di piombo e cadmio/</b> <b>Lead and cadmium discharge/</b> <b>Perte de plomb et cadmium/</b> <b>Abgabe von Blei und Cadmium/</b> <b>Ontdaan van lood en cadmium/</b> <b>Cesión de plomo y cadmio</b>	UNI EN ISO 10545/15	Valore dichiarato per piastrelle GL / Declared value for GL tiles	Lucido: Pb < 0,01 mg/dm <sup>2</sup> Cd < 0,001 mg/dm <sup>2</sup>				
 <b>Indicazione di resistenza allo</b> <b>scivolamento/Assessment</b> <b>of slip resistance/Indication</b> <b>de la résistance au glissement/</b> <b>Bestimmung der Trittsicherheit/</b> <b>Indicatie voor de slipvastheid/</b> <b>Indicación de resistencia al</b> <b>deslizamiento</b>	DIN 51130	Dichiarare un valore (R) / Declare a value (R)	R10 Matt	R10 R11 OUT2.0	R10 Matt	R10	
	DIN 51097	Dichiarare un valore (A+B+C) / Declare a value (A+B+C)					
	BS 7976-2:2002 (CEN/TS 16165, Annex C) Pendulum Friction Test	Dichiarare un valore / Declare a value			≥ 36 Wet Matt	≥ 36 Wet	
 <b>Coefficiente di attrito dinamico/</b> <b>Measurement of dynamic</b> <b>coefficient of friction/</b> <b>Mesure du coefficient de</b> <b>frottement dynamique/</b> <b>Messung des dynamischen</b> <b>Reibungskoeffizienten/</b> <b>Meting van de dynamische</b> <b>wrijvingscoefficient/Coefficiente de</b> <b>rozamiento dinámico</b>	B.C.R.A. Rep. CEC/81	Asciutto > 0,40 / Bagnato > 0,40	Asciutto > 0,40 / Bagnato > 0,40 Matt/Soft	Asciutto > 0,40 / Bagnato > 0,40	Asciutto > 0,40 / Bagnato > 0,40 Matt/Soft	Asciutto > 0,40 / Bagnato > 0,40	
	ANSI A137.1- 2012 (BOT3000)	> 0,42 Wet	> 0,42 Wet Matt/Soft	> 0,42 Wet	> 0,42 Wet Matt/Soft	> 0,42 Wet	

## Gres Fine Porcellanato – EN 14411 ISO 13006 Gruppo Bla Annex G

	Regulation	Required standards	Tune	Urbex Style	Vetri	Wide	
	Dimensioni/Sizes/Dimensions/ Abmessungen/Afmetingen/ Dimensiones	UNI EN ISO 10545/2	Non rettificato Not rectified	Rettificato* Rectified*			
		→ Lunghezza e larghezza/Length and width/Longueur et largeur/Länge und Breite/Lengte en breedte/Longitud y anchura	± 0,6 % max 2mm	± 0,3 % max 1mm			
	* According to ISO 13006.	→ Spessore/Thickness/Epaisseur/ Stärke/Dicke/Grosor	± 5 % max 0,5mm	± 5 % max 0,5mm			
		→ Rettilinearità spigoli/Linearity/Rectitude des arêtes/ Kantengeradheit/Rechtheid kanten/Rectitud de los lados	± 0,5 % max 1,5mm	± 0,3 % max 0,8mm	Conforme Compliant	Conforme Compliant	
		→ * Ortogonalità/Wedging/Orthogonalité/ Rechtwinkligkei/Haaksheid hoeken/Ortogonalidad	± 0,5 % max 2mm	± 0,3 % max 1,5mm			
		→ Planarità/Warpage/Planité/Ebenflächigkeit/ Vlakheid/Planitud	± 0,5 % max 2mm	± 0,4 % max 1,8mm			
	Assorbimento acqua/Water absorption/Absorption d'eau/ Wasseraufnahme/Waterabsorptie/ Absorción de agua	UNI EN ISO 10545/3	≤ 0,5 %	0,2%	0,2%	0,2%	
	Resistenza alla flessione/Flexual Strenght/Résistance à la flexion/ Biegefestigkeit/Buigvastheid/ Resistencia a la flexión	UNI EN ISO 10545/4	≥ 35 N/mm <sup>2</sup>  S ≥ 1300 N (thickness ≥ 7,5 mm)	Conforme Compliant	Conforme Compliant	Conforme Compliant	
	Coefficiente di restituzione (COR)/ Coefficient of restitution (COR)/ Coefficient de restitution (COR)/ Schlagfestigkeit (COR)/ Restitutiecoëfficiënt (COR)/ Coeficiente de restitución (COR)	UNI EN ISO 10545/5	Valore consigliato ≥ 0,55/ Recommended value ≥ 0,55/ Valeur recommandée ≥ 0,55/ Empfohlener Wert ≥ 0,55/ Aanbevolen waarde ≥ 0,55/ Ralor recomendado ≥ 0,55	Conforme Compliant	Conforme Compliant	Conforme Compliant	
	Resistenza all'abrasione profonda/ Deep abrasion resistance/ Resistance à l'abrasion/ Widerstand gegen Tiefenverschleiß/ Weerstand tegen afschuren/ Resistencia a la abrasión profunda	UNI EN ISO 10545/6	≤ 175 mm <sup>3</sup>	Conforme Compliant	Conforme Compliant	Conforme Compliant	
	Resistenza all'abrasione/ Abrasion resistance/ Résistance à l'abrasion/ Abriebbeständigkeit/ Weerstand tegen afschuring/ Resistencia a la abrasión	UNI EN ISO 10545/7	PEI Solo per piastrelle smaltate / Only for glazed tiles			PEI III (1500 rev) Acqua PEI V (>12000 rev) Bianco, Naturale PEI IV (2100 rev) Fumé, Bronzo	
	Coefficiente di dilatazione termica lineare/Coefficient of thermal linear expansion/Coefficient de dilatation thermique lineare/Lineare Wärmeausdehnungskoeffizient/ Lineaire thermische uitzetting/ Coeficiente de dilatación termica linear	UNI EN ISO 10545/8	Metodo di prova disponibile/Tests method available/ Methode d'essai disponible/Verfügbares/Prüfverfahren/ Testmethode beschikbaar/Método de prueba disponible	≤ 7 10 <sup>-6</sup> •C <sup>-1</sup>	≤ 7 10 <sup>-6</sup> •C <sup>-1</sup>	≤ 7 10 <sup>-6</sup> •C <sup>-1</sup>	≤ 7 10 <sup>-6</sup> •C <sup>-1</sup>
	Resistenza agli sbalzi termici/ Thermal shock resistance/ Resistance aux ecarts de temperature/ Temperaturwechselbeständigkeit/ Temperatuurswisselingen/ Resistencia al choque térmico	UNI EN ISO 10545/9	Nessun campione deve presentare difetti visibili/ No sample must show visible defects/ Aucun échantillon ne doit présenter des défauts visibles/ Kein Exemplar darf sichtbare Schäden aufweisen/ Geen enkel monster mag zichtbare gebreken vertonen/ Ninguna muestra debe presentar defectos visibles	Conforme Compliant	Conforme Compliant	Conforme Compliant	Conforme Compliant
	Dilatazione all'umidità/Moisture expansion/Dilatation à l'humidité/ Feuchtigkeitsausdehnung/ Uitzetting door vocht/Dilatación por la humedad	UNI EN ISO 10545/10	Metodo di prova disponibile/Tests method available/ Methode d'essai disponible/Verfügbares/Prüfverfahren/ Testmethode beschikbaar/Método de prueba disponible	≤ 0,01 % (0,1 mm/m)	≤ 0,01 % (0,1 mm/m)	≤ 0,01 % (0,1 mm/m)	≤ 0,01 % (0,1 mm/m)
	Resistenza al fuoco/ Fire resistance/ Résistance au feu/ Brandverhalten/ Brand weerstand/ Resistencia al fuego	UNI EN ISO 13501-1	Dichiarare un valore / Declare a value  Classe A1 oppure A <sub>1s</sub> / Class A1 or A <sub>1s</sub>	A <sub>1s</sub>	A <sub>1s</sub>	A <sub>1s</sub>	A <sub>1s</sub>
	Resistenza al gelo/Frost resistance/Résistance au gel/Frostbeständigkeit/ Vorstandigheid/ Resistencia a la helada	UNI EN ISO 10545/12	Resistenti/Resistant/Resistants/ Widerstandsfähig/ Weerbaarstig/Resistentes	Conforme Compliant	Conforme Compliant	Conforme Compliant	Conforme Compliant

\* Per piastrelle rettangolari, che abbiano il lato maggiore L ≥ 60 cm, e rapporto tra i lati ≥ 3, la misurazione della ortogonalità deve venire condotta solo sul lato corto.  
For oblong tiles with L ≥ 60 cm and ratio length/width L/W ≥ 3, measurement of rectangularity only on short edges

## Gres Fine Porcellanato – EN 14411 ISO 13006 Gruppo Bla Annex G

	Regulation	Required standards	Tune	Urbex Style	Vetri	Wide	
 <b>Resistenza all'attacco chimico/</b> <b>Chemical resistance/Resistance</b> <b>à l'attaque chimique/Beständigkeit</b> <b>gegen Chemikalien/Chemische</b> <b>bestandheid/Resistencia al ataque</b> <b>químico</b>	UNI EN ISO 10545/13						
		Resistenza ai prodotti chimici di uso domestico ed agli additivi per piscina / Resistance to household chemicals and swimming pool salts	Classe minima B (GB per piastrelle smaltate) / Minimum class B (GB for glazed tiles)	A	A	A	A
		Resistenza a basse concentrazioni di acidi e alcali / Resistance to low concentrations of acids and alkalis	Classe minima B (UB per piastrelle non smaltate) / Minimum class B (UB for unglazed tiles)	LA	LA		LA
		Resistenza ad alte concentrazioni di acidi e alcali / Resistance to high concentrations of acids and alkalis	Dichiarare una classe / Declare a class Metodo di prova disponibile / Tests method available	HA	HA		HA
 <b>Resistenza alle macchie/Stain</b> <b>resistance/Insensibilité aux</b> <b>taches/Beständigkeit gegen</b> <b>Fleckenbildner/Substanzen/</b> <b>Weerstand tegen vlekken/</b> <b>Resistencia a las manchas</b>	UNI EN ISO 10545/14	UGL Dichiarare un valore / UGL Declare a value	Classe 5 Class 5	Classe 5 Class 5		Classe 5 Class 5	
		GL ≥ 3			Conforme Compliant		
 <b>Cessione di piombo e cadmio/</b> <b>Lead and cadmium discharge/</b> <b>Perte de plomb et cadmium/</b> <b>Abgabe von Blei und Cadmium/</b> <b>Ontdaan van lood en cadmium/</b> <b>Cesión de plomo y cadmio</b>	UNI EN ISO 10545/15	Valore dichiarato per piastrelle GL / Declared value for GL tiles			Pb < 0,01 mg/dm <sup>2</sup> Cd < 0,001 mg/dm <sup>2</sup>		
 <b>Indicazione di resistenza allo</b> <b>scivolamento/Assessment</b> <b>of slip resistance/Indication</b> <b>de la résistance au glissement/</b> <b>Bestimmung der Trittsicherheit/</b> <b>Indicatie voor de slipvastheid/</b> <b>Indicación de resistencia al</b> <b>deslizamiento</b>	DIN 51130	Dichiarare un valore (R) / Declare a value (R)	R10 Matt R11 OUT2.0	R10		R9 R10 Strutt. R11 OUT2.0	
	DIN 51097	Dichiarare un valore (A+B+C) / Declare a value (A+B+C)	A+B Matt A+B+C OUT2.0			A+B Strutt. A+B+C OUT2.0	
	BS 7976-2:2002 (CEN/TS 16165, Annex C) Pendulum Friction Test	Dichiarare un valore / Declare a value	≥ 36 Wet Matt	≥ 36 Wet		≥ 36 Wet Strutt.	
 <b>Coefficiente di attrito dinamico/</b> <b>Measurement of dynamic</b> <b>coefficient of friction/</b> <b>Mesure du coefficient de</b> <b>frottement dynamique/</b> <b>Messung des dynamischen</b> <b>Reibungskoeffizienten/</b> <b>Meting van de dynamische</b> <b>wrijvingscoefficient/Coefficiente de</b> <b>rozamiento dinámico</b>	B.C.R.A. Rep. CEC/81	Asciutto > 0,40 / Bagnato > 0,40	Asciutto > 0,40 / Bagnato > 0,40 Matt/Soft	Asciutto > 0,40 / Bagnato > 0,40		Asciutto > 0,40 / Bagnato > 0,40	
	ANSI A137.1- 2012 (BOT3000)	> 0,42 Wet	> 0,42 Wet Matt/Soft	> 0,42 Wet		> 0,42 Wet	





# Laying sketches

400/401

Schemi di posa/Laying  
 sketches/Schémas de pose/  
 Modulverlegungsbeispiele/  
 Legschemata/Esquemas  
 de colocación

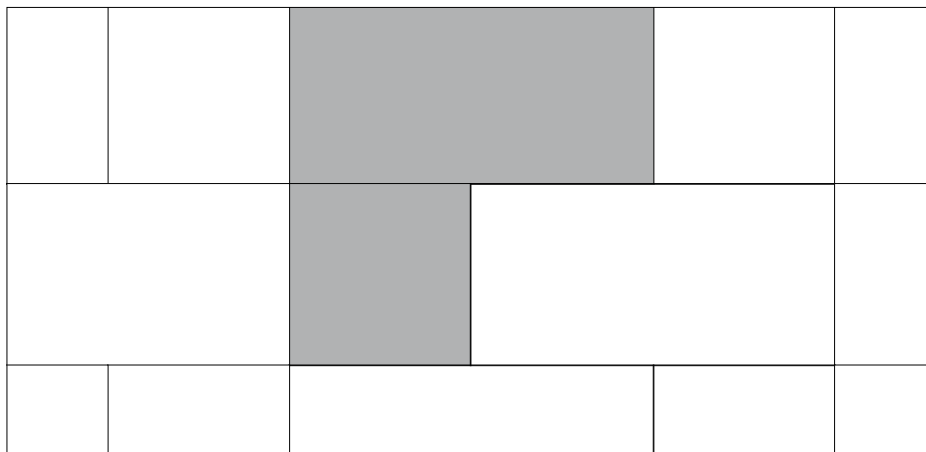

120x240/48"x96"  
 120x120/48"x48"

66,6%  
 33,4%

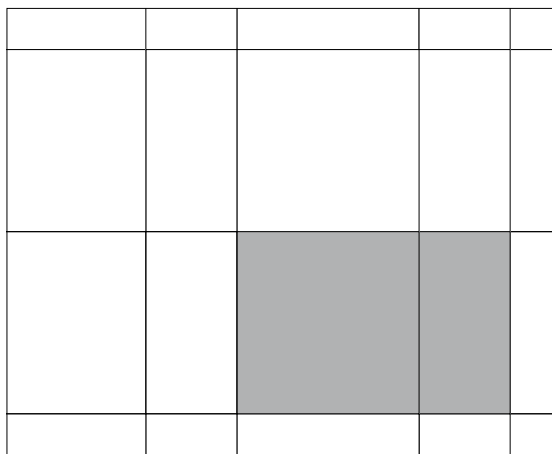

120x120/48"x48"  
 60x120/24"x48"

66,66%  
 33,33%

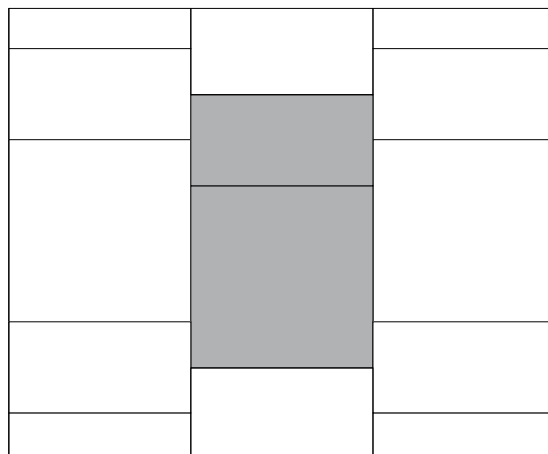

120x120/48"x48"  
 60x120/24"x48"

66,66%  
 33,33%

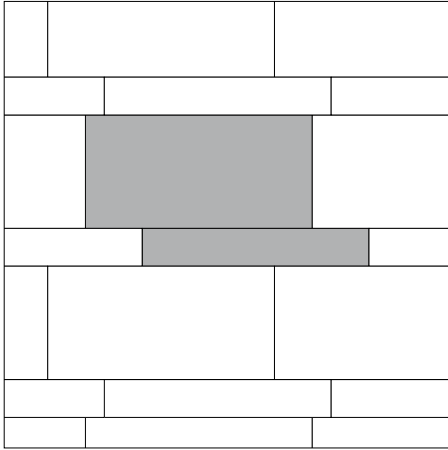

75x150/30"x60" 75%  
25x150/10"x60" 25%

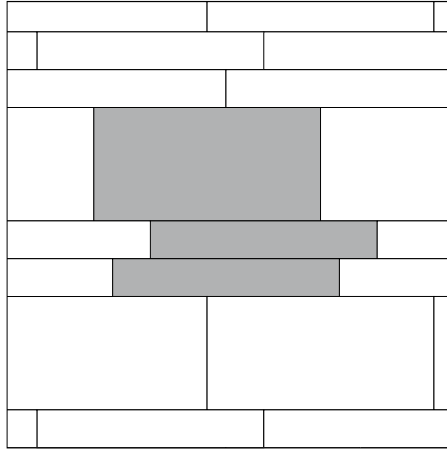

75x150/30"x60" 60%  
25x150/10"x60" 40%

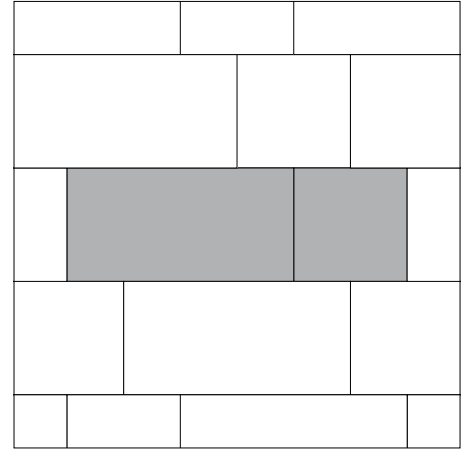

75x150/30"x60" 66,6%  
75x75/30"x30" 33,4%

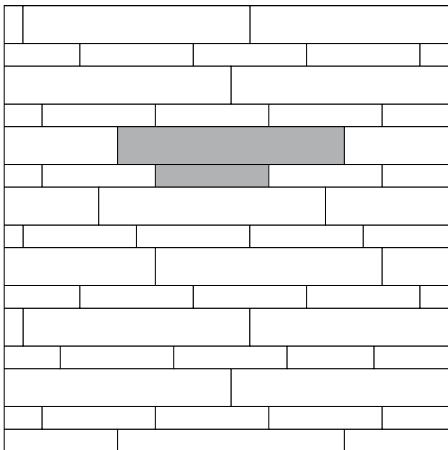

25x150/10"x60" 77%  
15x75/6"x30" 23%

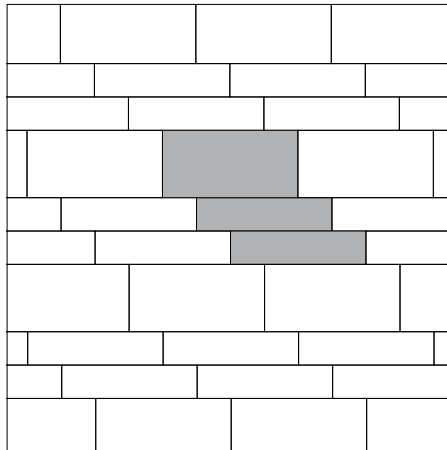

45x90/18"x36" 50%  
22,5x90/9"x36" 50%

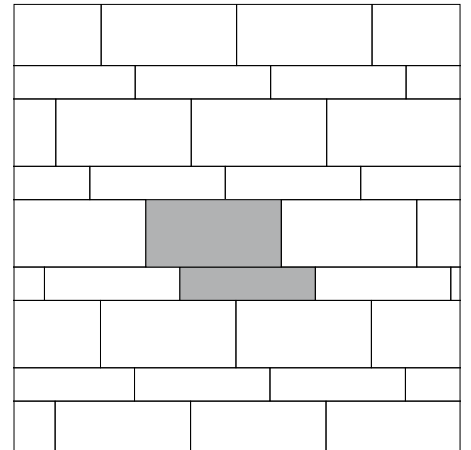

45x90/18"x36" 66,6%  
22,5x90/9"x36" 33,4%

Schemi di posa/Laying  
sketches/Schémas de pose/  
Modulverlegungsbeispiele/  
Legschema/Esquemas  
de colocación

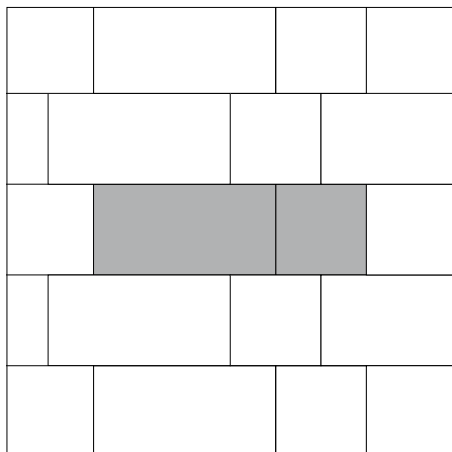

60x120/24"x48"  
60x60/24"x24"

66,6%  
33,4%

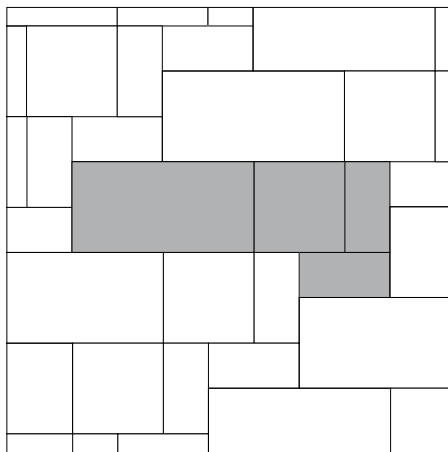

60x120/24"x48"  
60x60/24"x24"  
30x60/12"x24"

50%  
25%  
25%

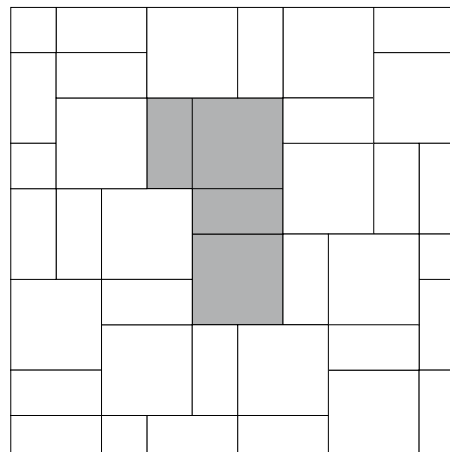

60x60/24"x24"  
30x60/12"x24"

66,7%  
33,3%

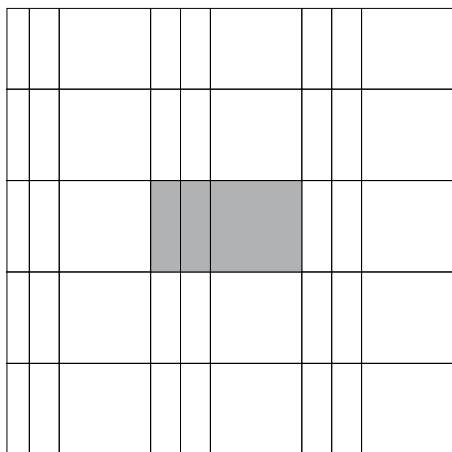

60x60/24"x24"  
20x60/8"x24"

60%  
40%

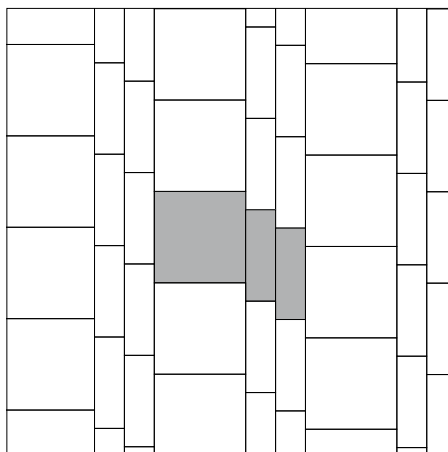

60x60/24"x24"  
20x60/8"x24"

60%  
40%

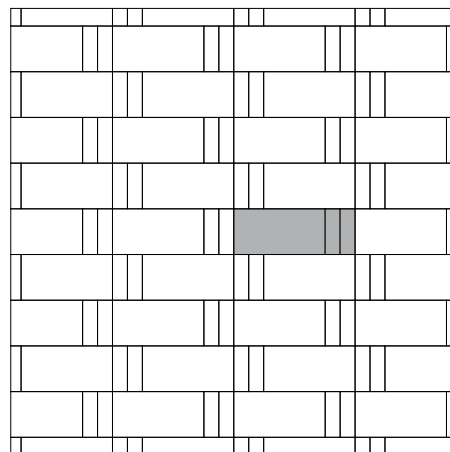

30x60/12"x24"  
10x30/4"x12"

75%  
25%

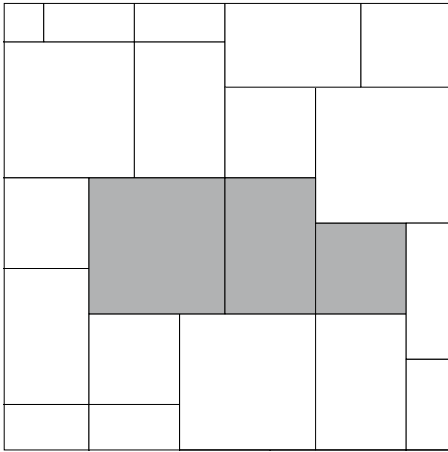

90x90/36"x36" OUT2.0 47,5%  
60x90/24"x36" OUT2.0 21%  
60x60/24"x24" OUT2.0 31,5%

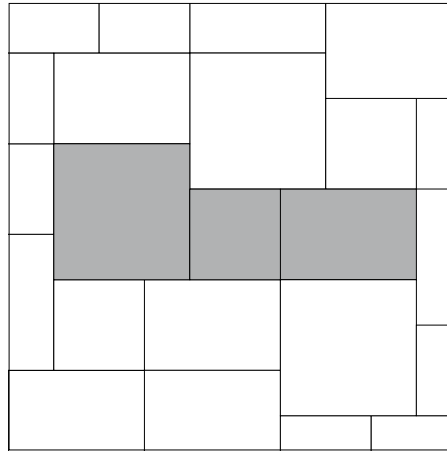

90x90/36"x36" OUT2.0 47,5%  
60x90/24"x36" OUT2.0 21%  
60x60/24"x24" OUT2.0 31,5%

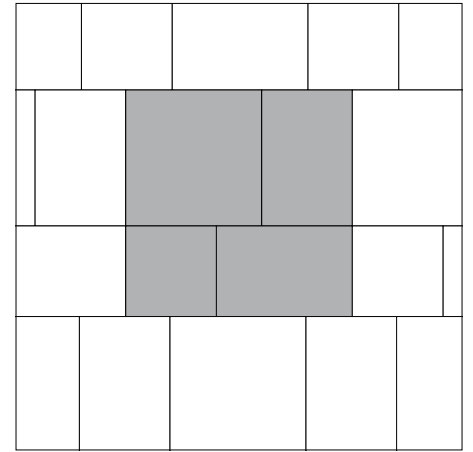

90x90/36"x36" OUT2.0 36%  
60x90/24"x36" OUT2.0 48%  
60x60/24"x24" OUT2.0 16%

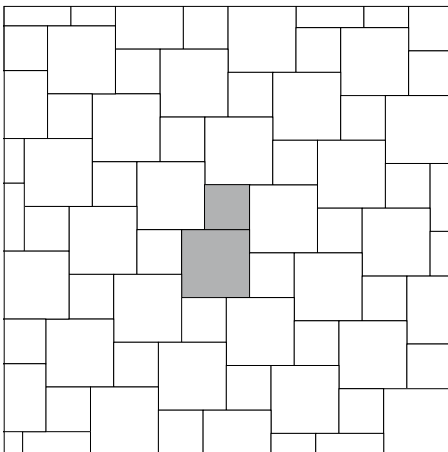

45x45/18"x18" 69%  
30x30/12"x12" 31%



# **Installation and maintenance**

**406/407**



# Manuale di posa e manutenzione

## INTRODUZIONE

L'uso sempre più diffuso del grès porcellanato, contraddistinto da elevate caratteristiche tecniche ed estetiche e destinato ad ambienti commerciali e residenziali, richiede una sempre maggiore attenzione alle modalità di posa e pulizia per ottenere i risultati migliori.

Le piastrelle in grès porcellanato di moderna concezione hanno adottato ormai le lavorazioni tipiche dei prodotti lapidei (rettifica, lappatura, levigatura) portando a pose definite a "fuga minima".

L'uso di pezzi speciali (listelli, doghe, tagli a idrogetto) o l'uso della posa a "formato multiplo" complicano la posa dei pavimenti.

REFIN ritiene pertanto utile ricordare alcune regole fondamentali che sono da applicarsi alle piastrelle in grès porcellanato.

## POSA

**È innanzi tutto doveroso controllare la merce al ricevimento della stessa verificando:**

- Corrispondenza fra documenti di consegna e merce
- Tono, calibro, scelta del materiale.
- Presenza di eventuali difetti

**Si ricorda a tal proposito che non verranno accettate contestazioni per vizi palesi su piastrelle poste in opera** (vedere Condizioni Generali di Vendita a pagina 424)

Le piastrelle in grès porcellanato REFIN sono caratterizzate da un bassissimo assorbimento d'acqua (inferiore a 0,2 %) ed è quindi necessario utilizzare collanti specifici e di alta qualità ed è fortemente sconsigliata in ogni caso la posa tradizionale su caldana cementizia.

Utilizzare quindi solamente collanti migliorati minimo in classe C2 per pavimento, C2 T per rivestimenti e C2 S1-S2 per pavimenti con massetto riscaldante, secondo la EN 12004 che distingue le classi dei collanti come sotto riportato:

### NATURA CHIMICA:

- **C** = Adesivi cementizi
- **D** = Adesivi dispersione
- **R** = Adesivi reattivi

### CLASSE DI ADERENZA:

- **1** = Aderenza normale
- **2** = Aderenza migliorata

### CARATTERISTICHE OPZIONALI:

- **E** = Tempo aperto prolungato
- **F** = Rapidità di posa
- **T** = Resistente allo scivolamento verticale
- **S1** = Adesivo cementizio deformabile
- **S2** = Adesivo cementizio altamente deformabile

La posa tradizionale a malta cementizia non garantisce, per il grès porcellanato, una adeguata adesione delle piastrelle. **Refin non accetta contestazioni per materiale posato senza l'uso di massetto e adesivi adeguati.**

Il massetto di posa deve essere perfettamente planare. Le norme UNI 11493 e ISO 8976-1:1989 prevedono una tolleranza di +/- 3mm sotto una staggia di 2m. In caso di massetto che superi le tolleranze indicate, è consigliabile l'uso di malte

autolivellanti. È contrario alla buona pratica compensare le imperfezioni del piano di posa con lo spessore della colla.



Il piano di posa (massetto) deve essere integro senza crepe, di buona qualità (no polvere), maturo (no ritiri residui) con parametri di resistenza meccanica a flessione adeguati all'utilizzo del pavimento.

Indicativamente i parametri di resistenza possono identificarsi in:

- 10-15 N/mm<sup>2</sup> per ambienti residenziali
- 30 N/mm<sup>2</sup> per ambienti commerciali

Per la resistenza a sforzi paralleli al piano di posa per rivestimenti, tenere un valore R di resistenza 0,8 - 1,2 N/mm<sup>2</sup>

Importante tenere conto, in funzione delle condizioni d'uso, della resistenza a flessione delle piastrelle.

Per lastre di grande formato o per usi particolarmente gravosi (commerciali, industriali) è consigliabile adottare la tecnica della doppia spalmatura di colla per garantire un letto di colla pieno e senza "vuoti" che possono essere fonte di rotture localizzate per flessione o urto.

È buona norma comunque attenersi alle indicazioni dei produttori di materiali per massetti e collanti e ricordare che la posa con adesivi cementizi deve essere effettuata a temperature ambientali comprese fra +5°C e 35°C.

È buona norma, specialmente per materiali con indice di stonizzazione da V2 e superiori prelevare le piastrelle da più scatole contemporaneamente.

Specialmente per i materiali lappati, è opportuno non segnare le tracce dei tagli con pennarelli indelebili o matite a grafite.

## POSA DELLE GRANDI LASTRE

Ai consigli di posa generali del grès porcellanato sopra citati, si aggiungono alcune indicazioni alle quali è necessario attenersi per la messa in opera di piastrelle di grande formato (120x278, 120x240, 120x120, 75x150, 25x150, 60x120) in quanto le prescrizioni per i materiali di formato "normale" diventano più stringenti per le grandi lastre.

- È di fondamentale importanza verificare la perfetta planarità del fondo. Nel caso il fondo non fosse planare, occorre usare una malta autolivellante.

- La posa **deve** essere effettuata con doppia spalmatura dei collanti, su piastrelle e su massetto. In certe situazioni può essere necessario utilizzare colle a tempo aperto prolungato (E) e per il rivestimento colle con elevata resistenza allo scivolamento verticale (T).

- Possono essere effettuate anche installazioni a spalmatura singola nel caso si utilizzino colle ad elevata bagnabilità.

- Per i formati rettangolari sono fortemente sconsigliate pose a correre con sfalsatura superiore al 25%-30%

- È consigliato l'uso di sistemi di autolivellamento per piastrelle

- Si consiglia di impiegare due operatori per la movimentazione e la posa del materiale di formato 120x278, 120x240, 120x120, 75x150 e superiori e di adeguati mezzi per la movimentazione in cantiere

- Devono essere rispettati i giunti di dilatazione (perimetrali e di frazionamento).

- Posare con fuga di minimo 2 mm al fine di compensare eventuali imperfezioni dimensionali in termini di planarità e abbassare il modulo di elasticità del sistema pavimento/rivestimento.

**IMPORTANTE: sulle scatole vengono riportate informazioni sulle piastrelle e prescrizioni per la posa per cui è buona norma prenderne visione prima della posa stessa.**

**Per la posa in facciate, specialmente per facciate in esterno, è consigliabile stendere un capitolo di posa redatto in collaborazione con aziende del settore specializzate (vedi a titolo esemplificativo: KERAKOLL, MAPEI)**

## GIUNTI E STUCCATURE

La rifinitura detta di **rettifica** ha portato a produrre piastrelle di misura estremamente precisa assimilabile al "calibro unico" per cui il consumatore finale è portato spesso a chiedere posa a "giunto minimo" o addirittura senza fuga

Refin prescrive per la posa di piastrelle in **grès porcellanato** rettificato una **fuga minima di 2mm** al fine di compensare le tolleranze di lavorazione derivanti dalla piastrella, dal massetto, dalla posa.

**I materiali naturali (non rettificati)** sono soggetti a tolleranze dimensionali più ampie e le rispettive misure sono riportate sulla tabella calibri presenti nelle scatole per cui la dimensione delle fughe deve essere **almeno di 5 mm.**

**Refin non accetta contestazioni per posa di materiale rettificato con fuga inferiore a 2mm.**

È possibile utilizzare stucchi con pigmenti colorati ma è preferibile, specialmente per prodotti rustici, con superfici rugose e lappate, eseguire una prova preliminare di pulibilità. È comunque necessario effettuare una pulizia del pavimento immediatamente dopo la stuccatura.

È sconsigliabile utilizzare stucature con pigmenti colorati in contrasto con il colore delle piastrelle (esempio: pavimento bianco con fuga marrone o antracite) in pavimenti naturali, mentre la pratica è assolutamente da evitare in pavimenti lappati.

È consigliabile in fase di stuccatura dei lappati l'uso di impermeabilizzanti temporanei prima dell'operazione di fugatura stessa. (tipo ISOL FUGA)

Per superfici di grande estensione sono necessari giunti di dilatazione ogni 25 mq circa per posa all'interno e 20 mq per posa in esterno e devono essere sempre rispettati i giunti di frazionamento del massetto.

Il giunto perimetrale fra muri e pavimenti è necessario per qualsiasi estensione di superficie.

In caso di pavimenti sottoposti a carichi elevati (Industriale) o calpestio frequente (commerciale) è consigliabile l'uso di giunti prefabbricati rinforzati.

## MANUTENZIONE ORDINARIA E STRAORDINARIA

### PULIZIA DI FINE CANTIERE

Per la pulizia a posa ultimata, non è assolutamente

sufficiente lavare il pavimento con sola acqua ed è assolutamente sconsigliabile l'uso di sostanze quali nafta, aceto ecc...

Occorre, invece, procedere ad una pulizia con detergenti a base acida specifici per rimuovere i residui calcarei di boiaccia e di stucchi i cui residui catalizzano lo sporco e sono in grado di trattenerlo formando un "film" sulla superficie che falsa l'aspetto delle piastrelle e forma aloni a contatto con l'acqua (effetto goccioline) o sostanze alimentari che reagiscono con essa.

La situazione ideale, dopo una prima pulizia di sgrassatura, è di attendere il consolidamento degli stucchi e applicare, secondo le istruzioni della casa, i detergenti specifici.

Dopo la pulizia a base di acido tamponato risciacquare abbondantemente per togliere ogni residuo di detergente acido che potrebbe lasciare untuosità sulla superficie (se necessario usare un detergente sgrassante) o danneggiare la superficie.

È consigliabile comunque effettuare una prova su un campione di superficie e successivamente, in caso di esito positivo, agire su tutto il pavimento. Il suddetto accorgimento è necessario per superfici lucide e lappate sulle quali occorre utilizzare panni o strumenti non abrasivi.

Per la pulizia di fine cantiere delle superfici appena installate si suggerisce l'utilizzo di detergenti specifici in base al tipo di stucco utilizzato per la fuga delle piastrelle, come illustrato nella tabella a pagina 420-421.

## PULIZIA ORDINARIA E STRAORDINARIA

### CONSIGLI DI CARATTERE GENERALE

Le piastrelle Refin sono prodotte conformemente alle norme ISO 10545, EN14411, ISO13006 per cui nei riguardi della resistenza alle macchie sono conformi alla norma 10545-14 (vedi caratteristiche tecniche) che prevede la resistenza ad alcuni tipi di sostanze rappresentative e per un determinato periodo di permanenza della macchia. È quindi consigliabile pulire il più presto possibile le piastrelle specialmente da macchie particolari (inchiostro, vomito, urina, vernici eccetera) e da macchie non comprese nelle sostanze di prova ISO tipo macchie da gomma (tacco delle scarpe), metalli, sangue eccetera...

In ogni caso REFIN declina ogni responsabilità per macchie di sporco garantendo solamente la rispondenza alle norme ISO 10545-14 (RESISTENZA ALLE MACCHIE) e ISO 10545-13 (RESISTENZA AD ACIDI E BASI).

La superficie dei gres porcellanati REFIN è completamente greificata e compatta; l'assorbimento superficiale è ai livelli minimi (al di sotto dello 0,2%) per cui si possono utilizzare detergenti aggressivi senza problemi particolari nel rispetto delle istruzioni della casa fornitrice del prodotto.

Eventuali trattamenti che si volessero effettuare dopo la posa devono essere preceduti da una prova preventiva in quanto, come detto, il gres porcellanato non necessita di interventi post posa.

**Refin non si assume responsabilità per trattamenti effettuati post posa.**

Le precauzioni e l'accuratezza della pulizia devono essere maggiori in ambienti ad alto traffico.

### MANUTENZIONE ORDINARIA

È fondamentale accertarsi che il posatore abbia

operato una pulizia con prodotti specifici per la rimozione dei residui di posa.

Per la manutenzione ordinaria non occorrono operazioni particolari se non l'uso di acqua e di detergenti neutri. Evitare l'uso di prodotti additivati (profumi, cere, tensioattivi, trattamenti chimici ecc) che possono rimanere sulla superficie e quindi alterare sia l'aspetto estetico sia la funzionalità della superficie, rendendo più difficile la pulizia o alterando le proprietà antiscivolo.

Per macchie particolarmente evidenti o difficili si possono utilizzare detergenti più aggressivi, più o meno diluiti, a seconda della tipologia di sporco da trattare.

**È comunque buona norma ricordare che prodotti a base di acido fluoridrico (HF) e derivati danneggiano irrimediabilmente la superficie ceramica.**

Per macchie particolari o aggressive si consiglia l'uso di detergenti specifici ma in ogni caso si consiglia di eliminare in breve tempo l'eventuale macchia in quanto, pur essendo la superficie del gres porcellanato ad assorbimento quasi nullo, la micro rugosità, comunque presente su ogni materiale, può rendere l'operazione di pulizia più difficile mentre un'azione rapida permette normalmente un risultato immediato.

In ogni caso i detergenti indicati nella tabella a pagina 420-421 possono essere utilizzati per i prodotti lappati avendo l'accortezza di non prolungare eccessivamente i tempi di contatto, rispettare le diluizioni e risciacquare. Rimane comunque valido il consiglio di testare preventivamente il prodotto su una piastrella non posata o su una zona ristretta del pavimento.

### MANUTENZIONE STRAORDINARIA E SMACCHIATURA.

La manutenzione straordinaria è un intervento da fare solo al verificarsi di macchie o alonature di varia natura non eliminabili con la comune manutenzione ordinaria.

La loro rimozione si ottiene attraverso l'utilizzo di un detergente specifico nel caso di sporco diffuso sull'intera superficie, oppure, nel caso di macchie localizzate o residui limitati, si può procedere utilizzando uno smacchiatore. La rimozione avviene attraverso una reazione chimica fra la macchia ed il detergente, per cui, a seconda della natura dello sporco, occorre intervenire utilizzando prodotti di diversa tipologia, come illustrato nella tabella a pagina 420-421.

### PULIZIA QUOTIDIANA E MANUTENZIONE PERIODICA

L'utilizzo di prodotti specifici per la pulizia di tutti i giorni del gres porcellanato contribuisce in maniera significativa al mantenimento nel tempo della sua bellezza e funzionalità. Queste soluzioni si utilizzano mediante i tradizionali sistemi di lavaggio (spazzolone e straccio o mocio) e non richiedono risciacquo.

I prodotti consigliati per la pulizia di fine cantiere e le pulizie ordinarie o straordinarie sono riepilogate nella tabella a pagina 420-421.

# Installation and maintenance manual

## INTRODUCTION

The increasingly widespread use of porcelain stoneware, distinguished by high technical and aesthetic characteristics and intended for commercial and residential environments, requires extra attention during installation and cleaning to get the best results.

Modern porcelain stoneware tiles have adopted the typical processes of stone products (rectifying, lapping, polishing) leading to layouts with "minimal joints".

The use of special pieces (strips, slats, waterjet cuts) or the use of "multiple format" layouts complicates the laying of floors.

REFIN therefore considers it useful to underline some basic rules that apply to porcelain stoneware tiles.

## LAYING

**First of all it is necessary to inspect the goods upon receipt, checking:**

- Correspondence between delivery documents and goods.
- Colour, size, choice of material
- Presence of any defects

**In this regard, remember that no claims will be accepted for visible defects of already installed tiles** (see General Conditions of Sale on page 426)

REFIN porcelain stoneware tiles have a very low level of water absorption (less than 0.2%) and it is therefore necessary to use specific and high-quality glues, and in any case traditional laying on concrete slabs is strongly discouraged.

Therefore, use only improved adhesives having a minimum class of C2 for the floor, C2 T for walls and C2 S1-S2 for floors with heating screed, according to EN 12004 which distinguishes the classes of adhesives as shown below:

### CHEMICAL NATURE:

- **C** = Cementitious adhesives
- **D** = Dispersion adhesives
- **R** = Reaction resin adhesives

### ADHESIVE CLASS:

- **1** = Normal adhesive
- **2** = Improved adhesive

### OPTIONAL CHARACTERISTICS:

- **E** = Extended open time
- **F** = Fast setting
- **T** = Reduced vertical slip
- **S1** = Deformable cementitious adhesive
- **S2** = Highly deformable cementitious adhesive

For porcelain stoneware, traditional laying with cement mortar does not guarantee an adequate adhesion of the tiles. **Refin does not accept claims for material laid without the use of suitable screed and adhesives.**

The laying screed must be perfectly flat. The UNI 11493 and ISO 8976-1:1989 standards provide for a tolerance of +/- 3 mm under a 2 m straight edge. In case of a screed that exceeds the indicated tolerances, it is advisable to use self-levelling mortars. It is not good practice to use the thickness of the glue to compensate for imperfec-

tions in the laying surface.

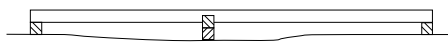

The laying surface (screed) must be intact without cracks, of good quality (no dust), mature (no residual shrinkage) with parameters of mechanical flexing strength suited to the use of the flooring. Roughly speaking, the strength parameters should be:

- 10-15 N/mm<sup>2</sup> for residential spaces
- 30 N/mm<sup>2</sup> for commercial spaces

For resistance to stresses parallel to the laying surface of wall tiles, maintain a resistance R value of 0.8 - 1.2 N/mm<sup>2</sup>

Depending on the conditions of use, it is important to take into account the flex strength of the tiles.

For large format slabs or for particularly high traffic (commercial, industrial) it is advisable to use the double buttering technique to guarantee a full bed of glue without any empty spaces that can lead to breakage due to bending or impact.

In any case, it is good practice to follow the instructions of the producers of the materials for screeds and adhesives and remember that the installation with cementitious adhesives must be carried out at ambient temperatures between +5°C and 35°C.

It is a good idea - especially for materials with a V2 shading index and above - to pick the tiles from several boxes at the same time.

Especially for lapped materials, it is advisable not to mark cuts using indelible felt pens or graphite pencils.

### LAYING OF LARGE TILES

In addition to the general suggestions above for laying porcelain stoneware, further care is required when working with large format tiles (120x278, 120x240, 120x120, 75x150, 25x150, 60x120 cm) as the instructions for the materials of "normal" format become more strict for large slabs.

- It is essential to verify the perfect flatness of the substrate. If the substrate is not flat, it is necessary to use a self-levelling mortar

- The laying must be done with double buttering of the glues, both on the tiles and on the screed. In certain situations it may be necessary to use glues with extended open time (E) and high resistance to vertical slipping (T).

- Single-coating installations can also be carried out if glues with high wettability are used.

- For rectangular formats, layouts with staggering above 25%-30% are strongly discouraged

- The use of self-levelling systems for tiles is recommended

- It is recommended to use two people to handle and lay tiles measuring 120x278, 120x240, 120x120, 75x150 and above and employ adequate transport for moving the slabs in the work site.

- Expansion joints - (perimeter and fractioning) - must be used

- Lay with a minimum joint of 2 mm in order to compensate for any dimensional imperfections in

terms of flatness and lower the modulus of elasticity of the floor/wall system.

**IMPORTANT: the boxes include information on the tiles and laying instructions that you should read before laying.**

**For installation on façades, especially outdoors, it is advisable to prepare installation specifications together with companies specialised in the sector (see, for example: KERAKOLL, MAPEI)**

### JOINTS AND GROUT

**Rectifying** has made it possible to produce extremely precise tiles that can be considered similar to a "standard size", so final consumers often ask for a "minimum joint" or even without any joint at all. Refin prescribes a **minimum joint of 2 mm** for the laying of **rectified porcelain stoneware** tiles in order to compensate the working tolerances in the tile, the screed and the laying.

**Natural (unrectified)** materials are subject to larger dimensional tolerances, and the respective measurements are shown on the size table on the boxes, so the size of the joints must be **at least 5 mm**.

**Refin does not accept claims for laying of rectified materials with a joint of less than 2 mm.**

It is possible to use grout with coloured pigments but it is best - especially for rustic products, with rough and lapped surfaces - to perform a preliminary cleaning test. In any case, it is necessary to clean the floor immediately after grouting.

It is not recommended to use grouts with coloured pigments that contrast with the colour of the tiles (example: white floor with brown or dark grey joint) in natural floors, while this should absolutely be avoided with lapped floors.

The use of temporary waterproofing before the grouting operation (like ISOL FUGA) is recommended during the grouting of polished products.

For large surfaces, expansion joints are required every 25 square metres for indoor installation and 20 square metres for outdoor installation, and the screed expansion joints must always be respected.

The perimeter joint between walls and floors is necessary for any surface.

In the case of floors subjected to high loads (industrial) or foot traffic (commercial) it is advisable to use reinforced prefabricated joints.

## ORDINARY AND EXTRAORDINARY MAINTENANCE

### END-OF-JOB CLEANING

For cleaning when the installation is finished, it is not sufficient to wash the floor with water alone, and it is absolutely inadvisable to use substances like fuel oil, vinegar, etc.

Instead, it is **necessary** to clean using specific acid-based detergents to remove the chalky and grout residues that capture the dirt and are able to retain it forming a film on the surface that distorts the appearance of the tiles and rings in water (droplet effect) or food substances that react with it. The ideal situation, after a first rough cleaning, is to wait for the grout to harden and apply specific detergents following the manufacturer's instructions.

After cleaning with buffered acid, rinse thoroughly

to remove any residual acid detergent that may leave greasiness on the surface (if necessary use a degreasing detergent) or damage the surface. However, it is advisable to carry out a test on a sample of the surface and then, if the result is positive, proceed with the entire floor.

The aforementioned expedient is necessary for polished and lapped surfaces, on which non-abrasive cloths or tools should be used.

For the purpose of cleaning the newly installed surfaces at the end of installation it is suggested to use specific detergents based on the type of grout used in the joints, as shown in table on page 420-421.

## ORDINARY AND EXTRAORDINARY CLEANING

### GENERAL ADVICE

Refin tiles are produced in compliance with ISO 10545, EN14411, ISO13006 standards, so they are resistant to stains as per ISO 10545-14 (see technical specifications) which provides resistance to some representative substances and for a certain period of permanence of the stain. It is therefore advisable to clean the tiles as soon as possible, especially particular stains (ink, vomit, urine, paints, etc.) and stains not included in the ISO test substances, like rubber (shoe heel), metals, blood etc.

In any case, REFIN does not accept any responsibility for stains, guaranteeing only compliance with ISO 10545-14 (RESISTANCE TO STAINS) and ISO 10545-13 (RESISTANCE TO ACIDS AND BASES) standards.

The surface of REFIN porcelain stoneware is completely glazed and compact. Surface absorption is at minimum levels (below 0.2%) so aggressive detergents can be used without particular problems if the manufacturer's instructions are followed.

Any treatments that should be carried out after laying must be preceded by a test since, as mentioned, porcelain stoneware does not require any actions after installation.

**Refin assumes no responsibility for treatments made after installation.**

Precautions and cleaning accuracy must be greater in high traffic environments.

### ORDINARY MAINTENANCE

It is essential to make sure that the installer has cleaned using specific products for the removal of laying residues.

For routine maintenance, no special operation is required other than the use of water and mild detergents. Avoid the use of additives (perfumes, waxes, surfactants, chemical treatments, etc.) that can remain on the surface and therefore alter both the appearance and the performance of the surface, making cleaning more difficult or altering the anti-slip properties.

For particularly visible or difficult stains you can use more aggressive detergents, more or less diluted, depending on the type of dirt to be removed.

**However, it is good practice to remember that products based on fluoridic acid (HF) and its derivatives irreparably damage the ceramic surface.**

For particular or aggressive stains we recommend

the use of specific detergents, but in any case it is advisable to eliminate any stains quickly because while the porcelain stoneware surface is practically non-absorbent, the micro roughness that is present on all tiles can make the cleaning more difficult, and quick action normally allows for an immediate result.

In any case, the detergents indicated in table on page 420-421 can be used for lapped products, taking care to avoid prolonged contact, respect the dilutions and rinse. All the same, it is always best to test the product beforehand on a tile that has not been laid or in a small area of the floor.

### EXTRAORDINARY MAINTENANCE AND STAIN REMOVAL

Extraordinary maintenance is an operation to be carried out only when there are stains or rings of various kinds that cannot be eliminated with ordinary routine maintenance.

These can be removed using a specific detergent in the event of widespread dirt on the entire surface, or for localised spots or residues it is possible to use a stain remover. Removal occurs through a chemical reaction between the stain and the detergent, so that, depending on the nature of the dirt, it is necessary to employ different types of products, as shown in table on page 420-421.

### DAILY CLEANING AND PERIODIC MAINTENANCE

The use of specific products for the daily cleaning of porcelain stoneware contributes significantly to the maintenance of its beauty and performance over time. These solutions are used through traditional washing systems (brush and rag or mop) and do not require rinsing.

The products recommended for end-of-job cleaning and ordinary or extraordinary cleaning are summarised in table on page 420-421.

# Manuel de pose et d'entretien

## INTRODUCTION

L'utilisation de plus en plus répandue du grès cérame, caractérisé par de hautes caractéristiques techniques et esthétiques, et destiné aux espaces commerciaux et résidentiels, exige une plus grande attention aux modalités de pose et d'entretien afin d'obtenir les meilleurs résultats.

Les carreaux en grès cérame de conception moderne ont désormais adopté les façonnages typiques des produits en pierre (rectifiés, polis, poncés), en conduisant à des poses définies à "joint minimum".

L'utilisation de pièces spéciales (listels, lames, découpe par hydrojet) ou l'utilisation d'une pose à "format multiple" compliquent la pose du carrelage au sol.

REFIN pense ainsi qu'il est utile de rappeler quelques règles fondamentales qu'il faut appliquer aux carreaux en grès cérame.

## POSE

**Il faut d'abord dûment contrôler la marchandise lors de la réception, en vérifiant:**

- La correspondance entre la marchandise et les documents de livraison
- Coloris, dimension, composition du matériel
- Présence d'éventuels défauts

**Nous rappelons à ce sujet que toute réclamation sur des vices évidents de carreaux déjà posés ne saurait être acceptée** (voir les conditions générales de vente page 428)

Les carreaux en grès cérame REFIN étant caractérisés par un très bas taux d'absorption d'eau (inférieur à 0,2 %), il faut utiliser des colles spécifiques de haute qualité, et il est vivement déconseillé d'effectuer une pose traditionnelle sur un mortier isolant à base de ciment.

Il faut ainsi utiliser uniquement des colles améliorées d'une classe minimum C2 pour les sols, de classe C2 T pour les murs et de classe C2 S1-S2 pour les sols à chape chauffante, selon la norme EN 12004 qui distingue les classes de colles comme indiqué ci-dessous :

### NATURE CHIMIQUE:

- **C** = Adhésifs à base de ciment
- **D** = Adhésifs dispersion
- **R** = Adhésifs réactifs

### CLASSE D'ADHÉRENCE:

- **1** = Adhérence normale
- **2** = Adhérence améliorée

### CARACTÉRISTIQUES OPTIONNELLES:

- **E** = Temps ouvert prolongé
- **F** = Rapidité de pose
- **T** = Résistance au glissement vertical
- **S1** = Adhésif déformable à base de ciment
- **S2** = Adhésif hautement déformable à base de ciment

La pose traditionnelle à base de mortier de ciment du grès cérame ne garantit pas l'adhérence adéquate des carreaux. **Refin ne pourra accepter aucune réclamation sur du matériel posé sans l'utilisation d'enduits ou d'adhésifs appropriés.**

L'enduit de pose doit être parfaitement plan. Les normes UNI 11493 et ISO 8976-1:1989 prévoient une tolérance de planéité de +/- 3 mm sous la règle de 2 m. En cas d'enduit dépassant les tolérances indiquées, il est conseillé d'utiliser des mortiers autonivelants. Il est contraire à la bonne pratique de compenser les imperfections du plan de pose par l'épaisseur de la colle.



Le plan de pose (enduit) doit être intègre et sans fissure, de bonne qualité (sans poussière), sec (aucun retrait résiduel), et avec des paramètres de résistance mécanique à la flexion appropriés à l'usage du sol.

À titre indicatif, les paramètres de résistance peuvent être définis comme suit :

- 10-15 N/mm<sup>2</sup> pour les espaces résidentiels
- 30 N/mm<sup>2</sup> pour les espaces commerciaux

Pour la résistance aux efforts parallèles d'un plan de pose mural, considérer une valeur de résistance R de l'ordre de 0,8 - 1,2 N/mm<sup>2</sup>

Il est important de tenir compte, en fonction des conditions d'utilisation, de la résistance à la flexion des carreaux.

Pour les dalles de grand format ou pour des utilisations particulièrement lourdes (usages commercial et industriel), il est conseillé d'adopter la technique du double encollage pour garantir un lit de colle plein et sans "vide", ceci pour éviter toute source de rupture localisée par choc ou flexion. Il est de bonne règle de respecter également les indications des fabricants de colles et d'enduits, et de se rappeler que la pose effectuée avec des adhésifs à base de ciment doit être réalisée à une température ambiante comprise entre +5 °C et 35 °C.

Il est de bonne règle, notamment pour les matériaux ayant un indice de dénuancement V2 et supérieur, de prélever les carreaux à partir de plusieurs boîtes à la fois.

En particulier, il est opportun de ne pas marquer les traces de découpe sur les matériaux polis en utilisant des feutres indélébiles ou des crayons à mine graphite.

## POSE DE GRANDES DALLES

Outre les conseils généraux illustrés plus haut sur la pose du grès cérame, nous ajoutons des indications qu'il faut respecter pour la pose de carreaux de grand format (120x278, 120x240, 120x120, 75x150, 25x150, 60x120 cm), car les prescriptions fournies pour le matériel au format "normal" sont encore plus impératives pour les dalles de grande taille.

- Il est extrêmement important de vérifier la parfaite planéité de la couche de fond. Si la couche de fond n'est pas parfaitement plane, il faut utiliser un mortier autonivelant

- La pose **doit** être effectuée par double encollage, tant sur les carreaux que sur l'enduit. Dans certains cas, il peut s'avérer nécessaire d'utiliser des colles à temps ouvert prolongé (E) ainsi que des colles à haute résistance au glissement vertical (T)

pour le carrelage mural.

- Il est également possible de faire une pose à simple encollage en cas d'utilisation de colles à haut pouvoir mouillant.

- Pour les formats rectangulaires, il est vivement déconseillé de faire une pose en enfilade en réalisant un décalage supérieur à 25%-30%

- Il est conseillé d'utiliser des systèmes autonivelants pour les carrelages

- Il est conseillé d'employer deux opérateurs pour la manutention et la pose du matériel de format 120x278, 120x240, 120x120, 75x150 et supérieurs, et d'utiliser des moyens de levage adéquats sur le chantier

- Il faut respecter les joints de dilatation (périmétraux et de fractionnement)

- Effectuer la pose avec un jointolement minimum de 2 mm afin de compenser d'éventuelles imperfections dimensionnelles en termes de planéité, et diminuer le module d'élasticité du système sol/mur.

**IMPORTANT: les boîtes reportent des informations sur les carreaux et des prescriptions concernant la pose. Il est de bonne règle de les consulter avant d'effectuer la pose.**

**Pour la pose sur des façades extérieures, il est conseillé de rédiger un cahier des charges de la pose avec la collaboration d'entreprises spécialisées du secteur (voir à titre d'exemple: KERA-KOLL, MAPEI)**

## JOINTS ET JOINTOIEMENTS

La finition dite rectifiée a porté à fabriquer des carreaux de mesure extrêmement précise, assimilable à une "dimension unique", ce qui conduit souvent le consommateur à demander une pose à "joint minimum", voire sans jointolement

Pour la pose de carreaux en grès cérame **rectifié**, Refin prescrit un **joint minimum de 2 mm** afin de compenser les tolérances de façonnage dérivant du carreau, de l'enduit et de la pose.

Le matériel **naturel (non rectifié)** est soumis à de plus grandes tolérances dimensionnelles dont les mesures respectives sont indiquées sur le tableau des dimensions qui est placé sur les boîtes. La dimension des jointolements doit être **d'au moins 5 mm**.

**Refin ne saurait accepter des réclamations sur la pose d'un matériel rectifié dont le jointolement serait inférieur à 2 mm.**

Il est possible d'utiliser des joints à pigment colorés mais il est préférable d'effectuer un essai préliminaire de nettoyage, notamment pour les produits rustiques et aux surfaces polies ou rugueuses. Il est néanmoins nécessaire de procéder au nettoyage du sol immédiatement après le jointolement.

Il est déconseillé d'utiliser des jointolements à pigment coloré, dont la couleur serait en contraste par rapport à celle du carreau (exemple : sol blanc avec jointolement gris ou ocre) pour des sols naturels, tandis que cette pratique doit être absolument évitée sur des sols dont le carrelage présente une finition polie.

Pendant la phase de jointolement de carreaux polis, il est conseillé d'utiliser des imperméabilisants temporaires avant d'effectuer l'opération de jointolement (type ISOL FUGA).

Pour les grandes surfaces, il faut utiliser des joints de dilatation environ tous les 25 m<sup>2</sup> pour une pose

en intérieur, et tous les 20 m<sup>2</sup> pour une pose en extérieur. Il faut aussi toujours respecter les joints de fractionnement de l'enduit.

Le joint périmétral entre le mur et le sol est nécessaire sur toute l'extension de la surface.

En cas de sols soumis à des charges élevées (sol industriel) ou à un trafic fréquent (sol commercial), il est conseillé d'utiliser des joints renforcés préfabriqués.

## ENTRETIEN ORDINAIRE ET EXTRAORDINAIRE

### NETTOYAGE EN FIN DE CHANTIER

Une fois la pose terminée, il ne suffit pas de nettoyer le sol avec de l'eau, et il est absolument déconseillé d'utiliser des substances telles que naphta, vinaigre, etc...

Au contraire, il faut procéder à un nettoyage avec des produits à base acide, spécifiques pour l'élimination des résidus calcaires de coulis et de joints, dont les résidus catalysent la saleté et sont en mesure de la retenir en formant un "film" sur la surface qui fausse l'aspect des carreaux et qui forme des auréoles au contact de l'eau (effet gouttelettes) ou substances alimentaires réagissant à leur contact.

Après un premier nettoyage de dégrossissage, le mieux est d'attendre le durcissement des mortiers-collés et d'appliquer les produits nettoyants spécifiques en suivant les instructions des fabricants.

Après le nettoyage à base d'acide tamponné, rincer à grande eau pour éliminer tout résidu de nettoyant acide qui pourrait endommager la surface ou y laisser des traces graisseuses (au besoin, utiliser un produit dégraissant).

Il est toujours conseillé d'effectuer un essai sur un échantillon de carrelage, puis en cas de résultat positif, d'intervenir sur l'ensemble du sol. Cette précaution est **nécessaire** pour les surfaces brillantes et polies, sur lesquelles il faut utiliser des chiffons ou des outils non abrasifs.

Pour le nettoyage de fin de chantier des carrelages à peine posés, nous conseillons d'utiliser des produits nettoyants spécifiques en fonction du type de mortier-colle utilisé pour le jointoiment des carreaux, comme illustré sur le tableau page 420-421.

### NETTOYAGE ORDINAIRE ET EXTRAORDINAIRE

#### CONSEILS DE CARACTÈRE GÉNÉRAL

Les carreaux Refin sont fabriqués en conformité aux normes ISO 10545, EN 14411 et ISO 13006, partant en ce qui concerne la résistance aux taches, ils sont conformes à la norme ISO 10545-14 (voir les caractéristiques techniques) qui prévoit la résistance à certains types de substances représentatives pour une durée déterminée de permanence de la tache. Il est donc conseillé de nettoyer les carreaux le plus rapidement possible, en éliminant notamment les taches particulières (encre, vomissement, urine, peintures, etc...), ainsi que les taches non comprises dans les substances d'essai type de l'ISO, par exemple les taches de caoutchouc (talon de chaussures), métaux, sang, etc...

REFIN décline toute responsabilité pour les taches

de saleté en garantissant uniquement la correspondance aux normes ISO 10545-14 (RÉSISTANCE AUX TACHES) et ISO 10545-13 (RÉSISTANCE AUX BASES ET AUX ACIDES).

La surface des carrelages en grès cérame REFIN est entièrement grésée et compacte ; l'absorption superficielle présente un taux minimum (sous 0,2%), il est ainsi possible d'utiliser des produits nettoyants agressifs sans problème particulier, sous réserve de respecter les instructions fournies par le fabricant du produit.

Tout éventuel traitement qui serait effectué après la pose doit être précédé par un essai préventif, car comme déjà indiqué, le grès cérame ne nécessite d'aucune intervention après la pose.

**Refin décline toute responsabilité pour des traitements effectués après la pose.**

Il faut redoubler de soin et de précautions apporté au nettoyage dans les espaces à fort trafic.

#### ENTRETIEN ORDINAIRE

Il est fondamental de vérifier que le poseur ait effectué le nettoyage avec des produits spécifiques pour l'élimination des résidus de pose. Pour l'entretien ordinaire, aucune opération particulière n'est nécessaire, sauf l'utilisation d'eau et de nettoyants neutres. Éviter l'utilisation de produits à base d'additifs (parfums, cires, tensioactifs, traitements chimiques, etc...) qui peuvent rester sur la surface et altérer tant l'aspect esthétique que la fonctionnalité de la surface, en rendant plus difficile le nettoyage ou en altérant les propriétés anti-glissade.

Pour des taches particulièrement évidentes ou difficiles à éliminer, il est possible d'utiliser des produits nettoyants plus agressifs, plus ou moins dilués, selon la typologie de la salissure à traiter.

**Il est de bonne règle de se rappeler que les produits à base d'acide fluorhydrique (HF) et dérivés endommagent la surface céramique de manière irrémédiable.**

Pour des taches particulières ou agressives, nous conseillons d'utiliser des produits nettoyants spécifiques. Il est toujours recommandé d'éliminer rapidement toutes taches, car quoique la surface du grès cérame présente une absorption quasi nulle, la microrugosité présente sur chaque matériel peut rendre l'opération de nettoyage plus difficile, tandis qu'une action rapide offre normalement un résultat immédiat.

Dans tous les cas, les produits nettoyants indiqués sur le tableau page 420-421. peuvent être utilisés pour les produits polis, en ayant soin de ne pas prolonger excessivement le temps de contact, de respecter les dilutions et de bien rincer. Il est toujours conseillé de tester préliminairement le produit sur un carreau non posé ou sur une zone limitée du sol.

#### ENTRETIEN EXTRAORDINAIRE ET ÉLIMINATION DES TACHES

L'entretien extraordinaire est une intervention à n'effectuer qu'en cas de taches ou d'auréoles de diverses natures, qu'un entretien ordinaire ne permet pas d'éliminer.

Leur élimination s'effectue en utilisant un produit nettoyant spécifique en cas de salissure sur toute la surface. En cas de taches localisées ou de résidus limités, il est possible de procéder en utilisant un produit détachant. L'élimination s'effectue à travers une réaction chimique entre la tache et le pro-

duit nettoyant, c'est pourquoi il faut intervenir en utilisant différents types de produits en fonction de la nature de la tache, comme illustré sur le tableau page 420-421.

#### NETTOYAGE QUOTIDIEN ET ENTRETIEN PÉRIODIQUE

L'utilisation de produits spécifiques pour le nettoyage quotidien du grès cérame contribue de manière significative au maintien durable de son esthétique et de sa fonctionnalité. Ces solutions sont utilisées avec les systèmes traditionnels de lavage (brosses et chiffon ou serpillère) et n'exigent aucun rinçage.

Les produits de nettoyage conseillés à utiliser en fin de chantier, ainsi que les opérations de nettoyage ordinaire ou extraordinaire, sont résumés sur le tableau page 420-421.

# Handbuch für die Verlegung und pflege

## EINLEITUNG

Die immer stärkere Verbreitung des Feinsteinzeugs das seit jeher für seine sehr guten technischen und optischen Eigenschaften geschätzt wird und im Gewerbe- wie im Wohnungsbau zum Einsatz kommt, erfordert besondere Aufmerksamkeit bei der Verlegung und Reinigung, wenn beste Ergebnisse erzielt werden sollen.

Moderne Steinzeugfliesen werden heute ebenso bearbeitet wie Naturstein (Rektifizierung, Läppung, Schliff), was die Verlegung mit „minimaler Fuge“ erlaubt.

Der Einsatz von Formstücken (Leisten, Dielen, mit Wasserstrahl geschnittene Teile) bzw. die gleichzeitige Verlegung mehrerer Formate stellen besondere Anforderungen an die Verlegung von Bodenfliesen.

REFIN hat daher einige Grundregeln für Fliesen aus Feinsteinzeug zusammengestellt.

## VERLEGUNG

**Zunächst ist die Ware bei Erhalt auf Folgendes zu prüfen:**

- Entsprechung von Frachtpapieren und Ware
- Farbton, Kaliber, Sortierung des Materials
- Vorhandensein eventueller Mängel

**Wir weisen darauf hin, dass Reklamationen sichtbarer Mängel an bereits verlegten Fliesen nicht akzeptiert werden** (siehe die Allgemeinen Geschäftsbedingungen, Seite 430)

Die Steinzeugfliesen von REFIN zeichnen sich durch eine extrem geringe Wasseraufnahme aus (unter 0,2 %). Deshalb müssen Spezialkleber von hoher Qualität verwendet werden. Von der traditionellen Verlegung mit Zementmörtel wird dringend abgeraten.

Verwenden Sie daher nur vergütete Kleber der Klasse C2 für die Verlegung am Boden, C2 T an der Wand und C2 S1-S2 auf Böden mit Fußbodenheizung nach EN 12004, in der die Kleber in folgende Klassen unterteilt sind:

### CHEMISCHE BESCHAFFENHEIT:

- C = Zementkleber
- D = Dispersionskleber
- R = Reaktionskleber

### HAFTKRAFTKLASSE:

- 1 = normale Haftung
- 2 = verbesserte Haftung

### ZUSÄTZLICHE MERKMALE:

- E = längere klebeoffene Zeit
- F = schnelle Verlegung
- T = abrutschfest
- S1 = Verformbarer Zementkleber
- S2 = Hochverformbarer Zementkleber

Bei traditioneller Verlegung von Steinzeug mit Zementmörtel ist ein korrektes Anhaften der Fliesen nicht gewährleistet. **Refin akzeptiert bei ungeeignetem Estrich und Kleber keine Reklamationen von verlegtem Material.**

Der Verlegeuntergrund muss absolut eben sein. Die Richtlinien UNI 11493 und ISO 8976-1:1989 verlangen über eine 2 m lange Richtlatte eine Toleranz von +/- 3 mm. Überschreitet der Estrich die

angegebene Toleranz, so sollte selbstnivellierender Mörtel aufgebracht werden. Unvollkommenheiten des Verlegeuntergrunds sollten nicht durch mehr oder weniger dicken Auftrag des Klebers ausgeglichen werden.



Die Verlegefläche (Estrich) muss unversehrt und rissfrei, von guter Qualität (staubfrei) und reif (Schwindung abgeschlossen) sein, und die mechanische Biegefestigkeit muss der beabsichtigten Verwendung des Bodens angemessen sein. Zur Orientierung können folgende Beständigkeitsparameter gelten:

- 10-15 N/mm<sup>2</sup> für Wohnräume
- 30 N/mm<sup>2</sup> für Gewerberäume

Für die Beständigkeit gegen parallel zur Verlegefläche verlaufende Belastungen bei Wandverkleidungen ist ein Beständigkeitswert R 0,8 - 1,2 N/mm<sup>2</sup> einzuhalten.

Je nach Anwendungsbedingungen ist die Biegefestigkeit der Fliesen zu berücksichtigen.

Für großformatige Platten bzw. bei besonders hoher Beanspruchung (Verkaufsflächen, Industrie...) sollte der Kleber beidseitig aufgetragen werden, um ein volles Klebbett ohne „Hohlstellen“ zu garantieren, denn Letztere können bei Biegung oder Stößen Ursache von Brüchen sein. In jedem Fall sind die Hinweise der Estrich- und Kleberhersteller zu beachten; zudem muss die Verlegung mit Zementklebern bei einer Raumtemperatur zwischen +5 °C und 35 °C erfolgen. Insbesondere bei Materialien mit Farbabweichungsgrad V2 und darüber sollten stets Fliesen aus mehreren Schachteln zugleich verlegt werden. Vor allem bei geläppter Material sind Schnitte nicht mit Permanent- oder Grafitstiften anzureißen.

### VERLEGUNG GROSSER PLATTEN

Neben den generellen Empfehlungen für die Verlegung von Steinzeug sind bei der Verlegung großformatiger Fliesen (120x278, 120x240, 120x120, 75x150, 25x150, 60x120 cm) einige weitere Hinweise zu beachten, da die für „normale Formate“ geltenden Vorschriften für große Platten noch strenger werden.

- Es ist von entscheidender Bedeutung, die perfekte Ebenheit des Untergrunds sicherzustellen. Ist der Untergrund nicht plan, so muss ein selbstnivellierender Mörtel aufgebracht werden.
- Die Verlegung muss mit beidseitig, das heißt sowohl auf die Fliesenrückseite als auch auf den Estrich aufgetragenem Kleber erfolgen. Bestimmte Situationen können die Verwendung von Kleber mit verlängerter klebeoffener Zeit (E) sowie bei der Verlegung von Wandverkleidungen Kleber mit hoher Abrutschfestigkeit (T) erfordern.
- Bei Verwendung von Klebern mit hohem Benetzungsvermögen kann auch der einseitige Auftrag genügen.
- Bei rechteckigen Formaten wird dringend von der um mehr als 25 % bis 30% versetzten Längsverlegung abgeraten.
- Wir empfehlen Selbstnivellierungssysteme für

Fliesen.

- Material in den Formaten 120x278, 120x240, 120x120, 75x150 und größer sollte auf der Baustelle stets zu zweit und unter Einsatz geeigneter Hilfsmittel bewegt und verlegt werden.
- Es sind Dehnungsfugen (am Außenrand entlang sowie zur Segmentierung) auszuführen.
- Zum Ausgleich eventueller Unebenheiten sowie zur Reduzierung des Elastizitätsmoduls des Boden/Wand-Systems sind mindestens 2 mm breite Fugen erforderlich.

**WICHTIG: Auf den Schachteln sind Informationen über die Fliesen sowie Verlegehinweise aufgedruckt. Bitte lesen Sie diese vor der Verlegung durch.**

**Für die Verlegung von Fassaden und insbesondere von Außenfassaden empfiehlt sich die Verfassung von Verlegevorschriften in Zusammenarbeit mit Fachunternehmern (wie, lediglich beispielgebend: KERAKOLL, MAPEI)**

### FUGEN UND VERFUGUNG

Die als Rektifizierung bezeichnete Abschlussbearbeitung führt zu extrem präzisen Fliesenabmessungen, die dem „Einheitskaliber“ gleichgesetzt werden können. Der Endverbraucher wünscht in diesem Fall häufig die Verlegung mit „minimaler Fuge“ bzw. sogar die fugenlose Verlegung. Refin schreibt für die Verlegung von **rektifizierten Steinzeugfliesen eine mindestens 2 mm breite Fuge** vor, um Verarbeitungstoleranzen von Fliese, Estrich und Verlegung auszugleichen.

**Naturbelassene, nicht rektifizierte** Materialien unterliegen größeren Maßtoleranzen; ihre jeweiligen Abmessungen sind in der den Schachteln inliegenden Kalibertabelle aufgeführt. In diesem Fall müssen die Fugen **wenigstens 5 mm** breit sein.

**Refin akzeptiert keine Reklamationen von rektifiziertem Material, das mit weniger als 2 mm breiten Fugen verlegt wurde.**

Die Verwendung von farbigen Fugenmassen ist möglich; es ist jedoch - insbesondere für rustikale Materialien mit rauer oder geläppter Oberfläche - vorab zu testen, ob diese sich anschließend gut reinigen lassen. In jedem Fall ist der Bodenbelag sofort nach dem Verfugen zu reinigen.

Von der Verwendung farbiger, mit der Fliesenfarbe kontrastierender Pigmente (zum Beispiel: weißer Bodenbelag mit brauner oder dunkelgrauer Fuge) bei naturbelassenen Bodenbelägen ist abzuraten, während dies bei geläppter Fliesen unbedingt zu vermeiden ist.

Vor dem Verfugen geläppter Fliesen sollte eine vorübergehende Abdichtung aufgebracht werden (z.B. ISOLFUGA).

Auf großen Flächen sind in Innenbereichen etwa alle 25 qm und in Außenbereichen alle 20 qm Dehnungsfugen erforderlich, und die im Estrich vorhandenen Bewegungsfugen sind stets zu übernehmen.

Die Randfuge zwischen Mauer und Bodenbelag ist bei Flächen jeglicher Größe unabdingbar. In starken Belastungen (Industrie) oder häufiger Begehung (Einkaufszentren) ausgesetzten Bodenbelägen sollten vorgefertigte, verstärkte Dehnungsfugen eingesetzt werden.

## NORMALE UND AUSSERORDENTLICHE PFLEGE

### ABSCHLUSSREINIGUNG NACH DER VERLEGUNG

Nach der Verlegung ist es keinesfalls ausreichend, den Bodenbelag nur mit klarem Wasser zu säubern, und Substanzen wie Naphtha, Essig etc. sind absolut zu vermeiden.

Stattdessen ist der Boden mit spezifischen, säurehaltigen Reinigungsmitteln zu säubern, um die kalkhaltigen Rückstände von Schlämme und Fugenmassen zu entfernen. Diese können als Schmutzfänger fungieren und auf der Oberfläche einen „Film“ bilden, der die Optik der Fliesen beeinträchtigt und bei Kontakt mit Wasser zu Schleierbildung führt („Tropfeneffekt“), ebenso wie bei Kontakt mit damit reagierenden Lebensmitteln. Idealerweise sollte nach einer ersten Grobreinigung die Verfestigung der Fugenmasse abgewartet und anschließend je nach Anweisungen des Herstellers Spezialreiniger verwendet werden. Nach der Reinigung mit Puffersäure den Belag mit reichlich Wasser abspülen, um jegliche Rückstände des sauren Reinigungsmittels zu entfernen. Diese könnten Fettspuren auf der Oberfläche hinterlassen (erforderlichenfalls Entfetter verwenden) oder die Oberfläche beschädigen.

In jedem Fall sollte zunächst an einen kleinen Bereich ein Test vorgenommen werden und bei zufriedenstellendem Ergebnis der gesamte Bodenbelag gereinigt werden.

Diese Vorkehrung ist bei glänzenden und geläpften Oberflächen **erforderlich**, und zudem sind nicht abrasive Tücher oder Geräte zu verwenden. Für die Abschlussreinigung frisch verlegter Beläge sollten je nach verwendeter Fugenmasse entsprechende Spezialreiniger verwendet werden, siehe Tabelle auf Seite 420-421.

### NORMALE UND AUSSERORDENTLICHE REINIGUNG

#### ALLGEMEINE EMPFEHLUNGEN

Refin-Fliesen werden nach den Richtlinien ISO 10545, EN14411, ISO13006 hergestellt und entsprechen hinsichtlich der Fleckenbeständigkeit der Richtlinie ISO 10545-14 (siehe technische Merkmale). Diese verlangt die Beständigkeit gegen einige repräsentative Substanzen bei einer bestimmten Verweildauer des Flecks. Die Fliesen sollten daher stets so rasch wie möglich gereinigt werden, vor allem, wenn es sich um Flecken besonderer Art (Tinte, Erbrochenes, Urin, Lack etc.) bzw. um nicht von der ISO-Prüfung erfasste Flecken wie Gummi (Schuhabsätze), Metalle, Blut etc. handelt.

In jedem Fall haftet REFIN nicht für durch Schmutz entstandene Flecken, sondern garantiert lediglich die Konformität mit den Richtlinien ISO 10545-14 (BESTÄNDIGKEIT GEGEN FLECKENBILDNER) UND ISO 10545-13 (CHEMISCHE BESTÄNDIGKEIT). Die Oberfläche des REFIN-Steinzeugs ist voll gesintert und kompakt; die oberflächliche Wasseraufnahme der ist minimal (unter 0,2 %). Daher können bei Beachtung der Herstellerhinweise ohne besondere Probleme aggressive Reinigungsmittel verwendet werden.

Eventuelle Behandlungen nach der Verlegung dürfen erst nach einer vorherigen Probe vorgenommen werden, denn wie erläutert, bedarf das

Steinzeug nach der Verlegung keiner weiteren Behandlungen.

**Refin haftet nicht für nach der Verlegung vorgenommene Behandlungen.**

In stark beanspruchten Bereichen erfordert die Reinigung besondere Umsicht und Gründlichkeit.

#### NORMALE PFLEGE

Es ist sicherzustellen, dass der Fliesenleger die Reinigung mit Spezialprodukten zur Entfernung der Verlegerückstände vorgenommen hat.

Die normale Pflege erfolgt einfach mit Wasser und neutralen Reinigungsmitteln. Mit Zusätzen (Duftmittel, Wachse, Tenside, chemische Behandlungen etc.) versehene Produkte sollten vermieden werden, da diese an der Oberfläche verbleiben und sowohl die Optik als auch die Funktionalität des Belags beeinträchtigen können: Sie können die Reinigung erschweren oder die Rutschfestigkeit reduzieren.

Bei besonders auffälligen oder schwer entfernbaren Flecken können aggressivere, je nach Art der Flecken mehr oder weniger stark verdünnte Reinigungsmittel verwendet werden.

**Es ist zu beachten, dass Produkte mit Flusssäure (HF) und deren Nebenprodukten die keramische Oberfläche irreparabel beschädigen.**

Für besondere bzw. aggressive Flecken sollten Spezialreiniger verwendet werden; in jedem Fall sind die Flecken schnellstmöglich zu entfernen. Auch wenn die Steinzeugoberfläche ein Aufnahmevermögen von nahezu Null hat, kann die an jedem Material vorhandene Mikrorauheit die Reinigung erschweren, während ein schnelles Agieren in der Regel zu sofortigem Erfolg führt. In jedem Fall können die in Tabelle auf Seite 420-421 angegebenen Reinigungsmittel für geläppte Produkte verwendet werden, vorausgesetzt, sie werden nicht zu lange in Kontakt gelassen, vorschriftsgemäß verdünnt und wieder abgespült. Auch hier gilt die Empfehlung, das Produkt vorab an einer nicht verlegten Fliese oder an einem kleinen Bereich des Bodenbelags zu testen.

#### AUSSERORDENTLICHE REINIGUNG UND FLECKENTFERNUNG

Die außerordentliche Reinigung sollte nur durchgeführt werden, wenn sich Flecken oder Schleier mit der normalen Pflege nicht entfernen lassen. Über die gesamte Oberfläche verbreiteter Schmutz kann mit einem Spezialreiniger entfernt werden, und einzelne Flecken oder begrenzte Rückstände mit einem Fleckentferner. Die Entfernung erfolgt durch eine chemische Reaktion zwischen dem Fleck und dem Reinigungsmittel. Deshalb sind je nach Art des Schmutzes unterschiedliche Produkte zu verwenden; siehe Tabelle auf Seite 420-421.

#### TÄGLICHE REINIGUNG UND PERIODISCHE PFLEGE

Die tägliche Reinigung des Steinzeugs mit Spezialprodukten ist ein wichtiger Beitrag zum dauerhaften Erhalt seiner Schönheit und Funktionalität. Diese Lösungen werden mit traditionellen Wischsystemen (Schrubber und Wischtuch oder Wischmopp) verwendet; Nachspülen ist nicht notwendig.

Die für die Abschlussreinigung nach der Verlegung und die normale bzw. außerordentliche Reinigung empfohlenen Produkte sind Tabelle auf Seite 420-

421 zu entnehmen.



# Handleiding voor het leggen en onderhoud

## INLEIDING

Het steeds wijder verbreid gebruik van porselein-gres, dai wordt gekenmerkt door uitstekende technische en esthetische eigenschappen en dat is bedoeld voor commerciële omgevingen en woningen, vereist steeds meer aandacht voor de manier van leggen en reinigen om de beste resultaten te verkrijgen.

De moderne gres procellanato tegels hebben nu de kenmerkende bewerkingen van steenproducten (slijpen, schuren, polijsten) overgenomen, waardoor ze worden gelegd met een "minimale voeg".

Het gebruik van speciale stukken (lijsten, langwerpige tegels, watersnijders) of het gebruik van het "multi-formaat" maakt het leggen van de vloeren moeilijker.

REFIN acht het derhalve nuttig een aantal fundamentele regels te geven die moeten worden toegepast bij gres procellanato tegels.

## HET LEGGEN

### Allereerst moet tijdens de ontvangst van de tegels worden gecontroleerd:

- of de ontvangen tegels overeenstemmen met de verzenddocumenten
- de kleur, de afmeting en de materiaalkeuze
- de aanwezigheid van eventuele gebreken

**Denk er hierbij dat geen reclamaties zullen worden geaccepteerd voor duidelijke gebreken van gelegde tegels** (zie Algemene Verkoopvoorwaarden op pagina 432)

De gres procellanato tegels van REFIN worden gekenmerkt door een zeer lage wateropname (minder dan 0,2%). Daarom moeten speciale lijmen van hoge kwaliteit worden gebruikt en wordt het in ieder geval ten zeerste afgeraden ze volgens de traditie op een betonnen ondervloer te leggen.

Gebruik daarom uitsluitend verbeterde lijm van ten minste klasse C2 voor vloeren, C2 T voor bekledingen en C2 S1-S2 voor vloeren met vloerverwarming, volgens EN 12004 die de lijmklassen als volgt onderscheidt:

### CHEMISCHE AARD:

- C = Cementlijmen
- D = Dispersielijmen
- R = Reactieve lijmen

### HECHTINGKLASSEN:

- 1 = Normale hechting
- 2 = Verbeterde hechting

### OPTIONELE KENMERKEN:

- E = Verlengde open tijd
- F = Leggsnelheid
- T = Weerstand tegen verticale slip
- S1 = Vervormbare cementlijm
- S2 = Sterk vervormbare cementlijm

Wanneer gres procellanato tegels traditioneel met cementmortel worden gelegd garandeert dat geen voldoende hechting van de tegels. **Refin accepteert geen reclamaties voor materiaal dat is gelegd zonder het gebruik van een ondervloer en geschikte lijmen.**

De ondervloer moet perfect waterpas zijn. De normen UNI 11493 en ISO 8976-1:1989 voorzien een tolerantie van +/- 3 mm onder een rei van 2 m. Bij een ondervloer die de opgegeven toleranties overschrijdt is het raadzaam om zelfnivellerende mortels te gebruiken. Het is in strijd met de algemene regels om de onvolkomenheden van het legvlak te compenseren met de dikte van de lijm.



Het legvlak (ondervloer) moet intact zijn, zonder scheuren, van goede kwaliteit (geen stof) en uitgehard zijn (niet meer kunnen krimpen) met een mechanische buigweerstand, die geschikt is voor het gebruik van de vloer.

De weerstandsparementen zijn ongeveer als volgt:

- 10-15 N/mm<sup>2</sup> voor woningen
- 30 N/mm<sup>2</sup> voor winkels

Voor de weerstand tegen belasting parallel aan het legvlak van de tegels moet een R-waarde worden aangehouden van 0,8 - 1,2 N/mm<sup>2</sup>.

Het is afhankelijk van de gebruiksomstandigheden belangrijk om rekening te houden met de buigsterkte van de tegels.

Voor tegels met grote afmetingen of bij bijzonder zware gebruiksomstandigheden (commercieel, industrieel) is het raadzaam om de techniek van de dubbele lijmlaag toe te passen om een volle lijmlaag te garanderen zonder "lege plekken", die er de oorzaak van kunnen zijn dat tegels door doorbuigen of stoten gelokaliseerd breken.

Het is een goede gewoonte zich altijd aan de aanwijzingen van de fabrikanten van materialen voor ondervloeren en lijm te houden en er altijd aan te denken dat wanneer de tegels met cementlijmen worden gelegd dit altijd moet gebeuren bij omgevingstemperaturen tussen de +5°C en 35°C. Het is vooral bij materialen met een kleurindex van V2 en hoger een goede gewoonte om de tegels uit meerdere dozen tegelijk te nemen.

Vooraf bij de geschuurde materialen is het raadzaam de snijlijn niet met onuitwisbare stiften of grafietpotloden aan te geven.

## GROTE TEGELS LEGGEN

Naast de hierboven gegeven aanbevelingen voor het leggen van gres procellanato tegels zijn er ook enkele aanwijzingen waaraan men zich moet houden bij het leggen van grote tegels (120x278, 120x240, 120x120, 75x150, 25x150, 60x120 cm), aangezien de voorschriften voor de materialen met een "normaal" formaat strenger zijn bij grote tegels.

- Het is van fundamenteel belang om te controleren of de bodem perfect waterpas is. Indien de bodem niet perfect waterpas is, moet een zelfnivellerende mortel worden gebruikt.

- De tegels **moeten** worden gelegd met een dubbele lijmlaag, op de tegels en op de ondervloer. In bepaalde situaties kan het nodig zijn om lijm te gebruiken met een lange open tijd (E) en voor de bekleding lijm met een hoge weerstand tegen verticale slip (T).

- Tegels kunnen ook met een enkele lijmlaag wor-

den gelegd wanneer lijm met hoge bevochtigbaarheid wordt gebruikt.

- Het wordt bij rechthoekige formaten sterk afgeraden voor een rechte legging te kiezen waarbij de tegels meer dan 25-30% verspringen

- Het wordt aanbevolen zelfnivellerende systemen voor tegels te gebruiken

- Het wordt aangeraden de tegels met een formaat van 120x278, 120x240, 120x120, 75x150 en groter met zijn tweeën te verplaatsen en te leggen en geschikte middelen te gebruiken om ze op de bouwplaats te verplaatsen

- Zorg voor uitzetvoegen (rondom en fractioneringsvoegen)

- Leg de tegels met een voeg van minstens 2 mm om eventuele maatafwijkingen in de vlakheid te compenseren en verlaag de elasticiteitsmodulus van het vloer/ tegelsysteem

**BELANGRIJK: op de dozen staat informatie over de tegels en voorschriften voor het leggen. Het is dus een goede gewoonte deze te lezen voordat de tegels worden gelegd.**

**Om tegels op gevels te zetten en dan vooral buitengevels is het raadzaam om in samenwerking met gespecialiseerde bedrijven uit de sector voorschriften op te stellen (zie voorbeeld: KERAKOLL, MAPEI)**

## VOEGEN EN STUKEN

De zogenaamde "slijpafwerking" heeft geleid tot de productie van tegels met een uiterst nauwkeurige afmeting, die vergelijkbaar is met "gerectificeerde tegels", waardoor de eindverbruiker vaak geneigd is om te vragen om een "minimale voeg" of de tegels zelfs zonder voeg te leggen.

Refin schrijft bij het leggen van **geslepen gres porcellanato** tegels een **minimumvoeg van 2 mm** voor om de bewerkingstoleranties te compenseren, die voortkomen uit de tegel, de ondervloer en het leggen.

De **natuurlijke (ongeslepen)** materialen zijn onderhevig aan grotere maattoleranties en de bijbehorende maten staan in de afmetingentabel in de dozen. De voegen moeten dus minstens **5 mm** bedragen.

**Refin accepteert geen reclamaties wanneer geslepen materiaal is gelegd met een voeg die kleiner is dan 2 mm.**

Er kunnen gekleurde voegmiddelen worden gebruikt, maar het verdient de voorkeur om bij rustieke producten met ruwe en geschuurde oppervlakken een voorafgaande reinigingstest te verrichten. De vloer moet hoe dan ook onmiddellijk na het voegen schoon worden gemaakt.

Het wordt bij natuurlijke vloeren afgeraden gekleurde voegmiddelen te gebruiken die contrasteren met de kleur van de tegels (bijvoorbeeld: een witte vloer met een bruine of antracietkleurige voeg), terwijl dit bij geschuurde vloeren absoluut moet worden vermeden.

Het is tijdens het voegen van de geschuurde tegels raadzaam om tijdelijk waterafstotende producten te gebruiken (type ISOL FUGA).

Bij grote oppervlakken zijn om de ongeveer 25 m<sup>2</sup> uitzetvoegen nodig wanneer de tegels binnenshuis zijn gelegd en om de ongeveer 20 m<sup>2</sup> wanneer ze buiten zijn gelegd. De fractioneringsvoegen van de ondervloer moeten hierbij altijd in acht worden genomen.

De voeg om de omtrek tussen wanden en vloeren

is noodzakelijk voor elke uitbreiding van het oppervlak.

Bij vloeren die onderhevig zijn aan zware belasting (industriële vloeren) of waar veel over wordt gelopen (commerciële vloeren) is het raadzaam versterkte geprefabriceerde voegen te gebruiken.

## GEWOON en BUITENGEWOON ONDERHOUD

### REINIGING NADAT DE BOUWPLAATS IS OPGEHEVEN

Om de vloer te reinigen nadat de tegels zijn gelegd is het absoluut niet voldoende om de vloer alleen met water te reinigen en wordt beslist afgeraden producten te gebruiken zoals dieselolie, azijn, enz...

In plaats daarvan moet worden gereinigd met zuurhoudende reinigingsmiddelen die speciaal bestemd zijn om resten voegmortel en voegmiddelen te verwijderen, waarvan de resten het vuil katalyseren en kunnen vasthouden door een "laagje" op het oppervlak te vormen dat het aanzien van de tegels verandert en waardoor bij contact met water kringen ontstaan (druppel-effect) of effect van voedingsmiddelen die ermee reageren. De ideale situatie is om na een eerste grove reiniging te wachten tot de voegmiddelen gehard zijn en vervolgens volgens de instructies van de fabrikant specifieke reinigingsmiddelen te gebruiken. Na de reiniging met gebufferd zuur spoelt u het oppervlak grondig af om alle resten zuur reinigingsmiddel te verwijderen dat vet kan achterlaten (gebruik indien nodig een ontvettingsmiddel) of het oppervlak kan beschadigen.

Het is echter raadzaam om een test op een oppervlaktemonster te verrichten en bij een positief resultaat de hele vloer te behandelen.

Bovenbeschreven handelwijze is nodig bij glanzende en geschuurde oppervlakken waarvoor niet schurende doeken of hulpmiddelen moeten worden gebruikt.

Voor de reiniging nadat de tegels pas zijn gelegd wordt aangeraden specifieke reinigingsmiddelen te gebruiken op grond van het soort voegmiddel dat is gebruikt voor de voegen van de tegels, zoals wordt toegelicht in tabel op pagina 420-421.

## GEWOON EN BUITENGEWOON ONDERHOUD

### ALGEMEEN ADVIES

De tegels van Refin zijn geproduceerd volgens de normen ISO 10545, EN14411, ISO13006, dus voor wat betreft de vlekbestendigheid voldoen ze aan de norm ISO 10545-14 (zie de technische kenmerken) die de weerstand voorschrijft tegen enkele representatieve soorten stoffen en gedurende een bepaalde periode waarin de vlek aanwezig is. Het is daarom raadzaam de tegels zo snel mogelijk te reinigen en met name ze te ontdoen van bepaalde vlekken (inkt, braaksel, urine, verf, enz.) en van vlekken die niet zijn opgenomen in de ISO-teststoffen, zoals rubbervlekken (schoenhakken), metalen, bloed, enz 420-421.

REFIN wijst in ieder geval elke verantwoordelijkheid af voor vuilvlekken en garandeert alleen de naleving van de normen ISO 10545-14 (VLEKBESTENDIGHEID) en ISO 10545-13 (WEERSTAND TEGEN ZUREN EN BASEN).

Het oppervlak van de gres porcellanato tegels van REFIN is volledig gesinterd en compact. De oppervlakteabsorptie is minimaal (minder dan 0,2%), waardoor in overeenstemming met de instructies van de leverancier van het product zonder bijzondere problemen agressieve reinigingsmiddelen kunnen worden gebruikt.

Eventuele behandelingen die u na het leggen wilt verrichten moeten worden voorafgegaan door een test, aangezien er bij gres porcellanato geen bewerkingen na het leggen nodig zijn.

**Refin neemt geen verantwoordelijkheid voor behandelingen die na het leggen worden verricht.**

In omgevingen met veel verkeer moeten meer voorzorgsmaatregelen worden getroffen en de reiniging zorgvuldiger zijn.

### GEWOON ONDERHOUD

Het is van fundamenteel belang dat de tegellegger de tegels heeft gereinigd met producten die speciaal bedoeld zijn voor het verwijderen van de resten die bij het leggen zijn ontstaan.

Bij het gewone onderhoud zijn geen speciale handelingen nodig, maar alleen het gebruik van water en neutrale reinigingsmiddelen. Gebruik geen additieven (parfums, was, oppervlakte-actieve stoffen, chemische behandelingen, enz.) die op het oppervlak kunnen achterblijven en dus zowel het aanzien als de functionaliteit van het oppervlak kunnen veranderen, waardoor het reinigen wordt bemoeilijkt of de antislip eigenschappen worden aangetast.

Bij bijzonder duidelijke of moeilijke vlekken kunnen, afhankelijk van het te behandelen soort vuil, agressievere reinigingsmiddelen worden gebruikt, die min of meer verdund zijn.

**Het is in ieder geval goed eraan te denken dat de producten op basis van fluorwaterstofzuur (HF) en derivaten het keramische oppervlak onherstelbaar beschadigen.**

Bij bijzondere of agressieve vlekken adviseren we het gebruik van specifieke reinigingsmiddelen aan. Het is in ieder geval raadzaam om de eventuele vlek binnen korte tijd te verwijderen, omdat, ook al neemt het oppervlak van gres porcellanato vrijwel niets op, de micro ruwheid die hoe dan ook bij elk materiaal aanwezig is, de reiniging kan bemoeilijken, terwijl een snelle handeling over het algemeen een onmiddellijk resultaat mogelijk maakt.

In ieder geval kunnen de op pagina 420-421 vermelde reinigingsmiddelen worden gebruikt voor geschuurde producten, waarbij ervoor moet worden gezorgd de contacttijd niet te lang te houden en dat zich aan de verdunningen en het naspoelen wordt gehouden. Het advies om het product vooraf op een niet gelegde tegel of op een klein gedeelte van de vloer te testen blijft in ieder geval.

### BUITENGEWOON ONDERHOUD EN ONTVLEKKEN

Buitengewoon onderhoud moet alleen worden verricht wanneer er vlekken of kringen van verschillende aard zijn ontstaan, die met gewoon onderhoud niet kunnen worden verwijderd.

Ze kunnen worden verwijderd door het gebruik van een specifiek reinigingsmiddel bij over het hele oppervlak verspreid vuil. Bij gelokaliseerde vlekken of beperkte resten kan een ontvlekker worden gebruikt. De verwijdering vindt plaats door middel van een chemische reactie tussen de vlek en het

reinigingsmiddel, en dus moeten afhankelijk van de aard van het vuil verschillende producten worden gebruikt, zoals wordt toegelicht in tabel op pagina 420-421.

### DAGELIJKSE REINIGING EN PERIODIEK ONDERHOUD

Het gebruik van specifieke producten voor de dagelijkse reiniging van gres porcellanato draagt in belangrijke mate bij tot het behoud over lange tijd van de schoonheid en functionaliteit ervan. Deze oplossingen worden gebruikt met traditionele reinigingssystemen (schrobber en dweil of mop) en hoeven niet te worden nagespoeld.

De producten die worden aangeraden nadat de tegels zijn gelegd en de gewone of buitengewone reiniging zijn samengevat in tabel op pagina 420-421.

# Manual de colocación y mantenimiento

## INTRODUCCIÓN

El empleo del gres porcelánico está cada vez más difundido gracias a sus elevadas características técnicas y cualidades estéticas, y destinado a entornos comerciales y residenciales, requieren más y más una mayor atención a los métodos de colocación y limpieza para obtener los mejores resultados.

Las baldosas de gres porcelánico de última generación, han adoptado los procesos típicos de los productos lapídeos (rectificado, lapeado, pulido) requiriendo colocaciones llamadas "junta mínima". El empleo de piezas especiales (listeles, tablas, cortes por chorro de agua) o el uso de colocación en "formato múltiple" dificultan la colocación de los pavimentos.

REFIN considera útil recordarles algunas de las reglas básicas sobre el proceso de aplicación de las baldosas de gres porcelánico.

## COLOCACIÓN

**En primer lugar, al recibir el material y en cualquier caso es necesario comprobar cuidadosamente:**

- Correspondencia entre los documentos de entrega y la mercancía
- Tono, calibre, elección del material
- Presencia de posibles defectos visibles

**A este respecto se recuerda que no se aceptarán reclamaciones por vicios patentes en las baldosas puestas en obra** (véase Condiciones Generales de Venta en la página 434)

Las baldosas de gres porcelánico REFIN se caracterizan por una absorción de agua muy baja (menos del 0,2 %) por consiguiente, es necesario el empleo de materiales de agarre específicos de alta calidad y no es aconsejable en ningún caso la colocación tradicional en alcatifa cementosa.

Por todo ello, hay que utilizar únicamente materiales de agarre mejorados mínimo en clase C2 para pavimento, C2 T para revestimientos y C2 S1-S2 para pavimentos con solera para calefacción por suelo, conforme a EN 12004 que distingue las clases de los materiales de agarre, como aquí indicados:

### SEGÚN SU COMPOSICIÓN QUÍMICA:

- C = Adhesivos cementosos
- D = Adhesivos en dispersión
- R = Adhesivos de reacción

### CLASE DE ADHERENCIA:

- 1 = Adherencia normal
- 2 = Adherencia mejorada

### CARACTERÍSTICAS OPCIONALES:

- E = De largo tiempo abierto
- F = De rápido fraguado
- T = Resistente al deslizamiento vertical
- S1 = Adhesivo cementoso deformable
- S2 = Adhesivo cementoso altamente deformable

La colocación tradicional con mortero de cemento no garantiza, para el gres porcelánico, un adecuado agarre de las baldosas. **Refin no acepta ningún tipo de impugnación por material colo-**

**cado sin haber hecho uso de solera y adhesivos adecuados.**

La solera de la superficie de trabajo tiene que estar perfectamente plana. Las normas UNI 11493 y ISO 8976-1:1989 prevén una tolerancia de +/- 3mm bajo un reglón de 2m. En caso de solera que supere las tolerancias indicadas, se recomienda el uso de mortero autonivelador. Es contrario a las buenas prácticas compensar las imperfecciones de la superficie de colocación con el espesor del material de agarre.

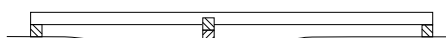

La superficie de colocación (solera) tiene que estar en perfectas condiciones y sin grietas, debe ser de buena calidad (sin polvo), madura (sin contracción residual) que posea los parámetros de resistencia mecánica a la flexión conformes al uso del pavimento.

Indicativamente los parámetros de resistencia se pueden identificar en:

- 10-15 N/mm<sup>2</sup> para ambientes residenciales
- 30 N/mm<sup>2</sup> para ambientes comerciales

Para la resistencia a esfuerzos paralelos a la superficie de colocación, para revestimientos, mantener un valor R de resistencia 0,8 - 1,2 N/mm<sup>2</sup>

En función de las condiciones de uso es importante tener en cuenta la resistencia a flexiones de las baldosas.

Para las placas de formato grande o para usos de alto tránsito peatonal o gravosos (comerciales, industriales) se aconseja adoptar la técnica de doble encolado para garantizar un lecho doble de material de agarre lleno y sin "vacíos" que puedan ser la fuente de roturas localizadas debido a flexión o choque.

Sin embargo, se les recomienda seguir escrupulosamente las instrucciones de los fabricantes de soleras y materiales de agarre y siempre tener en cuenta que la colocación con adhesivos cementosos debe llevarse a cabo a temperatura ambiente entre +5°C y 35°C.

También se aconseja, especialmente para materiales con índice de destonificación de V2 y superiores, colocar el material sacando las piezas de varias cajas para conseguir una óptima mezcla. Para los materiales lapeados, en particular, durante la colocación no deberá marcarse la superficie (trazos para el corte) de utilización con marcadores indelebles o lápices de grafito.

### COLOCACIÓN DE LAS PLACAS GRANDES

A los consejos generales antes indicados para la colocación del gres porcelánico, se añaden otras informaciones importantes a seguir para la colocación de las placas de formato grande (120x278, 120x240, 120x120, 75x150, 25x150, 60x120 cm) ya que los requisitos para los materiales de formato "normal" no son suficientes para las placas grandes.

- Es muy importante controlar que el fondo esté perfectamente plano. Si no está completamente plano, hay que utilizar un mortero autonivelador.

- La colocación **se tiene que efectuar** con doble capa de material de agarre, en las baldosas y en el mortero. A veces es necesario utilizar materiales de agarre de largo tiempo abierto (E) y para el revestimiento emplear materiales de agarre de elevada resistencia al deslizamiento vertical (T).

- Se pueden efectuar instalaciones con la extensión de una sola capa si se utilizan materiales de agarre de elevada mojabilidad.

- Para los formatos rectangulares se desaconseja la colocación alternando las líneas de las juntas que superen el 25%-30%

- Se aconseja el uso de sistemas de auto nivelación para baldosas

- Para el desplazamiento y la colocación del material de tamaño 120x278, 120x240, 120x120, 75x150 y más grandes, se recomienda que esta operación sea realizada por dos personas, y ayudándose con el uso de medios para el desplazamiento en la obra.

- Hay que respetar las juntas de dilatación entre baldosas (perimetrales y de partición)

- Colocar con junta de mínimo 2 mm para compensar cualquier imperfección de tamaño en términos de planeidad y reducir el módulo de elasticidad del sistema pavimento / revestimiento.

**IMPORTANTE: hay que tener en cuenta que en las cajas están imprimidas las informaciones relativas a las baldosas y las indicaciones para la colocación de éstas, se recomienda leer dicha información antes de la colocación.**

**Para la colocación en fachadas, especialmente en fachadas en el exterior, se recomienda redactar un pliego de las especificaciones de colocación en colaboración con empresas especializadas del sector (a título de ejemplo, consultar: KERAKOLL, MAPEI) ecomienda.**

### JUNTAS Y REJUNTADOS

El acabado llamado de rectificación ha dado como resultado la producción de baldosas completamente iguales que se pueden asimilar al "calibre único" por consiguiente, el consumidor final a menudo pide la colocación en "junta mínima" o incluso sin junta.

Para la colocación de las baldosas de **gres porcelánico rectificado** Refin prescribe una **junta mínima de 2mm**, con el objetivo de compensar las tolerancias de trabajo derivadas de las baldosas, de la solera, de la colocación.

Los materiales **naturales (no rectificadas)** están sujetos a tolerancias dimensionales más amplias, cuyas medidas están indicadas en la tabla de los calibres de las cajas, por lo tanto la dimensión de las juntas tiene que ser **almeno de 5 mm**.

**Refin no acepta ningún tipo de impugnación por colocación de material rectificado con junta inferior a 2mm.**

Es posible utilizar materiales de rejuntado con pigmentos colorados, sin embargo, para productos rústicos con superficies rugosas y lapeadas, hay que realizar previamente una prueba real de limpieza. Siempre y de todas maneras es necesario eliminar cuidadosa e inmediatamente el material de rejuntado del pavimento con el fin de reducir el contraste.

No se aconseja utilizar materiales de rejuntado con pigmentos colorados que hagan contraste con el color de las baldosas (ejemplo: pavimento blanco con junta marrón o antracita) en pavimentos naturales; hay que evitar taxativamente esta

práctica en pavimentos lepeados.

En fase de rejuntado de los lepeados, se sugiere utilizar impermeabilizantes provisionales antes de la operación de rejuntado de las juntas (tipo ISOL FUGA).

Para la colocación en superficies de grandes dimensiones, son necesarias juntas de dilatación más o menos cada 25 m<sup>2</sup>, y cada 20 m<sup>2</sup> para colocación en exteriores, y siempre hay que respetar las juntas de partición de la solera.

La junta perimetral entre paredes y pavimentos es necesaria para cualquier extensión de superficie. En caso de pavimentos sometidos a cargas elevadas (industrial) o alto tránsito peatonal (comercial) se aconseja el uso de juntas prefabricadas reforzadas.

## MANTENIMIENTO ORDINARIO Y EXTRAORDINARIO

### LIMPIEZA DE FINALIZACIÓN DE LA OBRA

Tras haber acabado la colocación de las baldosas, nunca llega a ser suficiente lavar el pavimento solo con agua, además por ningún motivo hay que lavarlo utilizando sustancias como nafta, vinagre, etc.

Es necesario llevar a cabo la limpieza con detergentes de base ácida específicos para quitar los restos calcáreos de lechada y de materiales de rejuntado cuyos residuos catalizan la suciedad reteniéndola y formando una "película" en la superficie que falsea el aspecto de las baldosas y forma huellas o halos al contacto con el agua (efecto gota) o sustancias alimenticias que reaccionan con ésta.

La situación ideal, después de la primera limpieza de desbastado, es esperar que el material de rejuntado aplicado se haya secado y adherido completamente, luego aplicar los detergentes específicos según las instrucciones dadas por el fabricante.

Después de la limpieza con ácido tamponado, lavar con abundante agua para quitar todos los residuos de detergente ácido que pudieran dejar untuosidad en la superficie (si es necesario, usar un detergente desgrasante) o dañar la superficie. Se aconseja siempre realizar una prueba real de limpieza en una parte de la superficie y luego, en caso de resultado positivo, intervenir en el resto del pavimento.

La misma precaución es **necesaria** para superficies pulidas y lepeadas en las que se debe utilizar trapos, esponjas o herramientas no abrasivas. Después de finalizar la obra, para limpiar las superficies acabadas de colocar, se aconseja el empleo de detergentes específicos conformes al tipo de material de rejuntado utilizado para las juntas de las baldosas, según indicado en la tabla en la página 420-421.

### LIMPIEZA ORDINARIA Y EXTRAORDINARIA

#### CONSEJOS DE CARÁCTER GENERAL

Las baldosas Refin están fabricadas concordes a las normas ISO 10545, EN 14411, ISO 13006 por ello, respecto a la resistencia a las manchas están conformes a la norma ISO 10545-14 (véanse características técnicas) que prevé la resistencia a algunos tipos de sustancias representativas y por

un cierto período de permanencia de la mancha. Se aconseja siempre limpiar lo antes posible las baldosas de manchas particulares (tinta, vómito, orina, pinturas, etc.) y de manchas no incluidas en las sustancias de prueba ISO, tipo manchas de goma (tacón de los zapatos), metales, sangre, etc.

REFIN declina cualquier responsabilidad por manchas de suciedad garantizando únicamente las que corresponden a las normas ISO 10545-14 (RESISTENCIA A LAS MANCHAS) y ISO 10545-13 (RESISTENCIA A ÁCIDOS Y BASES).

La superficie de los gres porcelánicos REFIN está completamente vitrificada y compacta; la absorción superficial es casi inexistente (por debajo del 0,2%) por consiguiente, se pueden utilizar detergentes agresivos sin particulares problemas respetando las instrucciones del proveedor del producto.

Eventuales procedimientos que se deseen efectuar después de la colocación, tienen que estar precedidos de una prueba de precaución porque, como ya especificado, después de la colocación el gres porcelánico no necesita ningún tipo de tratamiento.

**Refin no se asume responsabilidad alguna por tratamientos efectuados post colocación.**

Las precauciones y el cuidado de la limpieza tienen que ser mayores en ambientes de alto tráfico.

### MANTENIMIENTO ORDINARIO

Es muy importante asegurarse que el instalador haya realizado una limpieza con productos específicos para eliminar los residuos de colocación.

Para el mantenimiento ordinario no son necesarias operaciones particulares, solo hay que utilizar agua y detergentes neutros. Evitar el empleo de productos con aditivos (perfumes, ceras, tensio-activos, tratamientos químicos, etc.) que puedan quedar en la superficie, y por lo consiguiente, cambiar tanto el aspecto estético como la funcionalidad de la superficie, dificultando la limpieza o alterando las propiedades antideslizantes.

Para las manchas persistentes o difíciles, se pueden utilizar detergentes más agresivos, diluidos según el tipo de suciedad a tratar.

**Siempre es una buena norma recordar que los productos a base de ácido fluorhídrico (HF) y sus derivados dañan irremediabilmente la superficie cerámica.**

Para las manchas particulares o agresivas se aconseja utilizar detergentes específicos, y siempre se aconseja eliminar en breve tiempo las eventuales manchas, porque no obstante la superficie del gres porcelánico sea de bajísima absorción, la micro rugosidad presente en cada material puede hacer que la operación de limpieza sea difícil, en cambio una acción rápida permite normalmente un resultado inmediato.

En todo caso los detergentes indicados en la tabla de la página 420-421 se pueden emplear para los productos lepeados teniendo cuidado de no prolongar excesivamente los tiempos de contacto, respetar las diluciones y lavar con abundante agua. Siempre es aconsejable realizar previamente una prueba para probar el producto en una baldosa no colocada o en una zona pequeña del pavimento.

### MANTENIMIENTO EXTRAORDINARIO Y DESMANCHADO

El mantenimiento extraordinario es una operación que se realiza únicamente cuando se verifican manchas o halos de diferente naturaleza y que no es posible eliminarlos con el mantenimiento ordinario.

Para quitar estas manchas se tienen que utilizar detergentes específicos si se trata de suciedad que cubre toda la superficie, o bien, en el caso de manchas localizadas o residuos limitados, se sugiere utilizar un quitamanchas. La eliminación se produce por una reacción química entre la mancha y el detergente, por lo tanto, dependiendo de la naturaleza de la suciedad, es necesario intervenir utilizando productos de diferente tipología, como indicado en la tabla en la página 420-421.

### LIMPIEZA DIARIA Y MANTENIMIENTO PERIÓDICO

La utilización de productos específicos para la limpieza diaria del gres porcelánico, contribuyen de manera significativa a mantener su belleza y funcionalidad a lo largo del tiempo. Estas soluciones se utilizan mediante los tradicionales sistemas de lavado (cepillos, trapos, esponjas o fregonas) y no es necesario lavar con abundante agua.

Los productos aconsejados para la limpieza al final de la obra y la frecuencia de limpieza ordinaria o extraordinaria están resumidas en la tabla en la página 420-421.

# Prodotti per la pulizia/Cleaning products/Produits de nettoyage/ Pflegeprodukten/Reinigungsproducten/Productos para la limpieza

**Pulizia di fine cantiere/End-of-job cleaning/Nettoyage en fin de chantier/Abschlussreinigung nach der verlegung/Reinigung nadat de bouwplaats is opgeheven/Limpieza de finalización de la obra**

Tipologia di stucco utilizzato/Type of grout used/Typologie de mortier-colle utilisé/ Verwendete fugenmasse/Soorten gebruikte voegmiddelen/Tipologia de material de rejuntado utilizado	Prodotto Faber* suggerito/Suggested Faber* product/Produit Faber* conseillé/ Empfohlenes Faber*-produkt/Aanbevolen Faber*-product/Productos Faber* aconsejado
Stucco cementizio/Cementitious grout/Mortier-colle à base de ciment/ Zementfugenmörtel/Cementmortel/Rejuntado cementoso	<b>CEMENT REMOVER</b>
Stucco epossidico/Epoxy grout/Mortier-colle époxy/Epoxy-fugenmasse/Epoxy-specie/Rejuntado epoxidico	<b>EPOXY RESIDUE REMOVER</b>

**Pulizia straordinaria e smacchiatura/Extraordinary maintenance and stain removal/  
Nettoyage extraordinaire et élimination des taches/Ausserordentliche reinigung und fleckentfernung/  
Buitengewoon onderhoud en ontvlecken/Limpieza extraordinaria y desmanchado**

Tipologia di sporco-macchia/Type of dirt-stain/Typologie de tache-salissure/Art der verschmutzung-des flecks/Soort vuil-vlek/Tipología de suciedad-mancha	Prodotto Faber* suggerito/Suggested Faber* product/Produit Faber* conseillé/ Empfohlenes Faber*-produkt/Aanbevolen Faber*-product/Productos Faber* aconsejado
Carbone/Coal/Charbon/Kohle/Kolen/Carbón	<b>CEMENT REMOVER</b> Detergente specifico a base acida/ Specific acid-based detergent/ Nettoyant spécifique à base acide/ Säurehaltiger spezialreiniger/ Specifiek zuurhoudend reinigingsmiddel/ Detergente específico de base ácida
Cemento/Cement/Ciment/Zement/Cement/Cemento	
Efflorescenze calcaree/Calcareous efflorescence/Efflorescences calcaires/ Kalkausblühungen/Kalkachtige efflorescentie/Eflorescencias procedentes de calcáreos	
Malta/Mortar/Mortier/Mörtel/Mortel/Mortero	
Stucco cementizio/Cementitious grout/Mortier-colle à base de ciment/ Zementfugenmörtel/Cementmortel/Rejuntado cementoso	
Stucco colorato/Coloured grout/Mortier-colle coloré/Farbige fugenmasse/ Gekleurd voegmiddel/Rejuntado colorado	
Tempere murali/Wall paint/Peintures murales/Wandfarbe/Muurtempera's/Témperas murales	
Gesso/Plaster/Plâtre/Gips/Pleisterkalk/Yeso	
Patina superficiale/Superficial patina/Patine superficielle/ Belag auf der oberfläche/Oppervlakkige aanslag/Patina superficial	
Segni e residui metallici/Metallic marks and residues/Traces et résidus métalliques/ Metallische spuren und rückstände/Metalen tekens en residuen/Marcas y residuos metálicos	
Sporco ostinato/Stubborn dirt/Salissure persistante/ Hartnäckiger schmutz/Hardnekkig vuil/Suciedad persistente	
Residui da detergenti/Detergent residues/ Résidus de produits nettoyants/ Reinigungsmittelrückstände/Resten van reinigingsmiddelen/Residuos de detergentes	
Orme ed aloni/Footprints and rings/Empreintes et auréoles/ Fußabdrücke und schleier/Sporen en kringen/Huellas y halos	
Ruggine/Rust/Rouille/Rost/Roest/Herrumbre	
Caffè/Coffee/Café/Kaffee/Koffie/Café	
Ketchup/Ketchup/Ketchup/Ketchup/Tomatenketchup/Ketchup	
Vino/Wine/Vin/Wein/Wijn/Vino	
Pennarelli/Markers/Feutres/Filzstift/Viltstiften/Marcadores	
Tintura per capelli/Hair dye/Teinture de cheveux/Haarfärbemittel/Haarverf/Tintas para cabellos	
Gelato/Ice cream/Glace/Eiskrem/Ijs/Helado	<b>COLOURED STAIN REMOVER</b> Smacchiatore/ Stain remover/ Produit détachant/ Fleckentferner/ Vlekkenmiddel/ Quitamenchas
Residui vegetali/Vegetable residues/Résidus végétaux/Pflanzliche abfälle/Plantenresten/Residuos vegetales	

<b>Tipologia di sporco/macchia/Type of dirt/stain/Typologie de tache/salissure/Art der verschmutzung/des flecks/Soort vuil/vlek/Tipologia de suciedad/mancha</b>	<b>Prodotto Faber* suggerito/Suggested Faber* product/Produit Faber* conseillé/ Empfohlenes Faber*-produkt/Aanbevolen Faber*-product/Producto Faber* aconsejado</b>
Urina/Urine/Urine/Urin/Urine/Orina	<b>COLOURED STAIN REMOVER</b> Rimozione macchia/Stain remover/ Élimination de tache/Fleckentfernung/ Vlekkenmiddel/Eliminación de la manch
Vomito/Vomit/Vomissement/Erbrochenes/Braaksel/Vómito	<b>POLISHING CREAM</b> Ripristino lucentezza/Restore gloss/ Rétablissement de la brillance/ Gglanzpolitur/ Glansherstellend/ Recuperación del brillo
Coca Cola/Coca Cola/Coca cola/Coca-cola/Cola/Coca cola	
Olio di Lino/Linseed oil/Huile de lin/Leinöl/Lijnzaadolie/Aceite de linaza	<b>OIL &amp; GREASE REMOVER</b> Detergente specifico a base alcalina/ Specific alkaline-based detergent/ Nettoyant spécifique à base alcaline/ Alkalischer spezialreiniger/ Specifiek alkalisch reinigingsmiddel/ Detergente específico de base alcalina
Grassi animali-vegetali/Animal-vegetable fats/Graisses animales-végétales/Tierische fette/Dierlijke-plantaardige vetten/Grasas animales-vegetales	
Mostarda/Mustard/Moutarde/Senf/Mosterd/Salsa de especias, vinagre y mostaza	
Oli siliconici o meccanici/Silicone or mechanical oils/Huiles mécaniques ou à base de silicone/ Silikon maschinenöle/Siliconen mechanische oliën/Aceites de silicona-mecánicos	
Segni di pneumatico/Tyre marks/Traces de pneu/Reifenspuren/Bandensporen/Marcas de neumáticos	<b>WAX REMOVER</b> Detergente specifico a base alcalina/ Specific alkaline-based detergent/ Nettoyant spécifique à base alcaline/ Alkalischer spezialreiniger/ Specifiek alkalisch reinigingsmiddel/ Detergente específico de base alcalina
Segni di gomma/Rubber marks/Traces de caoutchouc/Gummispuren/Rubbersporen/Marca de caucho	
Cera di candela/Candle wax/Cire de bougie/Kerzenwachs/Kaarsvet/Cera de vela	
Cera protettiva/Protective wax/Cire protectrice/Schutzwachs/Beschermente was/Cera de protección	
Resine/Resins/Résines/Harze/Harsen/Resinas	<b>GRAFFITI REMOVER / EPOXY RESIDUE REMOVER</b>
Smalti/Polishes/Vernis/Glasuren/Nagellak/Esmaltes	
Graffiti/Graffiti/Graphites/Graffitis/Graffiti/Grafitos	<b>SOLVENT STRIPPER</b> Solvente/Solvent/Solvent/ Lösungsmittel/Oplosmiddel/Solvente
Residui di scotch e altri materiali adesivi/Residues of tape and other adhesive materials/ Résidus de scotch et autre matériel adhésif/Rückstände von Klebeband und anderen Klebstoffen/ Taperesten en resten van andere kleefstoffen/Residuos de cinta adhesiva y otros materiales adhesivos	<b>ALKALINE CLEANER</b> Detergente specifico a base alcalina/ Specific alkaline-based detergent/Nettoyant spécifique à base alcaline/Alkalischer spezialreiniger/ Specifiek alkalisch reinigingsmiddel/Detergente específico a base alcalina

**Pulizia quotidiana e manutenzione periodica/Daily cleaning and periodic maintenance/Nettoyage quotidien et entretien périodique/Tägliche reinigung und periodische pflege/Dagelijkse reiniging en periodiek onderhoud/Limpieza diaria y mantenimiento periódico**

	<b>Prodotto Faber* suggerito/Suggested Faber* product/Produit Faber* conseillé/ Empfohlenes Faber*-produkt/Aanbevolen Faber*-product/Producto Faber* aconsejado</b>
Pulizia quotidiana/Daily cleaning/Nettoyage quotidien/Tägliche reinigung/Dagelijkse reiniging/Limpieza diaria	<b>FLOOR CLEANER</b>
Manutenzione periodica/Periodic maintenance/ Entretien périodique/Periodische pflege/Periodiek onderhoud/Mantenimiento periódico	<b>TILE CLEANER</b> 1:9 Diluito/Diluted/Diluë/Verdünnt/Verdunning/Diluido

\* Ceramiche Refin consiglia i prodotti/Ceramiche refin recommends products by/Ceramiche refin conseille les produits/Ceramiche refin empfiehlt die produkte von/Ceramiche refin raadt de producten aan van/Ceramiche refin aconseja los productos faber chimica:  
**FABER CHIMICA:** [faberchimica.com](http://faberchimica.com) \_ T: (+39) 0732.627178

Si riportano comunque per completezza di informazione i riferimenti di altre marche sul mercato: / However, for completeness of information below are the references for other brands on the market: / Pour plus d'informations, nous reportons également les références d'autres marques vendues dans le commerce: / Der vollständigkeit halber seien jedoch auch weitere, im handel befindliche marken genannt: / Voor alle volledigheid worden ook de gegevens van de andere merken op de markt weergegeven: / Para completar la información, les indicamos las referencias de otras marcas que se encuentran en el mercado:

**CHESTERTON:** [chesterton.com](http://chesterton.com) \_ T: (781) 438.7000  
**FILA INDUSTRIA CHIMICA:** [filachim.com](http://filachim.com) \_ T: (+39) 049.9467300  
**GEAL:** [geal-chim.it](http://geal-chim.it) \_ T: (+39) 0574.7503365  
**KERAKOLL:** [kerakollgroup.com](http://kerakollgroup.com) \_ T: (+39) 0536.916511  
**LITHOFIN:** [lithofin.com](http://lithofin.com) \_ T: (+49) 7024.9403-20  
**MAPEI:** [mapei.it](http://mapei.it) \_ T: (+39) 02.376731



# General terms and conditions of sale

422/423



# Condizioni generali di vendita

Rev.1a del 1 Gennaio 2018

## A.- Modalità di conclusione del contratto

**A.1.-** Le presenti Condizioni Generali di Vendita disciplinano ogni contratto di Vendita tra il Venditore e l'Acquirente ed ogni loro modifica o deroga deve essere concordata per iscritto.

**A.2.-** Eventuali offerte, accrediti e/o abbuoni accordati da agenti o da altri intermediari, non sono ritenuti validi se non confermati per iscritto dal Venditore.

**A.3.-** L'Acquirente invia al Venditore, direttamente o per il tramite di agenti, Ordini scritti che devono contenere l'indicazione dei codici dei Prodotti richiesti, delle quantità, del loro prezzo e della destinazione. L'Ordine inviato dall'Acquirente è irrevocabile.

**A.4.-** La Vendita dovrà ritenersi conclusa nel momento in cui: (i) l'Acquirente riceve da parte del Venditore una Conferma scritta via e-mail, fax o altri mezzi telematici, conforme ai termini e alle condizioni dell'Ordine; o (ii) in caso di Conferma inviata dal Venditore contenente condizioni difformi dall'Ordine ricevuto dall'Acquirente quando questi l'accetti per iscritto o comunque non la contesti entro 7 (sette) giorni dalla ricezione; o (iii) in assenza di conferma scritta da parte del Venditore, nel momento in cui i Prodotti saranno consegnati e caricati dall'Acquirente.

## B.- Prezzi

**B.1.-** Salvo diversa pattuizione scritta, i prezzi di vendita concordati di volta in volta si intendono al netto per contanti e per consegna franco stabilimento del Venditore indicato nella Conferma d'Ordine.

## C.- Caratteristiche dei prodotti

**C.1.-** L'Acquirente dichiara di aver preso visione ed attenersi al contenuto della seguente documentazione pubblicata nel sito internet aziendale: 1) Manuale di Posa, Uso, Pulizia e Manutenzione e 2) Schede tecniche.

**C.2.** Data la intrinseca variabilità del prodotto ceramico, le caratteristiche dei campioni e/o modelli inviati in precedenza dal Venditore all'Acquirente sono da considerarsi indicativi e non vincolanti.

**C.3.** Salvo specifiche richieste da concordare prima della Conferma d'Ordine, il Venditore non garantisce che l'ordine del singolo articolo venga evaso tutto con un medesimo lotto di produzione.

## D.- Termini di consegna

**D.1.-** I termini di consegna sono da intendersi indicativi e la proroga di essi non può far maturare all'Acquirente alcun diritto a richiedere indennizzi, ogni eccezione rimossa.

**D.2.-** Se, trascorsi 10 (dieci) giorni dalla data di avviso di merce pronta, l'Acquirente non ritira il materiale, il Venditore si riserva di stabilire discrezionalmente un nuovo termine di consegna.

## E.- Resa e spedizione

**E.1.-** L'eventuale variazione della destinazione dei Prodotti, diversa da quella concordata in Conferma d'Ordine, deve essere comunicata dall'Acquirente per iscritto entro e non oltre il secondo giorno antecedente a quello previsto per il ritiro presso la sede del Venditore. Il Venditore si riserva la facoltà di non accettare la variazione

della destinazione dei Prodotti. Nel caso si verifichi che la destinazione effettiva del Prodotto sia stata diversa da quella dichiarata dall'Acquirente, il Venditore si riserva la facoltà di sospendere l'esecuzione delle forniture in corso e/o risolvere i contratti in corso senza che l'Acquirente possa rivendicare risarcimenti diretti e/o indiretti di alcun tipo.

**E.2.-** Salvo patto contrario, la fornitura della merce si intende Franco Fabbrica (EXW ai sensi degli Incoterms 2010) e ciò anche quando sia convenuto che la spedizione o parte di essa venga curata dal Venditore su mandato dell'Acquirente. In ogni caso i rischi passano all'Acquirente al più tardi con la consegna al primo trasportatore.

**E.3.-** Ferma restando l'estraneità del Venditore rispetto al contratto di trasporto, il Venditore non potrà essere indicato come "shipper" nella polizza di carico. La comunicazione del peso lordo del container allo spedizioniere, non costituisce alcuna assunzione di responsabilità da parte del Venditore ai fini della Convenzione SOLAS (Safety Of Life At Sea). In nessun caso tale comunicazione potrà essere intesa come VGM (Verified Gross Mass).

**E.4.-** L'Acquirente s'impegna affinché il mezzo inviato presso i magazzini del Venditore sia idoneo al carico in relazione alla natura dei Prodotti. Nel caso il mezzo che si presenta comporti significative difficoltà per le operazioni di carico, il Venditore si riserva di addebitare una penale pari al 4% del valore dei prodotti a copertura dei maggiori costi logistici.

Se il mezzo convenuto non è assolutamente idoneo, il Venditore si riserva la facoltà di negare le operazioni di carico senza che nulla possa essere richiesto dall'Acquirente a titolo di risarcimento per ogni onere diretto e/o indiretto che ne possa derivare.

**E.5.-** È compito dell'Acquirente incaricare il vettore di controllare i prodotti prima del carico; eventuali osservazioni in relazione all'integrità degli imballi e della rispondenza delle quantità caricate a quelle indicate sul documento di trasporto, devono essere sollevate dal vettore al momento del carico. Tali osservazioni devono essere riportate su tutte le copie dei documenti di trasporto, altrimenti i prodotti caricati s'intendono integri e completi. Ne deriva che il Venditore non si assume alcuna responsabilità in relazione a mancanze o danni dei prodotti non segnalati dal vettore.

**E.6.-** È altresì responsabilità dell'Acquirente incaricare il vettore di verificare le modalità e la stabilità del carico sul mezzo affinché durante il trasporto non si verifichino rotture e affinché siano rispettate tutte le disposizioni di sicurezza riguardanti la circolazione stradale.

## F.- Pagamenti

**F.1.-** Qualsiasi obbligazione di pagamento deve essere adempiuta presso la sede legale del Venditore. Eventuali pagamenti ad agenti, rappresentanti o ausiliari di commercio non si intendono effettuati finché le relative somme non pervengono al Venditore.

**F.2.-** È fatto divieto all'Acquirente di

eseguire il proprio adempimento mediante pagamenti provenienti da paesi diversi dal proprio paese di residenza se trattasi di paesi che non garantiscono un adeguato scambio di informazioni con l'Italia. In caso di violazione di tale divieto, il Venditore ha facoltà di risolvere il contratto per giusta causa senza che l'Acquirente possa vantare il diritto di ottenere alcun risarcimento per l'eventuale danno subito.

**F.3.-** Eventuali spese di bollo ed incasso effetti e tratte sono a carico dell'Acquirente. In caso di inadempimento, anche solo parziale, dal giorno fissato per il pagamento decorreranno a favore del Venditore gli interessi moratori nella misura prevista dal d.lgs. 09/10/2002 n. 231.

**F.4.-** Salvo diversi accordi scritti, l'Acquirente si impegna a non compensare alcun credito, comunque insorto, nei confronti del Venditore.

## G.- Reclami

**G.1.-** Al ricevimento dei Prodotti, l'Acquirente dovrà sottoporli ad accurato controllo attraverso un esame visivo effettuato conformemente alle indicazioni riportate al punto 7 delle norme UNI EN ISO 10545-2

**G.2.-** L'installazione e la posa dei Prodotti deve essere effettuata attenendosi scrupolosamente alle raccomandazioni inerenti le attività da svolgere prima e durante la posa in opera indicate nel documento 1) Manuale di Posa, Uso, Pulizia e Manutenzione pubblicato nel sito internet del Venditore e sulla confezione del prodotto e/o all'interno della stessa. Non sono considerati vizi

del Prodotto quelli generati da un'errata installazione e dalla mancata/errata manutenzione (difforni dalle indicazioni fornite nel 1) Manuale di Posa, Uso, Pulizia e Manutenzione), da una non idonea destinazione d'uso e/o dalla normale usura nel tempo.

**G.3.-** Fatti salvi i limiti di accettabilità previsti dalla norma internazionale EN 14411 (ISO 13006), le Parti riconoscono come Vizi Palesi i difetti dei Prodotti riscontrabili già al momento del loro ricevimento tali da rendere il materiale idoneo all'uso o da diminuirne in modo apprezzabile il valore. Rientrano in tale categoria i difetti come definiti nel documento 1) Manuale di Posa, Uso, Pulizia e Manutenzione pubblicato nel sito internet del Venditore. A titolo esemplificativo e non esaustivo si riconoscono come Vizi Palesi i difetti superficiali, i difetti di decorazione, di lappatura/levigatura, di calibro, di planarità, di ortogonalità-rettilineità, di spessore, le sbecature, i fuori tono, i toni mescolati e i Prodotti che presentano problemi da taglio/scaglie.

**G.4.-** Nel caso l'Acquirente rilevi Vizi Palesi dovrà fare reclamo al Venditore per iscritto, a pena di decadenza, entro 8 (otto) giorni dal ricevimento e tenere a disposizione del Venditore l'intera partita di materiale. Il reclamo dovrà riportare i dati di fatturazione e una precisa descrizione del vizio reclamato corredata, quando possibile, da immagini fotografiche. Qualora il reclamo dovesse risultare infondato, l'Acquirente si rende disponibile a risarcire

il Venditore delle spese sostenute per l'eventuale sopralluogo (perizie, viaggi ecc.).

**G.5.-** I Vizi Occulti dovranno essere notificati al Venditore mediante lettera raccomandata A.R., a pena di decadenza dalla garanzia, entro 8 (otto) giorni dalla data della scoperta del difetto.

**G.6.-** L'azione dell'Acquirente diretta a fare valere la garanzia per vizi si prescrive comunque nel termine di 12 (dodici) mesi decorrenti dalla consegna dei Prodotti.

#### **H.- Garanzia per vizi**

**H.1.** La garanzia del Venditore si intende limitata ai soli Prodotti di prima scelta e non ai Prodotti di seconda o terza scelta o di partite d'occasione con prezzi o sconti particolari quando debitamente segnalati in nota nella Conferma dell'Ordine.

**H.2.** Il Venditore non garantisce l'idoneità dei Prodotti ad usi particolari, ma soltanto le caratteristiche tecniche pubblicate nel sito internet nel documento 2) Schede tecniche. L'indicazione d'uso, anche quando presentata dal Venditore in cataloghi e manuali, è da ritenersi puramente indicativa. Sulla base delle caratteristiche tecniche riportate nelle 2) Schede Tecniche è sempre compito del progettista valutare l'idoneità del Prodotto alle condizioni specifiche di utilizzo in funzione delle sollecitazioni e delle variabili che si possono verificare nell'ambiente di destinazione alterandone le sue caratteristiche, a titolo d'esempio, all'intensità del traffico, alla qualità del traffico (calpestio in presenza di sabbia, di detriti...), alle eventuali condizioni climatiche avverse e a qualsiasi altra aleatorietà a cui

può essere esposto il materiale.

**H.3.- Nel caso risulti accertato che il Prodotto manifesti Vizi Palesi, come definiti al sub lett. G n.3, il Venditore provvederà alla sostituzione del Prodotto difettoso con altro avente caratteristiche pari o superiori o nel caso ciò non sia possibile ad una congrua riduzione del prezzo. In alternativa l'Acquirente avrà diritto, previa restituzione dei Prodotti viziati, al rimborso del prezzo pagato, maggiorato del costo del trasporto, con esclusione del risarcimento di ogni altro danno diretto e/o indiretto.**

**H.4.** La garanzia del Venditore deve ritenersi esclusa nel caso in cui il Prodotto affetto da Vizi Palesi (in tutto o in parte) sia stato utilizzato e/o comunque trasformato dovendosi ritenere che in tal modo l'Acquirente (o il suo cliente) abbia espresso la volontà di accettarli nello stato in cui si trovano.

**H.5** Nel caso risulti accertato che il Prodotto manifesti Vizi Occulti, la garanzia del Venditore è limitata alla sostituzione del materiale con altro avente caratteristiche pari o superiori e ove ciò non sia possibile al rimborso del prezzo pagato maggiorato del costo del trasporto. In ogni caso la garanzia del Venditore per ogni danno diretto e/o indiretto comunque originato dal prodotto difettoso, deve intendersi limitata ad una somma che non potrà superare il doppio del prezzo di vendita applicato dal Venditore in relazione

alla sola parte della fornitura difettosa.

**H.6.-** Nel caso l'Acquirente rivenda il Prodotto a soggetti tutelati dal codice del consumo (d.l. n.206/2005) sarà responsabile delle condizioni praticate se difformi da quelle qui riportate e dovrà accertarsi che i diritti del consumatore siano esercitati nel rispetto dei rimedi e dei termini fissati da tale codice. Nel caso sussistano i presupposti, il diritto di regresso e/o comunque di rivalsa spettanti all'Acquirente verso il Venditore/ produttore non potrà eccedere le esenzioni ed i limiti come fissati dal sub lett. G n.1 al sub lett. H n.5.

#### **I. Clausole solve et repete e risolutive**

**I.1.-** Ai sensi dell'art. 1462 del Codice Civile, per nessun motivo, ivi compresi pretesi vizi o difetti del materiale, l'Acquirente potrà sospendere o ritardare il pagamento del materiale ritirato, salva naturalmente la facoltà di ripetere quando possa dimostrare di avere indebitamente pagato.

**I.2.-** Nel caso di mutamento delle condizioni patrimoniali dell'Acquirente o di mancato pagamento anche parziale di prodotti già forniti, il Venditore può sospendere l'esecuzione delle forniture in corso e/o risolvere i contratti in corso senza che l'Acquirente possa rivendicare risarcimenti diretti e/o indiretti di alcun tipo.

#### **L.- Patto di riservato dominio**

**L.1.-** Fino a quando l'Acquirente non avrà provveduto all'integrale pagamento del prezzo, i Prodotti oggetto della fornitura rimarranno di proprietà del Venditore.

**L.2.-** Durante il periodo suddetto, l'Acquirente assumerà gli obblighi e le responsabilità del custode, e non potrà alienare, dare in uso, lasciare sequestrare o pignorare tali Prodotti senza dichiarare la proprietà del Venditore e dare immediato avviso a mezzo raccomandata A.R.

#### **M.- Forza maggiore**

**M.1.-** Ciascuna parte potrà sospendere l'esecuzione dei suoi obblighi contrattuali quando tale esecuzione sia resa impossibile o oggettivamente troppo onerosa da un impedimento imprevedibile indipendente dalla sua volontà, quale ad esempio: sciopero, boicottaggio, serrata, incendio, guerra (dichiarata o non), guerra civile, sommosse e rivoluzioni, requisizioni, embargo, interruzioni di energia, rotture straordinarie di macchinari, ritardi nella consegna di componenti o materie prime.

**M.2.-** La parte che desidera avvalersi della presente clausola dovrà comunicare immediatamente per iscritto all'altra parte il verificarsi e la cessazione delle circostanze di forza maggiore.

**M.3.-** Qualora la sospensione dovuta a forza maggiore duri più di 60 (sessanta) giorni, ciascuna parte avrà il diritto di risolvere il presente contratto, previo un preavviso di 10 (dieci) giorni, da comunicarsi alla controparte per iscritto.

#### **N.- Obbligo di riservatezza**

**N.1.-** L'Acquirente è tenuto ad osservare la più assoluta riservatezza su tutte le notizie di carattere tecnico (quali, in via meramente

esemplificativa, disegni, prospetti, documentazioni, formule e corrispondenza) e di carattere commerciale (ivi comprese le condizioni contrattuali, i prezzi d'acquisto, le condizioni di pagamento ...) apprese in esecuzione del presente Contratto.

**N.2.-** L'obbligo di riservatezza viene assunto per tutta la durata del Contratto, nonché per il periodo successivo alla sua esecuzione.

**N.3.-** In ogni caso di inosservanza dell'obbligo di riservatezza, la parte inadempiente è tenuta e risarcire all'altra tutti i danni che ne dovessero derivare.

#### **O.- Marchi e segni distintivi del venditore**

**O.1.-** L'utilizzo dei marchi, dei modelli ornamentali e delle opere d'ingegno in genere, in qualunque forma o modo di espressione (quali a titolo meramente esemplificativo, ma non esaustivo: immagini, foto, disegni, filmati, figure, strutture, etc.) costituenti proprietà intellettuale del Venditore, attraverso qualsiasi mezzo (quali a titolo meramente esemplificativo, ma non esaustivo: stampa, video, radio, internet, social media, piattaforme di messaggistica istantanea o VoIP, etc.) è severamente vietato. Qualsiasi deroga a tale divieto, anche solamente parziale, dovrà essere autorizzata per iscritto, caso per caso, dalla Direzione generale del Venditore.

#### **P.- Lingua del contratto, legge applicabile, giurisdizione e competenza**

**P.1.-** Il Contratto e le presenti condizioni sono redatti in lingua Italiana, la quale

prevarrà nel caso di divergenza con la traduzione in altre lingue.

**P.2.-** La definizione di qualsiasi controversia comunque relativa alle forniture è soggetta alla legge ed alla giurisdizione dello Stato Italiano e la competenza territoriale viene devoluta in via esclusiva al Tribunale di Reggio Emilia nella cui circoscrizione il Venditore ha la sua sede legale.

# General terms and conditions of sale

Rev.1a of 1st January 2018

## A.- Contract completion

**A.1.-** These general sales conditions govern every sales contract between the Seller and the Buyer and any amendment or exception thereof shall be agreed in writing.

**A.2.-** Any offers, credits and/or rebates granted by agents or other intermediaries, shall not be considered valid if they are not confirmed in writing by the Seller.

**A.3.-** The Buyer shall send the written orders to the Seller, directly or through the agents, and the orders shall include the codes of the required products, quantity, price and destination. The order sent by the Buyer is irrevocable.

**A.4.-** The sale shall be deemed completed when: (i) the Buyer receives a written confirmation from the Seller, via e-mail, fax or other electronic means, that complies with the terms and conditions of the order; or (ii) if the confirmation sent by the Seller contains conditions that differ from the order sent by the Buyer, when the latter accepts it in writing or in any case does not object within 7 (seven) days from reception; or (iii) if the Seller does not provide a written confirmation, when the products are delivered and loaded by the Buyer.

## B.- Prices

**B.1.-** The prices agreed upon for each individual sale are net prices for cash delivery ex works (the Seller's plant shall be specified in the order confirmation), unless otherwise agreed in writing.

## C.- Product characteristics

**C.1.-** The Buyer declares to have read and comply

with the content of the following documentation published on the corporate website: 1) Laying, use, cleaning and maintenance manual and 2) Technical data sheets.

**C.2.-** Given the intrinsic variability of the ceramic products, the characteristics of the samples, previously sent by the Seller to the Buyer, are purely illustrative and cannot be deemed binding.

**C.3.-** Unless specifically requested and agreed before the order confirmation, the Seller does not guarantee that the entire quantity of an article on order shall be sent from one same production lot.

## D.- Delivery terms

**D.1.-** The delivery terms are approximate and a delay does not give the Buyer any right to claim compensation, without any exception.

**D.2.-** If the Buyer does not collect the goods, after 10 (ten) days from the date of the "goods ready" notice, the Seller has the right – at its discretion – to establish a new delivery date.

## E.- Shipping arrangements and terms

**E.1.-** The Buyer must communicate any variation in the destination of the products, different from the one agreed in the order confirmation, in writing within, and no later than, the second day before the day foreseen for the collection at the Seller's premises. The Seller reserves the right not to accept the change of the product destination. If the actual destination of the product is different from the one stated by the Buyer, the Seller reserves the right to suspend the execution of the supplies underway

and/or to terminate the contracts in force and the Buyer shall not have the right to claim direct and/or indirect compensation of any type.

**E.2.-** Unless otherwise agreed, the goods shall be delivered ex-works (EXW - Incoterms 2010) and this shall also be the case when the parties agree that the delivery, or part of it, shall be arranged by the Seller on the Buyer's behalf. In any case, the risks shall transfer to the Buyer upon delivery to the first carrier.

**E.3.-** Without prejudice to the Seller's extraneity in relation to the transport contract, the Seller shall not be indicated as "shipper" on the bill of lading. The communication of the gross weight of the container to the Forwarding agent does not represent in any way the undertaking of any liability by the Seller as regards the SOLAS (Safety Of Life At Sea) Convention. In no event may the said communication be taken to be the VGM (Verified Gross Mass).

**E.4.-** The Buyer undertakes to ensure that the vehicle sent to the Seller's warehouse is suitable for the loading operations, considering the nature of the products. If the vehicle sent to collect the goods causes difficulties in the loading operations, the Seller reserves the right to charge a penalty, of 4% of the value of the products, to cover the extra logistics costs. If the vehicle sent is not at all suitable, the Seller reserves the right to refuse to load the goods and the Buyer shall not have the right to claim compensation for any direct and/or indirect cost that may arise therefrom.

**E.5.-** The Buyer is responsible for

assigning the carrier the task of checking the products before loading them; any observations concerning the condition of the packaging and the correspondence of the quantities loaded with those on the transport document must be made by the carrier upon collection of the goods. The said observations must be written on all the copies of the transport documents, otherwise the loaded products shall be considered to be complete and in good condition. As a result, the Seller shall not be liable for any missing or damaged products not reported by the carrier.

**E.6.-** The Buyer is also responsible for assigning the carrier the task of checking the loading procedure and the stability of the goods on the vehicle, in order to prevent damage during transport and to comply with all road safety provisions.

## F.- Payments

**F.1.-** All payments must be made to the Seller's registered office. Payments made to agents, representatives, or sales assistants shall not be considered as made until the amounts are received by the Seller.

**F.2.-** The Buyer shall not fulfil its payment obligations by making payments from countries other than its own country of residence, if the said countries do not guarantee an adequate exchange of information with Italy. In case of breach of the said prohibition, the Seller has the right to terminate the contract for just cause and the Buyer shall not have the right to claim compensation for any damage suffered.

**F.3.-** Any costs for stamp duty and bank draft fees shall be borne by the Buyer. Failure to fulfil, even only in part, the payment shall result in the application of interest on arrears in favour of the Seller, from the date established for the payment, as envisaged by legislative decree 09/10/2002 no. 231.

**F.4.-** Unless otherwise agreed in writing, the Buyer undertakes not to offset any receivables, of whatever nature, owed by the Seller.

## G.- Claims

**G.1.-** Upon receipt of the products, the Buyer shall perform a visual inspection in compliance with instructions provided in point 7 of UNI EN ISO 10545-2 standards.

**G.2.-** The products must be installed and fitted strictly respecting the recommendations related to the activities to be performed before and during the laying of the product specified in document 1) Laying, use, cleaning and maintenance manual, published on the Seller's website, and on the product packaging and/or inside the packaging. Faults caused by an incorrect installation and by missing/incorrect maintenance (different from instructions provided in document 1) Laying, use, cleaning and maintenance manual), by an unsuitable use and/or by normal wear over time shall not be considered product faults.

**G.3.-** With the exception of the limits of acceptability foreseen by the international EN 14411 (ISO 13006) standard, the parties acknowledge as identifiable faults those product defects that

are immediately visible upon receipt thereof and that make the material unsuitable for use or that significantly reduce its value. This category includes faults as defined in the document 1)

Laying, use, cleaning and maintenance manual, published on the Seller's website. Identifiable faults include, by way of a non-limiting example, superficial defects, decoration defects, defects concerning polishing, dimensions, surface flatness, straightness of sides/rectangularity and thickness, cracks, chippings or rough edges, non-compliant shades, mixed shades and products that feature problems deriving from the cutting process and/or from chips.

**G.4.-** If the Buyer finds an identifiable fault, it must be reported in writing to the Seller, within 8 (eight) days from receipt of the products; failure to send the claim shall result in the forfeiture and loss of such right.

The Buyer shall keep the entire lot of material readily available for the Seller. The claim shall include the invoice details and an accurate description of the claimed fault together with photographs, where possible. In the event that the claim proves to be unfounded, the Buyer shall refund the Seller any costs incurred for an inspection (expert's reports, travel, etc.).

**G.5.-** Hidden faults shall be notified to the Supplier in writing, by recorded delivery letter with advice of receipt, within 8 days from the date such fault is found, under penalty of forfeiture.

**G.6.-** The Buyer's right to make a claim for faults under warranty is valid for 12 (twelve) months

from the delivery of the products.

#### **H.- Warranty for faults**

**H.1.** The Seller's warranty is limited to first grade products and not second or third grade products or lots on offer with special prices or discounts, which must be duly specified with a note in the order confirmation.

**H.2.** The Seller does not guarantee the suitability of the products for particular uses, and only guarantees the technical specifications published on the website in the document 2) Technical data sheets. The indication for use is merely indicative, even when written in the Seller's catalogues and manuals. On the basis of the characteristics described in the document 2) Technical data sheets, the designer always has the task of assessing the suitability of the product for the specific use conditions, taking into account the stress and variables to which the product will be subjected, which may alter its characteristics; for example, the traffic intensity, quality of traffic (foot traffic with the presence of sand, debris...), adverse weather conditions and any other unpredictable factor to which the material may be exposed.

**H.3.- In the event that identifiable product faults are ascertained, as defined in sub section G no. 3, the Seller shall replace the faulty product with another one with equal or superior characteristics; should this not be possible, the Seller shall apply a significant price reduction. Alternatively, following the return of the faulty products,**

**the Buyer shall have the right to a refund of the price paid plus the transport cost, with the exclusion of compensation for any other direct and/or indirect damage.**

**H.4. The Seller's warranty shall not be valid if the products that have identifiable faults (totally or in part) have been used and/or in any case transformed, as this entails that the Buyer (or its customer) expressed the intention to accept them in the condition in which they were found.**

**H.5.- In the event that hidden product faults are ascertained, the Seller's warranty is limited to the replacement with other products of equal or superior characteristics; should this not be possible the Seller shall refund the price paid plus the transport cost.** In any case, the Seller's warranty for any direct and/or indirect damage caused by the faulty product, shall be limited to an amount that shall not be greater than double the selling price applied by the Seller, only in relation to the faulty part of the supply.

**H.6.-** In the event that the Buyer resells the product to subjects protected by the consumer code (law decree no. 206/2005), the former shall be responsible for the conditions applied, if different from those stated herein, and shall ensure that the consumer's rights are exercised, in relation to the remedies and terms established by the said code. If there are the grounds for the Buyer to exercise the right of recourse and/or make a claim against the Seller/ manufacturer, the said action shall take into

account or go beyond the exemptions and limits established in sub sections G no. 1 and H no. 5.

#### **I. Solve et repete (pay and then claim) and termination clauses**

**I.1.-** Pursuant to article 1462 of the Italian Civil Code, on no account may the Buyer suspend or delay payment of collected material, including in the event of alleged defects or faults in the material; this does not affect the right to claim back any payments made unduly (solve et repete).

**I.2.-** If the Buyer's financial situation changes or in the event of non-payment (even partial) of products already supplied, the Seller reserves the right to suspend the execution of the supplies underway and/or to terminate the contracts in force and the Buyer shall not have the right to claim direct and/or indirect compensation of any type.

#### **L.- Retention of ownership**

**L.1.-** The products supplied shall remain exclusive property of the Seller until the Buyer has paid the full amount.

**L.2.-** During the aforementioned period, the Buyer shall undertake the obligations and responsibilities as bailee (also referred to as custodian) and shall not transfer the said products, grant their use, let them be seized or distrained without declaring that the property is of the Seller, and the Buyer shall immediately inform the Seller by recorded delivery letter with advice of receipt.

#### **M.- Force majeure**

**M.1.-** Each party may suspend the fulfilment of its contractual obligations, when the said fulfilment

is impossible or objectively too costly due to an unforeseeable impediment independent from the parties, such as for example: strike, boycott, lockout, fire, war (declared or not), civil war, riots and revolutions, requisitions, embargo, power blackouts, extraordinary breakage of machinery, delays in the delivery of components or raw materials.

**M.2.-** The party that wishes to apply this clause shall immediately notify the onset and end of the circumstances of force majeure to the other party in writing.

**M.3.-** If the suspension due to force majeure lasts longer than 60 (sixty) days, each party shall have the right to terminate this contract, with a notice of 10 (ten) days to be notified to the counterparty in writing.

#### **N.- Confidentiality**

**N.1.-** The Buyer undertakes to maintain confidentiality as regards all information of a technical (such as, by way of a non-limiting example, drawings, tables, documentation, formulas and correspondence) and commercial nature (including contractual conditions, purchase prices, payment conditions...) gained during the performance of this contract.

**N.2.-** The confidentiality obligation shall be undertaken for the entire duration of this contract and for the period following its execution.

**N.3.-** In case of failure to uphold the confidentiality obligation, the non-fulfilling party shall pay the other party compensation for all damages that may

derive therefrom.

#### **O.- Seller's trademarks and distinctive signs**

**O.1.-** The use of trademarks, ornamental designs and creative works in general, in whatever form and manner of expression (such as, by way of a non-limiting example: images, photos, drawings, videos, shapes, structures, etc.) constituting the Seller's intellectual property, through any means (such as, by way of a non-limiting example: press, video, radio, internet, social media, instant messaging platforms or VoIP, etc.) is strictly forbidden. Any exception to the said prohibition, even only partial, must be authorised in writing, each time, by the Seller's general management.

#### **P.- Contract language, applicable law, jurisdiction and authority**

**P.1.-** The present CONTRACT is drafted in Italian, and in case of disputes the said version shall prevail over any translations in other languages.

**P.2.-** Any dispute concerning the supply of products shall be subject to Italian law and jurisdiction and the Court of Reggio Emilia, the town in which the Seller has its registered office, shall have sole local jurisdiction.

# Conditions générales de vente

Rév.1a du 1er Janvier 2018

## A.- Modalités de conclusion du contrat

**A.1.-** Les présentes Conditions Générales de Vente régissent tout contrat de Vente entre le Vendeur et l'Acheteur et toute modification ou dérogation de ces dernières doit être convenue par écrit.

**A.2.-** D'éventuelles offres, accréditations et / ou ristournes accordées par des agents ou par d'autres intermédiaires, ne seront réputées

valables que si elles sont confirmées par écrit par le Vendeur.

**A.3.-** L'acheteur envoie au Vendeur, directement ou par l'intermédiaire d'agents, des Commandes écrites qui doivent indiquer les codes des Produits demandés, les quantités, leur prix et leur destination. La commande envoyée par l'acheteur est irrévocable.

**A.4.-** La Vente doit être réputée conclue au moment où : (i) l'acheteur reçoit de la part du Vendeur une Confirmation écrite par e-mail, par télécopie ou par d'autres moyens télématiques, conforme aux conditions de la Commande ; ou (ii) en cas de Confirmation envoyée par le Vendeur contenant des conditions différant de la Commande envoyée par l'acheteur lorsque celui-ci l'accepte par écrit ou qu'il en soit s'il ne la conteste pas dans un délai de 7 (sept) jours à compter de la réception ; ou (iii) en l'absence d'une confirmation écrite de la part du Vendeur, au moment où les Produits seront livrés et chargés par l'acheteur.

## B.- Prix

**B.1.-** Sauf accord contraire, les prix de vente convenus au fur et à mesure sont réputés nets, pour les paiements en espèces

et les livraisons Franco l'établissement du Vendeur indiqué sur la Confirmation de Commande.

## C.- Caractéristiques des produits

**C.1.-** L'acheteur déclare avoir lu et s'en tenir au contenu de la documentation suivante publiée sur le site Internet de la société: 1) Manuel de Pose, d'Utilisation, de Nettoyage et d'Entretien et 2) Fiches techniques.

**C.2.** Vu la variabilité intrinsèque du produit en céramique, les caractéristiques des échantillons et / ou des modèles envoyés précédemment par le Vendeur à l'acheteur sont indicatifs et non contraignants.

**C.3.** Sauf en cas de demandes spécifiques à convenir avant la Confirmation de Commande, le Vendeur ne garantit pas la commande d'un article soit intégralement constituée par un même lot de production.

## D.- Délais de livraison

**D.1.-** Les délais de livraison s'entendent fournis à titre indicatif et leur prorogation ne donne en aucun cas le droit à l'acheteur de demander des indemnités, excluant dès à présent toute exception.

**D.2.-** Si l'acheteur ne retire pas le matériel, au bout d'un délai de 10 (dix) jours à compter de la date de l'annonce indiquant que la marchandise est prête, le Vendeur se réserve la faculté de fixer à sa discrétion un nouveau délai de livraison.

## E.- Livraison et expédition

**E.1.-** L'éventuelle variation de la destination des Produits, différente de celle convenue dans la Confirmation de Commande, doit être

communiquée par l'acheteur par écrit au plus tard le second jour qui précède le jour du retrait au siège du Vendeur. Le Vendeur se réserve la faculté de ne pas accepter la variation de la destination des Produits. Au cas où la destination effective du Produit serait différente de celle déclarée par l'acheteur, le Vendeur se réserve la faculté de suspendre l'exécution des fournitures en cours et / ou de résilier le contrat sans que l'acheteur puisse revendiquer des indemnités directes et / ou indirectes d'aucune sorte.

**E.2.-** Sauf accord contraire, la fourniture de la marchandise est livrée Départ Usine (EXW aux termes des Incoterms 2010) même si l'on a convenu que l'expédition ou une partie de cette dernière sera suivie par le Vendeur sur mandat de l'acheteur. En tout état de cause, les risques passent à l'acheteur au plus tard au moment de la livraison au premier transporteur.

**E.3.-** Sans préjudice du désintéret du Vendeur par rapport au contrat de transport, celui-ci ne pourra être indiqué comme le "shipper" dans le connaissance. La communication du poids brut du container à l'expéditeur, ne constitue pas une prise de responsabilité de la part du Vendeur aux fins de la Convention SOLAS (Safety Of Life At Sea). En aucun cas cette communication ne pourra être considérée comme le VGM (Verified Gross Mass).

**E.4.-** L'acheteur s'engage à ce que le véhicule envoyé aux entrepôts du Vendeur soit compatible avec la nature des Produits à charger. Si le véhicule qui se présente

comporte des difficultés significatives pour les opérations de chargement, le Vendeur se réserve la faculté de déliter une pénalité de l'ordre de 4 % de la valeur des produits pour couvrir les coûts logistiques supplémentaires. Si le véhicule convenu n'est absolument pas compatible, le Vendeur se réserve la faculté de refuser les opérations de chargement sans que l'acheteur ne puisse rien lui demander à titre de remboursement de toute dépense directe et / ou indirecte éventuelle.

**E.5.-** Il appartient à l'acheteur de charger le transporteur de contrôler les produits avant le chargement ; d'éventuelles observations concernant l'intégrité des emballages et la correspondance des quantités chargées avec celles indiquées sur le document de transport doivent être soulevées par le transporteur au moment du chargement. Ces observations doivent être indiquées sur toutes les copies des documents de transport ; dans le cas contraire, les produits chargés sont réputés intacts et complets. Il s'ensuit que le Vendeur décline toute responsabilité en cas d'absence ou de détérioration des produits non signalée par le transporteur.

**E.6.-** L'acheteur a également la responsabilité de charger le transporteur de vérifier les modalités et la stabilité du chargement sur le véhicule afin d'éviter les bris durant le transport et le respect de toutes les dispositions de sécurité concernant la circulation sur route.

## F.- Paiements

**F.1.-** Toute obligation

de paiement doit être accomplie au siège légal du Vendeur. Les éventuels paiements remis à des agents, à des représentants ou à des auxiliaires de commerce ne seront réputés effectués qu'au moment où le Vendeur percevra les sommes correspondantes.

**F.2.-** Il est interdit à l'acheteur d'effectuer des paiements depuis un pays différent de son pays de résidence et ne garantissant pas un échange d'informations correct avec l'Italie. En cas de violation de cette interdiction, le Vendeur a la faculté de résilier le contrat pour juste cause sans que l'acheteur ne puisse revendiquer le droit d'obtenir une quelconque réparation pour l'éventuel préjudice subi.

**F.3.-** Les éventuels frais de timbre et d'encaissement d'effets et de traites sont à la charge de l'acheteur. En cas de défaillance, même partielle, des intérêts de retard commencent à courir en faveur du Vendeur, à compter du jour fixé pour le paiement, dans la mesure prévue par le Décret Législatif italien n° 231 du 09/10/2002.

**F.4.-** Sauf accord écrit contraire, l'acheteur s'engage à ne compenser aucune créance échue.

## G.- Réclamations

**G.1.-** À la réception des Produits, l'acheteur devra soumettre ces derniers à un contrôle minutieux moyennant un examen visuel effectué conformément aux indications du point 7 des normes UNI EN ISO 10545-2.

**G.2.-** L'installation et la pose des Produits doivent être effectuées en suivant scrupuleusement les recommandations inhérentes aux

activités exercées avant et durant la pose indiquées sur le document 1) Manuel de Pose, d'Utilisation, de Nettoyage et d'Entretien, publié sur le site Internet du Vendeur ainsi qu'à l'extérieur et / ou à l'intérieur de l'emballage du produit. Les défauts dus à une installation erronée et à un entretien absent / erroné (ne respectant pas les indications fournies dans le 1) Manuel de Pose, d'Utilisation, de Nettoyage et d'Entretien), par un usage prévu inapproprié et / ou par l'usure normale due au temps ne sont pas considérés comme des vices du Produit.

**G.3.-** Sous réserve des limites d'acceptabilité prévues par la norme internationale EN 14411 (ISO 13006), les Parties reconnaissent comme des Vices Évidents les défauts des Produits existant dès la réception de sorte que le matériel devienne inutilisable ou qu'il perde une grande partie de sa valeur. Cette catégorie comprend les défauts définis dans le document 1) Manuel de Pose, d'Utilisation, de Nettoyage et d'Entretien publié sur le site Internet du Vendeur. À titre d'exemple non contraignant, on reconnaît comme des Vices Évidents les défauts de surface, de décoration, de polissage, de calibre, de planéité, d'orthogonalité-rectitude, d'épaisseur, les fissures, les ébréchés, les hors nuance, les nuances mélangées et les Produits qui présentent des problèmes de coupe - voile.

**G.4.-** Si l'acheteur relève des Vices Évidents, il devra présenter une réclamation écrite au

Vendeur, sous peine de déchéance, dans un délai de 8 (huit) jours à compter de la réception et tenir le lot complet de matériel à la disposition de ce dernier. La réclamation devra indiquer les données de facturation et une description précise du vice objet de la réclamation, accompagnée, si possible, de photographies. Si la réclamation devait s'avérer sans fondement, l'Acheteur est disposé à rembourser au Vendeur les dépenses encourues pour l'éventuelle visite des lieux (expertises, déplacements, etc.).

**G.5.-** Les Vices Cachés devront être notifiés au Vendeur par lettre recommandée avec avis de réception, sous peine d'annulation de la garantie, dans un délai de 8 (huit) jours à compter de la date de la découverte du défaut.

**G.6.-** L'action de l'Acheteur ayant pour but de faire valoir la garantie en cas de vices se prescrit dans un délai de 12 (douze) mois à compter de la livraison des Produits.

#### **H.- Garantie couvrant les vices**

**H.1.** La garantie du Vendeur est réputée limitée aux seuls Produits de premier choix et non aux Produits de second ou de troisième choix ou à des lots d'occasion auquel on applique des prix ou des remises particuliers lorsqu'ils sont dûment signalés dans les notes de la Confirmation de Commande.

**H.2.** Le Vendeur ne garantit pas l'adéquation des Produits à des usages particuliers, mais uniquement les caractéristiques techniques publiées sur le site Internet dans le document 2) Fiches

techniques. L'usage indiqué, également lorsqu'il est présenté par le Vendeur dans des catalogues et des manuels, est purement indicatif. Sur la base des caractéristiques techniques indiquées dans les 2) Fiches Techniques, le concepteur a toujours le devoir d'évaluer l'adéquation du Produit aux conditions spécifiques d'utilisation en fonction des contraintes et des variables pouvant se vérifier dans le lieu de destination et susceptibles d'en altérer les caractéristiques, par exemple, l'intensité et la qualité de la circulation (piétinement en présence de sable, de détritrus...), ainsi que les éventuelles conditions climatiques défavorables et toute autre incidence à laquelle peut être exposé le matériel.

**H.3.- Si l'on a constaté que le Produit présente les Vices Évidents définis à la lettre G n°3, le Vendeur remplacera le Produit défectueux par un autre produit ayant des caractéristiques analogues ou supérieures ou, lorsque cela est impossible, à une réduction cohérente du prix. En alternative, l'Acheteur aura droit, après la restitution des Produits défectueux, au remboursement du prix payé, majoré du prix du transport, à l'exclusion du remboursement de tout autre préjudice direct et / ou indirect.**

**H.4. La garantie du Vendeur doit être réputée exclue au cas où le Produit présentant des Vices Évidents (entièrement ou partiellement) aurait été utilisé et / ou du moins transformé ; dans ce cas, on considérera**

**que l'Acheteur (ou son client) a exprimé la volonté de les accepter en l'état.**

**H.5 Si l'on a constaté que le Produit présente des Vices Cachés, la garantie du Vendeur se limite au remplacement du matériel par du matériel ayant des caractéristiques analogues ou supérieures et, lorsque cela est impossible, au remboursement du prix payé majoré des frais de transport.**

En tout état de cause, la garantie du Vendeur couvrant tout dommage direct et / ou indirect causé par le produit défectueux, se limitera à une somme qui ne pourra pas dépasser le double du prix de vente appliqué par le Vendeur dans le cadre de la seule partie de la fourniture défectueuse.

**H.6.-** Si l'Acheteur revend le Produit à des clients protégés par le code de la consommation (Décret-loi italien n° 206/2005) il sera responsable des conditions appliquées si celles-ci diffèrent des conditions indiquées ici et il devra s'assurer que les droits du consommateur sont exercés dans le respect des remèdes et des délais fixés par ce code. Si les conditions sont réunies, le droit de retrait et / ou de recours revenant à l'Acheteur à l'encontre du Vendeur / fabricant ne pourra dépasser ni les exonérations ni les limites établies de la lettre G n°1 à la lettre H n°5.

#### **I. Clauses solve et repete et clauses résolutoires**

**I.1.-** Aux termes de l'art. 1462 du Code Civil italien, en aucun cas, y compris les prétendus vices ou défauts du matériel, l'Acheteur ne

pourra suspendre ou retarder le paiement du matériel retiré, sans préjudice naturellement de la faculté d'exiger lorsqu'il est en mesure de démontrer avoir indûment payé.

**I.1.-** En cas de variation des conditions patrimoniales de l'Acheteur ou de non-paiement même partiel de produits déjà fournis, le Vendeur se réserve la faculté de suspendre l'exécution des fournitures en cours et / ou de résilier les contrats sans que l'Acheteur ne puisse revendiquer des indemnités directes et / ou indirectes d'aucune sorte.

#### **L.- Pacte de réserve de propriété**

**L.1.-** Tant que l'Acheteur n'aura pas intégralement payé le prix, les Produits objet de la fourniture resteront la propriété du Vendeur.

**L.2.-** Au cours de la susdite période, l'Acheteur assumera les obligations et les responsabilités de gardien, et il ne pourra ni aliéner, ni confier, ni permettre la saisie desdits Produits sans déclarer la propriété du Vendeur et informer immédiatement ce dernier par lettre recommandée avec avis de réception.

#### **M.- Force majeure**

**M.1.-** Chacune des parties pourra suspendre l'accomplissement de ses obligations contractuelles lorsque cette exécution est rendue impossible ou objectivement trop onéreuse par un empêchement imprévisible indépendant de sa volonté comme : les grèves, les boycottages, les lock-outs, les incendies, les guerres (déclarées ou non), les guerres civiles, les révoltes

et les révolutions, les réquisitions, les embargos, les coupures de courant, les ruptures exceptionnelles de machines, les retards de livraison de composants ou de matières premières.

**M.2.-** La partie qui souhaite user de la présente clause devra communiquer immédiatement par écrit à l'autre partie la survenue et la cessation des circonstances de force majeure.

**M.3.-** Si la suspension due à une force majeure dure plus de 60 (soixante) jours, chacune des parties aura le droit de résilier le présent contrat, avec un préavis de 10 (dix) jours, en le communiquant par écrit à la partie adverse.

#### **N.- Obligations de confidentialité**

**N.1.-** L'Acheteur est tenu d'observer le secret le plus absolu concernant toutes les informations de caractère technique (comme, par exemple, les dessins, les notices, les documentations, les formules et la correspondance) et de caractère commercial (y compris les conditions contractuelles, les prix d'achat, les conditions de paiement, etc.) dont il aurait eu connaissance durant l'exécution du présent Contrat.

**N.2.-** L'obligation de confidentialité est assumée pendant toute la durée du Contrat, ainsi que pour la période successive à son exécution.

**N.3.-** Dans tous cas de non-observation de l'obligation de confidentialité, la partie défaillante est tenue de réparer à l'autre partie tous les éventuels préjudices.

#### **O.- Marques et signes**

#### **distinctifs du vendeur**

**O.1.-** L'utilisation des marques, des modèles ornementaux et des œuvres de l'esprit en général, sous quelque forme ou suivant quelque modalité d'expression que ce soit (à titre d'exemple, non contraignant : les images, les photos, les dessins, les vidéos, les figures, les structures, etc.) constituant la propriété intellectuelle du Vendeur, à travers tout moyen (à titre d'exemple non contraignant : l'impression, la vidéo, la radio, Internet, les médias sociaux, les plates-formes de messagerie instantanée ou VoIP, etc.) est formellement interdite. Toute dérogation à cette interdiction, même partielle, devra être autorisée par écrit, cas par cas, par la Direction générale du Vendeur.

#### **P.- Langue du contrat, loi applicable, juridiction et compétence**

**P.1.-** Le Contrat et les présentes conditions sont rédigés en langue italienne qui prévaudra en cas de divergence avec la traduction dans d'autres langues.

**P.2.-** La définition de toute controverse relative aux fournitures est régie par la loi et la juridiction de l'État italien et les parties reconnaissent la compétence territoriale exclusive du Tribunal de Reggio Emilia dans la circonscription duquel se trouve le siège légal du Vendeur.

# Allgemeine verkaufs- und lieferbedingunge

Fassung 1.a vom 1. Januar 2018

## A.- Modalität des vertragsabschlusses

**A.1.-** Die vorliegenden Allgemeinen Verkaufsbedingungen regeln alle Verträge zwischen dem Verkäufer und dem Käufer und alle Änderungen oder Abweichungen davon müssen schriftlich vereinbart werden.

**A.2.-** Eventuelle Angebote sowie mit Handelsvertretern oder sonstigen Vermittlern vereinbarten Gutschriften sind nicht verbindlich, es sei denn, sie werden vom Verkäufer schriftlich bestätigt.

**A.3.-** Der Käufer sendet dem Verkäufer direkt oder über Handelsvertreter schriftliche Bestellungen zu, die die Angabe der Artikelnummern der gewünschten Produkte, der Mengen, ihres Preises und der Bestimmung enthalten müssen. Die vom Käufer gesendete Bestellung ist unwiderruflich.

**A.4.-** Der Verkauf gilt zu dem Zeitpunkt als abgeschlossen, an dem: (i) der Käufer vom Verkäufer eine schriftliche Bestätigung per E-Mail, Fax oder auf sonstigem Weg erhält, die den Fristen und Bedingungen der Bestellung entspricht; oder (ii) falls die vom Verkäufer gesendete Bestätigung, Bedingungen enthält, die von der vom Käufer erhaltenen Bestellung abweichen, wenn dieser diese akzeptiert oder nicht innerhalb von 7 (sieben) Tagen ab ihrem Empfang beanstandet; oder (iii) falls keine schriftliche Bestätigung durch den Verkäufer erfolgt, zu dem Zeitpunkt, an dem die Produkte geliefert und vom Käufer übernommen werden.

## B.- Preise

**B.1.-** Vorbehaltlich abweichender schriftlicher Vereinbarungen gelten die von Mal zu Mal vereinbarten Verkaufspreise als Nettobarpreise bar mit

Lieferung frei ab dem in der Auftragsbestätigung angegebenen Werk des Verkäufers.

## C.- Eigenschaften der produkte

**C.1.-** Der Käufer erklärt, die folgende auf der Web-Site des Unternehmens veröffentlichte Dokumentation zur Kenntnis genommen zu haben und sich an deren Inhalt zu halten: 1) Handbuch zur Verlegung, Benutzung, Reinigung und Pflege, und 2) Technische Datenblätter.

**C.2.** Aufgrund der intrinsischen Variabilität des Keramikprodukts sind die Eigenschaften der vorausgehend vom Verkäufer an den Käufer gesendeten Warenmuster und/oder Modelle hinweisend und unverbindlich.

**C.3.** Vorbehaltlich spezifischer Vereinbarungen vor der Auftragsbestätigung garantiert der Verkäufer nicht, dass die Lieferung des einzelnen Artikels vollständig mit dem gleichen Produktionslos ausgeführt wird.

## D.- Lieferfristen

**D.1.-** Die Lieferfristen sind unverbindlich und Verzögerungen führen für den Käufer in keinem Fall zum Anspruch auf Schadensvergütung.

**D.2.-** Falls der Käufer das Material nicht innerhalb von 10 (zehn) Tagen ab dem Datum der Bereitstellung der Waren abholt, behält sich der Verkäufer das Recht vor, eine neue Lieferfrist festzusetzen.

## E.- Rücklieferung und versand

**E.1.-** Die eventuelle Änderung des Bestimmungsortes der Produkte, die sich von der in der Auftragsbestätigung vereinbarten unterscheidet, muss vom Käufer schriftlich innerhalb des zweiten Tags vor dem für die Abholung am Sitz des Verkäufers vorgesehenen mitgeteilt werden.

Der Verkäufer behält sich das Recht vor, die Änderung der Bestimmung der Produkte nicht zu akzeptieren. Falls sich herausstellt, dass die effektive Bestimmung des Produkts von der vom Käufer angegebenen verschieden ist, behält sich der Verkäufer das Recht vor, die laufenden Lieferungen nicht auszuführen und/oder die laufenden Verträge aufzulösen, ohne dass der Käufer jeglichen Anspruch auf Entschädigung geltend machen kann.

**E.2.-** Vorbehaltlich abweichender Vereinbarungen erfolgt die Lieferung der Ware frei ab Werk (EXW gemäß den Incoterms 2010), und dies auch, falls vereinbart wird, dass der Versand oder ein Teil desselben im Auftrag des Käufers durch den Verkäufer erfolgt. In jedem Fall gehen die Risiken spätestens mit der Übergabe an das erste Transportunternehmen an den Käufer über.

**E.3.-** Unter Beibehaltung der Nichtbeteiligung des Verkäufers am Transportvertrag kann der Verkäufer in der Police der Ladung als „Shipper“ angegeben werden. Die Mitteilung des Bruttogewichts des Containers an den Transportunternehmer stellt keine Übernahme der Verantwortung des Verkäufers hinsichtlich der SOLAS-Konvention dar (Safety Of Life At Sea). In keinem Fall kann diese Mitteilung als VGM (Verified Gross Mass) verstanden werden.

**E.4.-** Der Käufer verpflichtet sich sicherzustellen, dass das zu den Lagern des Verkäufers gesendete Fahrzeug unter Berücksichtigung der Natur der Produkte für das Laden geeignet ist. Falls das zum Laden gesendete Fahrzeug größere Probleme beim Beladen bereitet, behält der Verkäufer

sich das Recht vor, zur Abdeckung der höheren Logistikkosten eine Vertragsstrafe in Höhe von 4 % des Werts der Produkte zu erheben. Falls das Fahrzeug vollkommen ungeeignet ist, behält sich der Verkäufer das Recht vor, das Verladen zu verweigern, ohne dass der Käufer einen Anspruch auf Vergütung der Schäden geltend machen kann, die direkt und/oder indirekt daraus entstehen können.

**E.5.-** Es ist Aufgabe des Käufers, das Transportunternehmen zu beauftragen und die Produkte vor dem Laden zu kontrollieren; eventuelle Anmerkungen zur Unversehrtheit der Verpackungen und der Übereinstimmung der geladenen Menge mit der in den Transportpapieren angegebenen müssen vom Transportunternehmen zum Zeitpunkt des Ladens vorgenommen werden. Diese Anmerkungen müssen auf alle Exemplaren der Transportpapiere vermerkt werden, anderenfalls gelten die geladenen Produkte als unbeschädigt und vollständig. Daraus folgt, dass der Verkäufer keinerlei Haftung für Fehlmengen oder Beschädigungen der Produkte übernimmt, die vom Transportunternehmen nicht gemeldet werden.

**E.6.-** Es ist ebenfalls Aufgabe des Käufers, das Transportunternehmen zu beauftragen und die Modalität des Ladens auf das Fahrzeug zu überprüfen, damit es während des Transports nicht zu Brüchen kommt, sowie die Einhaltung der Sicherheitsbestimmungen der Straßenverkehrsordnung zu gewährleisten.

## F.- Zahlungen

**F.1.-** Alle Zahlungsverpflichtungen müssen am Firmensitz des Verkäufers erfüllt

werden. Eventuelle Zahlungen an Handelsvertreter oder Außendienstmitarbeiter gelten als nicht geleistet, bis sie beim Verkäufer eingehen.

**F.2.-** Es ist dem Käufer untersagt, die Zahlungen aus Ländern vorzunehmen, die vom Land seines Firmensitzes verschieden sind, falls diese Länder keinen angemessenen Informationsaustausch mit Italien gewährleisten. Im Fall der Verletzung dieses Verbots hat der Verkäufer das Recht, den Vertrag aus gutem Grund aufzulösen, ohne dass der Käufer eine Vergütung des entstandenen Schadens geltend machen kann.

**F.3.-** Eventuelle Kosten und Gebühren für die Einziehung von Effekten und Wechseln gehen zu Lasten des Käufers. Im Fall der Nichteinhaltung des für die Zahlung festgesetzten Tags - auch nur partiell - fallen Säumniszinsen zu Gunsten des Verkäufers an, in der vom ital. Gesetzlerlass vom 9. Oktober 2002, Nr. 231 vorgesehenen Höhe.

**F.4.-** Vorbehaltlich abweichender schriftlicher Vereinbarungen verpflichtet sich der Käufer, keine Guthaben gegenüber dem Verkäufer zu verrechnen.

## G.- Beanstandungen

**G.1.-** Beim Empfang der Produkte muss der Käufer eine sorgfältige Sichtkontrolle gemäß den Angaben von Punkt 7 der Normen UNI EN ISO 10545-2 unterziehen.

**G.2.-** Die Installation und die Verlegung der Produkte müssen unter Einhaltung der Empfehlungen zu den Arbeiten ausgeführt werden, die vor und während der Verlegung ausgeführt werden müssen, wie angegeben im Dokument 1)

Handbuch zur Verlegung, Verwendung, Reinigung und Pflege, veröffentlicht auf der Web-Site des Verkäufers und angegeben auf der Verpackung des Produkts und/oder im Inneren derselben. Schäden, die durch eine falsche Installation, Verlegung und durch eine unterlassene/falsche Pflege (abweichend von den Angaben in 1) Handbuch zur Verlegung, Reinigung und Wartung), durch eine ungeeignete Gebrauchsbestimmung oder durch normale Abnutzung verursacht werden, werden nicht als Mängel des Produkts anerkannt.

**G.3.-** Vorbehaltlich der Grenzen der Akzeptabilität, die von der internationalen Norm EN 14411 (ISO 13006) vorgesehen sind, erkennen die Parteien Mängel der Produkte als offensichtliche Mängel an, die bereits bei ihrem Empfang festgestellt werden können, die das Material zur Verwendung ungeeignet machen oder die den Wert beträchtlich verringern. In diese Kategorie fallen Mängel, wie im Dokument definiert

1) Handbuch zur Verlegung, Benutzung, Reinigung und Pflege, veröffentlicht auf der Web-Site des Verkäufers. Als nicht erschöpfende Beispiele werden Oberflächenmängel, fehlerhafte Grafik, Defekte polierte Oberfläche, Defekte des Kalibers, der Planarität, der Rechtwinkligkeit/ Gradlinigkeit, der Stärke, Risse, abgeschlagene Kanten, Fehlfarbe, gemischte Brandfarbe sowie Produkte mit Kantsplinterung durch Rettifizierung als offensichtliche Mängel anerkannt.

**G.4.-** Falls der Käufer offensichtliche Mängel feststellt, muss er dies dem Verkäufer innerhalb von 8 (acht) Tagen ab dem Empfang

schriftlich melden und die gesamte Charge des Materials für den Verkäufer zur Verfügung halten; anderenfalls verfällt der Rechtsanspruch. Bei der Beanstandung müssen die Daten der Rechnung sowie eine präzise Beschreibung des beanstandeten Mangels angegeben werden, falls möglich mit einer fotografischen Dokumentation. Falls die Beanstandung unberechtigt sein sollte, ist der Käufer gehalten, dem Verkäufer die für einen eventuellen Ortstermin aufgewendeten Kosten (Gutachten, Reisekosten, usw.) zu erstatten.

**G.5.-** Versteckte Mängel müssen dem Verkäufer innerhalb von 8 (acht) Tagen ab Feststellung des Mangels per Einschreiben mit Rückschein gemeldet werden; anderenfalls verfällt der Rechtsanspruch.

**G.6.-** Die Aktion des Käufers zur Inanspruchnahme der Mängelhaftung muss in jedem Fall innerhalb von 12 (zwölf) Monaten ab der Lieferung der Produkte erfolgen.

#### **H.- Mängelhaftung**

**H.1.** Die Garantie des Verkäufers ist begrenzt auf Produkte erster Qualität und sie bezieht sich nicht auf Produkte zweiter oder dritter Qualität oder auf gelegentliche Partien mit besonderen Preisen oder Nachlässe, die in der Auftragsbestätigung angegeben werden.

**H.2.** Der Verkäufer garantiert nicht die Eignung der Produkte für besondere Verwendungen, sondern lediglich die technischen Eigenschaften, die auf der Web-Site in Dokument 2) Technische Datenblätter veröffentlicht sind. Die Angabe zur Verwendung ist als unverbindlich anzusehen, auch wenn vom Verkäufer in Katalogen und Handbüchern angegeben ist. Es ist

stets Aufgabe des Planners, auf der Grundlage der in den 2) Technischen Datenblättern angegebenen Eigenschaften die Eignung des Produkts für spezifische Nutzungsbedingungen zu bewerten, unter Berücksichtigung der Belastungen sowie der Variablen, die am Ort der Bestimmung auftreten und die Eigenschaften verändern können, wie zum Beispiel die Intensität des Verkehrs, die Qualität des Verkehrs (Begehung bei Vorhandensein von Sand, Schmutz usw.), die eventuellen klimatischen Bedingungen sowie alle sonstigen Einflüsse, denen das Material ausgesetzt sein kann.

**H.3.- Falls festgestellt wird, dass das Produkt offensichtliche Mängel aufweist, wie definiert in Punkt G, Nr. 3, nimmt der Verkäufer die Ersetzung des mangelhaften Produkts durch ein anderes mit gleichen oder höherwertigen Eigenschaften vor, oder er nimmt eine angemessene Reduzierung des Preises vor, falls dies nicht möglich ist. Alternativ hat der Käufer nach Rücklieferung der mangelhaften Produkte das Recht auf Rückerstattung des bezahlten Preises, zuzüglich der Transportkosten, mit Ausschließung der Vergütung aller direkten und/oder indirekten Schäden.**

**H.4.** Die Garantie des Verkäufers wird ausgeschlossen, falls das mangelhafte Produkt (ganz oder teilweise) verwendet und/oder umgewandelt worden ist, da davon ausgegangen wird, dass der Käufer (oder sein Kunde) dadurch seinen Willen zum Ausdruck gebracht hat, es in dem Zustand zu akzeptieren, in dem es sich befindet.

**H.5** Falls festgestellt

**wird, dass das Produkt versteckte Mängel aufweist, ist die Garantie des Verkäufers auf die Ersetzung des Materials durch anderes mit gleichen oder höherwertigen Eigenschaften beschränkt oder - falls dies nicht möglich ist - auf die Rückerstattung des bezahlten Preises, zuzüglich der Transportkosten.** In jedem Fall ist die Garantie des Verkäufers für alle direkten und/oder indirekten Schäden, die durch das mangelhafte Produkt entstehen, auf einen Betrag begrenzt, der das Doppelte des Verkaufspreises nicht übersteigen kann, den der Verkäufer auf den mangelhaften Teil der Lieferung angewendet hat.

**H.6.-** Falls der Käufer das Produkt an Kunden weiterverkauft, die vom Verbraucherschutzgesetz (ital. Gesetzes Nr. 206/2005) geschützt werden, ist er verantwortlich für die angewendeten Bedingungen, falls diese von den hier angegebenen abweichen, und er muss sicherstellen, dass die Rechte des Verbrauchers gemäß den Bestimmungen dieses Gesetzes ausgeübt werden können. Falls die Voraussetzungen gegeben sind, kann das Regressrecht des Käufers gegenüber dem Verkäufer/Hersteller nicht die Grenzen übersteigen, die von Punkt G, Nr. 1 bis Punkt H, Nr. 5 angegeben werden.

#### **I. Klausel solve et repete und auflösungsklausel**

**I.1.-** Gemäß den Bestimmungen von § 1462 des ital. Bürgerlichen Gesetzbuches kann der Käufer in keinem Fall - einschließlich von vermeintlichen Mängeln oder Defekten des Materials - die Zahlung des abgenommenen Materials aussetzen oder verzögern, natür-

lich vorbehaltlich des Rechts, ungerechtfertigt gezahlte Beträge zurückzufordern, und dies nur nach Erbringung des Nachweises der Rechtmäßigkeit der Forderung (Solve et Repete).

**I.2.-** Im Fall der Veränderung der Vermögensbedingungen des Käufers oder der auch nur partiellen Nichtbezahlung der bereits gelieferten Produkte kann der Verkäufer die laufenden Lieferungen aussetzen und/oder die laufenden Verträge auflösen, ohne dass der Käufer die Vergütung von direkten und/oder indirekten Schäden geltend machen kann.

#### **L.- Eigentumsvorbehalt**

**L.1.-** Bis zur vollständigen Bezahlung des Preises durch den Käufer bleiben die Produkte, die den Gegenstand der Lieferung darstellen, Eigentum des Verkäufers.

**L.2.-** Während dieses Zeitraums übernimmt der Käufer die Pflichten und die Verantwortlichkeiten für die Aufbewahrung der gekauften Produkte und er kann sie nicht veräußern, zur Nutzung überlassen oder beschlagnahmen oder pfänden lassen, ohne das Eigentum des Verkäufers anzugeben und ohne diesen umgehend per Einschreiben mit Rückschein zu benachrichtigen.

#### **M.- Höhere Gewalt**

**M.1.-** Beide Parteien können die Ausführung der vertraglichen Pflichten aussetzen, wenn die Ausführung aus Gründen, die vom eigenen Willen unabhängig sind, unmöglich oder objektiv zu aufwendig wird, wie zum Beispiel: Streiks, Boykott, Aussperrung, Brand, Krieg (erklärt oder nicht), Bürgerkrieg, Aufstände und Revolutionen, Beschlagnahme, Embargo, Unterbrechungen der

Energieversorgung, außerordentliche Defekte von Maschinen, Verspätung bei der Anlieferung von Komponenten und Rohstoffen.

**M.2.-** Die Partei, die beabsichtigt, die vorliegende Klausel in Anspruch zu nehmen, muss der anderen Partei schriftlich das Auftreten von Umständen der Höheren Gewalt mitteilen.

**M.3.-** Falls die Aussetzung aufgrund von Höherer Gewalt mehr als 60 (sechzig) Tage andauert, haben beiden Parteien das Recht, den vorliegenden Vertrag nach einer schriftlichen Vorankündigung von 10 (zehn) Tagen an die Gegenpartei aufzulösen.

#### **N.- Vertraulichkeitspflicht**

**N.1.-** Der Käufer ist gehalten, über alle technischen Informationen (wie zum Beispiel Zeichnungen, Prospekte, Dokumentationen, Formeln und Schriftverkehr) und kommerziellen Informationen (einschließlich der Vertragsbedingungen, der Kaufpreise, der Zahlungsbedingungen usw.), in deren Kenntnis während der Ausführung des vorliegenden Vertrages kommt, absolute Vertraulichkeit einzuhalten.

**N.2.-** Die Vertraulichkeitspflicht wird für die Dauer des Vertrages sowie den Zeitraum nach seiner Ausführung übernommen.

**N.3.-** Im Fall der Nichteinhaltung der Vertraulichkeitspflicht ist die nicht einhaltende Partei gehalten, der anderen Partei alle daraus entstehenden Schäden zu vergüten.

#### **O.- Marken und kennzeichnungen des verkäufers**

**O.1.-** Die Verwendung von Marken, Ziermotiven und geistigem Eigentum im Allgemeinen in jeder Form sowie jeder Ausdrucksform

(als nicht erschöpfendes Beispiel: Bilder, Fotos, Zeichnungen, Filme, Abbildungen, Strukturen usw.), die intellektuelles Eigentum des Verkäufers sind, ist auf jede Weise (als nicht erschöpfendes Beispiel: Presse, Video, Radio, Internet, Social Media, Instant-Messaging-Plattform oder VoIP usw.) strengstens untersagt. Alle - auch nur partielle - Abweichungen von diesem Verbot müssen von Fall zu Fall schriftlich von der Generaldirektion des Verkäufers autorisiert werden.

#### **P.- Sprache des vertrags, anwendbares recht, rechtsprechung und gerichtstand**

**P.1.-** Der Vertrag und die vorliegenden Bedingungen werden in italienischer Sprache verfasst, die im Fall der Abweichung der Übersetzung in andere Sprachen Vorrang hat.

**P.2.-** Die Regelung aller Rechtssachen hinsichtlich der Lieferung unterliegt der Rechtsprechung des italienischen Staats und die territoriale Zuständigkeit liegt ausschließlich beim Bezirksgericht Reggio Emilia, dem Ort des Firmensitzes des Verkäufers.



# Algemene verkoopvoorwaarden

Rev.1a van 1 januari 2018

## A.- Wijze van sluiting van de overeenkomst

**A.1.-** Deze algemene verkoopvoorwaarden regelen iedere verkoopovereenkomst tussen de Verkoper en de Koper en iedere wijziging of afwijking hiervan moet schriftelijk worden overeengekomen.

**A.2.-** Eventuele offertes, kredieten en/of kortingen die door agenten of andere bemiddelaars zijn toegekend, worden niet als geldig beschouwd tenzij ze schriftelijk door de Verkoper zijn bevestigd.

**A.3.-** De Koper dient schriftelijke Orders die de codes van de bestelde Producten, de hoeveelheden, hun prijs en de bestemming moeten bevatten, rechtstreeks of via de agenten, naar de Verkoper te sturen. De door de Koper verzonden Order is onherroepelijk.

**A.4.-** De Verkoop dient als gesloten te worden beschouwd op het moment waarop: (i) de Koper van de Verkoper een schriftelijke bevestiging via e-mail, fax of andere telematica-middelen ontvangt, die overeenstemt met de algemene voorwaarden van de Order; of (ii) in geval van een door de Verkoper verzonden bevestiging met voorwaarden die verschillen van de van de Koper ontvangen Order, wanneer laatstgenoemde deze voorwaarden schriftelijk bevestigt of deze in ieder geval niet binnen 7 (zeven) dagen vanaf ontvangst betwist; of (iii) bij gebrek aan een schriftelijke bevestiging van de Verkoper, op het moment waarop de Producten worden geleverd en door de Koper in ontvangst worden genomen.

## B.- Prijzen

**B.1.-** Tenzij anders schriftelijk overeengekomen, zijn de overeengekomen

prijzen te beschouwen als nettoprijzen met levering af fabriek van de Verkoper, die in de Orderbevestiging is aangeduid.

## C.- Kenmerken van de producten

**C.1.-** De Koper verklaart de volgende op de internetsite van de onderneming gepubliceerde informatie te hebben gelezen en deze in acht te nemen: 1) Handleiding voor plaatsing, gebruik, reiniging en onderhoud en 2) Technische informatiebladen.

**C.2.-** Gezien de inherente variabiliteit van keramiekproducten, moeten de kenmerken van de eerder door de Verkoper aan de Koper gestuurde monsters en/of modellen als indicatief en niet-bindend worden beschouwd.

**C.3.-** Behoudens specifieke verzoeken die vóór de Orderbevestiging moeten worden overeengekomen, garandeert de Verkoper niet dat de bestelling van het afzonderlijke artikel in één enkele productiepartij wordt afgehandeld.

## D.- Leveringstermijnen

**D.1.-** De leveringstermijnen dienen als indicatief te worden beschouwd en de verlenging hiervan geeft de Koper in geen enkel geval een recht op schadevergoeding.

**D.2.-** Indien de Koper na 10 (tien) dagen vanaf de datum waarop is meegedeeld dat de goederen gereed zijn, het materiaal niet heeft afgehaald, behoudt de Verkoper zich het recht voor naar eigen goeddunken een nieuwe leveringstermijn vast te stellen.

## E.- Retourzending en verzending

**E.1.-** Een eventuele wijziging van de bestemming van de Producten, ten aanzien van de in de Orderbevestiging overeengekomen

bestemming, moet schriftelijk door de Koper minstens twee dagen vóór de geplande datum voor het afhalen van de producten bij de vestiging van de Verkoper worden meegedeeld. De Verkoper behoudt zich het recht voor de wijziging van de bestemming van de Producten niet te aanvaarden. In geval de feitelijke bestemming van het Product anders is gebleken dan de door de Koper aangegeven bestemming, behoudt de Verkoper zich het recht voor de uitvoering van de lopende leveringen te onderbreken en/of de lopende overeenkomsten te ontbinden, zonder dat de Koper zich op enige vorm van directe en/of indirecte vergoedingen kan beroepen.

**E.2.-** Tenzij anders overeengekomen, is de levering van de goederen als af fabriek (EXW volgens de Incoterms 2010) te beschouwen, ook wanneer is overeengekomen dat de verzending of een deel hiervan in opdracht van de Verkoper door de Verkoper wordt verricht. In ieder geval gaan de risico's op zijn laatst op het moment van overhandiging aan de eerste vervoerder op de Koper over.

**E.3.-** Onverminderd het feit dat de Verkoper niet in de vervoersovereenkomst is betrokken, kan de Verkoper niet als "shipper" in de vrachtbrief worden aangeduid. De mededeling van het brutogewicht van de container aan de expediteur vormt geen enkele aanvaarding van aansprakelijkheid van de kant van de Verkoper in het kader van het SOLAS-verdrag (Safety Of Life At Sea). In geen geval kan deze mededeling worden opgevat als VGM (Verified Gross Mass).

**E.4.-** De Koper zal ervoor zorgen dat het naar de magazijnen van

de Verkoper gestuurde vervoermiddel geschikt is voor de lading, met betrekking tot de aard van de Producten.

Indien het betreffende middel beduidende problemen voor het laden veroorzaakt, behoudt de Verkoper zich het recht voor een boete ter hoogte van 4% van de waarde van de producten toe te passen om de hogere logistieke kosten te dekken. Indien het middel in kwestie volledig ongeschikt blijkt, behoudt de Verkoper zich het recht voor het laden te weigeren, zonder dat de Koper enige vergoeding kan vorderen voor alle directe en/of indirecte lasten die hieruit kunnen voortkomen.

**E.5.-** Het is de taak van de Koper de vervoerder te gelasten de producten voor het laden te controleren; eventuele opmerkingen met betrekking tot de integriteit van de verpakkingen en de overeenstemming met de geladen hoeveelheden ten opzichte van hetgeen op het vervoersdocument is aangegeven, moeten door de vervoerder worden gemaakt op het moment van het laden. Deze opmerkingen moeten op alle kopieën van het vervoersdocument worden aangebracht; gebeurt dit niet, dan worden de geladen producten als integer en compleet beschouwd. Hieruit volgt dat de Verkoper op geen enkele wijze aansprakelijk is voor het eventuele ontbreken van of schade aan de producten, dat niet door de vervoerder is signaleerd

**E.6.-** De Koper dient de vervoerder eveneens te gelasten de wijzen en stabiliteit van het laden in het vervoermiddel te controleren zodat de producten niet breken tijdens het vervoer en gewaarborgd is dat alle

veiligheidsvoorschriften betreffende het wegverkeer in acht zijn genomen.

## F.- Betalingen

**F.1.-** Iedere verplichting tot betaling dient bij de statutaire zetel van de Verkoper te worden verricht. Eventuele betalingen aan agenten, vertegenwoordigers of verkoopassistenten worden als niet verricht beschouwd tot de betreffende bedragen aan de Verkoper worden overhandigd.

**F.2.-** De Koper mag zijn verplichting niet vervullen door middel van betalingen vanuit andere landen dan zijn land van vestiging, indien het om landen gaat die geen geschikte informatie-uitwisseling met Italië waarborgen. In geval van schending van dit verbod, heeft de Verkoper het recht de overeenkomst op grond van een dringende reden te ontbinden, zonder dat de Koper zijn recht op welke vergoeding ook voor eventueel opgelopen schade kan uitoefenen.

**F.3.-** Eventuele zegelrechten of incassokosten voor betalingsopdrachten of wisselbrieven zijn ten laste van de Koper. In geval van niet-nakoming, ook gedeeltelijk, van de verplichting, is de vertragsrente aan de Verkoper verschuldigd vanaf de voor betaling vastgestelde dag, in de mate voorzien in d.lgs [decreto legislativo] 09/10/2002 nr. 231.

**F.4.-** Tenzij anders schriftelijk overeengekomen, verbindt de Koper zich ertoe geen enkele vordering die hij ten aanzien van de Verkoper zou kunnen hebben, te compenseren.

## G.- Klachten

**G.1.-** Op het moment van ontvangst van de Producten dient de Koper deze visueel goed te controleren, overeenkomstig de

aanwijzingen van punt 7 van de normen UNI EN ISO 10545-2.

**G.2.-** Bij het plaatsen en aanbrengen van de Producten dient men strikt de aanwijzingen te volgen met betrekking tot de handelingen die vóór en tijdens het leggen moeten worden verricht, bevat in het document 1) Handleiding voor plaatsing, gebruik, reiniging en onderhoud, dat is gepubliceerd op de website van de Verkoper en op de verpakking van het product en/of hierin is bevat. De gebreken veroorzaakt door een onjuiste plaatsing en een gebrek aan/onjuist onderhoud (dat afwijkt van de aanwijzingen verschaft in 1) Handleiding voor plaatsing, gebruik, reiniging en onderhoud), door een oneigenlijk gebruik en/of door normale slijtage, worden niet als gebreken van het Product beschouwd.

**G.3.-** Onverminderd de acceptatiegrenzen voorzien in de internationale norm EN 14411 (ISO 13006), erkennen de partijen als zichtbare gebreken die gebreken van de Producten die al waarneembaar zijn op het moment van ontvangst en die het materiaal ongeschikt maken voor gebruik of de waarde ervan aanzienlijk verminderen. Tot deze categorie behoren de gebreken die zijn beschreven in document

1) Handleiding voor plaatsing, gebruik, reiniging en onderhoud, dat op de website van de Verkoper is gepubliceerd. Bij wijze van voorbeeld, zonder uitputtend te zijn, worden als zichtbare gebreken beschouwd: oppervlaktegebreken, gebreken van de decoraties, van het leppen/polijsten, het kaliber, de vlakheid, orthogonaliteit, rechtheid, dikte, barsten, chippen, kleurverschil, gemengde tinten en producten die problemen van

het snijden/ schilfers vertonen.

**G.4.-** Indien de Koper zichtbare gebreken opmerkt dient hij binnen 8 (acht) dagen na ontvangst schriftelijk een klacht bij de Verkoper in te dienen en de volledige partij materiaal ter beschikking van de Verkoper te houden. De klacht dient de gegevens van de betreffende factuur te bevatten, evenals een precieze beschrijving van het gebrek, zo mogelijk vergezeld van foto's. Wanneer de klacht onbegroot zou blijken, zal de Koper de Verkoper de door laatstgenomede gemaakte kosten voor een eventuele inspectie ter plaatse (deskundigenonderzoek, reiskosten, enz.) vergoeden.

**G.5.-** De verborgen gebreken dienen de Verkoper door middel van aangetekende brief met ontvangstbevestiging, op straffe van verval, binnen 8 (acht) dagen vanaf het bespeuren van het gebrek, worden meegedeeld.

**G.6.-** Beroepen van de Koper op de garantie voor gebreken zullen in elk geval na 12 (twaalf) maanden vanaf de levering van de Producten verjaard zijn.

## H.- Garantie voor gebreken

**H.1.** De door de Verkoper verleende garantie heeft uitsluitend betrekking op eerste keus-Producten en niet op tweede of derde keus-producten of voordelige partijen met speciale prijzen of kortingen die naar behoren in de Orderbevestiging zijn aangeduid.

**H.2.** De Verkoper staat niet garant voor de geschiktheid van de Producten voor bijzonder gebruik, maar garandeert alleen de technische kenmerken die op de website in document 2) Technische informatiebladen

zijn bevat. De gebruiksaanwijzing moet, ook wanneer deze door de Verkoper in catalogussen en handleidingen wordt gepresenteerd, als indicatief worden beschouwd. Op grond van de technische gegevens in document 2) Technische informatiebladen, is het altijd de taak van de ontwerper om de geschiktheid van de Producten te beoordelen voor de specifieke gebruiksomstandigheden met betrekking tot belastingen en variabelen die zich op de plaats van bestemming kunnen voordoen en de kenmerken van de producten kunnen veranderen, waaronder de intensiteit van het verkeer, het type verkeer (het betreden in aanwezigheid van zand, vuil, enz.), eventuele slechte weersomstandigheden en alle andere onzekere variabelen waaraan het materiaal kan zijn blootgesteld.

**H.3.-** Indien wordt vastgesteld dat het Product zichtbare gebreken zoals beschreven in punt G.3, vertoont, zal de Verkoper het defecte Product door een ander product met dezelfde of superieure kenmerken vervangen of, wanneer dit onmogelijk is, een redelijke prijsverlaging toepassen. Als alternatief heeft de Koper na teruggave van de gebrekkige Producten, recht op vergoeding van de betaalde prijs, verhoogd met de vervoerskosten; de vergoeding van iedere andere directe en/of indirecte schade is uitgesloten.

**H.4.** Er kan geen aanspraak op de garantie van de Verkoper worden gemaakt wanneer het Product met (geheel of gedeeltelijk) zichtbare gebreken is gebruikt en/of in elk geval is gewijzigd, aangezien dit wordt beschouwd alsof de Koper (of zijn

klant) heeft verklaard de producten in de staat waarin zij verkoren te accepteren.

**H.5.** Indien wordt vastgesteld dat het Product verborgen gebreken vertoont, is de garantie van de Verkoper beperkt tot de vervanging van het materiaal door een ander materiaal met dezelfde of superieure kenmerken en indien dit onmogelijk is, tot vergoeding van de betaalde prijs, verhoogd met de vervoerskosten. In elk geval dient de garantie van de Verkoper voor iedere directe en/of indirecte schade voortkomend uit het gebrekkige product, als beperkt te worden beschouwd tot een bedrag dat niet hoger is dan het dubbele van de door de Verkoper toegepaste verkoopprijs met betrekking tot uitsluitend het deel van de levering dat gebreken vertoont.

**H.6.-** Indien de Koper het Product doorverkoopt aan personen die beschermd zijn door de Italiaanse consumentenwet (d.l. [wetsbesluit] nr. 206/2005), zal hij aansprakelijk zijn voor de toegepaste voorwaarden indien deze verschillen van de hier weergegeven voorwaarden en dient hij ervoor te zorgen dat de rechten van de consument worden uitgeoefend met inachtneming van de rechtsmiddelen en voorschriften van deze wetgeving. Indien de voorwaarden hiervoor bestaan, kan het recht van regres en/of van verhaal van de Koper jegens de Verkoper/ producent niet de vrijstellingen en grenzen overschrijden zoals deze zijn bepaald in de punten G.1 t/m H.5.

## I. 'Solve et repetit' en ontbindingsclausules

**I.1.-** In de zin van art. 1462 van het Italiaans burgerlijk wetboek kan de Koper om geen

enkele reden, ook niet vanwege vermeende gebreken of defecten van het materiaal, de betaling van het overgenomen materiaal onderbreken of vertragen, waarbij hij natuurlijk de mogelijkheid behoudt om wat hij ten onrechte heeft betaald terug te vorderen.

**I.2.-** In geval van wijziging van de solvabiliteitsituatie van de Koper of van een - ook gedeeltelijke - niet-betaling van de af geleverde producten, kan de Verkoper de uitvoering van de lopende leveringen onderbreken en/of de lopende overeenkomsten ontbinden zonder dat de Koper zich op enige vorm van directe en/of indirecte vergoedingen kan beroepen.

## L.- VOORBEHOUD VAN EIGENDOMSRECHT

**L.1.-** Tot het moment waarop de Koper de volledige betaling van de Producten heeft verricht, blijven de Producten die het voorwerp van de levering vormen, eigendom van de Verkoper.

**L.2.-** Tijdens de voornoemde periode neemt de Koper de verplichtingen en verantwoordelijkheden aan van bewaarder en kan hij deze Producten niet verkopen, in bruikleen geven of in beslag laten nemen zonder de eigendom van de Verkoper te verklaren en laatstgenoemde hiervan onmiddellijk in kennis te stellen door middel van aangetekende brief met ontvangstbevestiging.

## M.- Overmacht

**M.1.-** Beide partijen kunnen de uitvoering van hun contractuele verplichtingen onderbreken wanneer deze uitvoering onmogelijk of objectief te duur is geworden vanwege een onvoorziene belemmering buiten toedoen van een van

beiden, zoals: staking, boycot, brand, (al dan niet verklaarde) oorlog, burgeroorlog, oproer en revolutie, verbeurdverklaring, energie-uitval, uitzonderlijke defecten aan machines, vertragingen in de levering van onderdelen of grondstoffen.

**M.2.-** De partij die zich op deze clausule wil beroepen dient onmiddellijk schriftelijk het optreden en de beëindiging van de omstandigheden van overmacht aan de andere partij mee te delen.

**M.3.-** Indien de door overmacht veroorzaakte onderbreking meer dan 60 (zestig) dagen duurt, heeft ieder partij, na een opzeggingstermijn van 10 (tien) dagen, het recht om de onderhavige overeenkomst te ontbinden, wat schriftelijk aan de wederpartij moet worden meegedeeld.

## N.- Geheimhoudingsplicht

**N.1.-** De Koper is verplicht tot absolute geheimhouding ten aanzien van alle berichten van technische (inclusief, maar niet daartoe beperkt, ontwerpen, brochures, documentatie, formules en correspondentie) en commerciële aard (waaronder de contractuele voorwaarden, aankooprijzen, betalingsvoorwaarden, enz.), waarvan hij kennisneemt tijdens de uitvoering van de onderhavige overeenkomst.

**N.2.-** De geheimhoudingsplicht is van toepassing gedurende de volledige duur van de Overeenkomst, alsmede in de periode die volgt op de uitvoering hiervan.

**N.3.-** In geval van niet-naleving van de geheimhoudingsplicht, is de partij die haar verplichting niet is nagekomen gehouden tot vergoeding van alle schade die hier even-

tueel uit voortkomt.

## O.- Merken en onderscheidende tekens van de verkoper

**O.1.-** Het gebruik van merken, siermodellen en creatieve werken in het algemeen, in welke vorm of wijze van expressie ook (inclusief, maar niet daartoe beperkt: afbeeldingen, foto's, tekeningen, structuren, enz.) die de intellectuele eigendom van de Verkoper vormen, door middel van welk middel ook (inclusief maar niet daartoe beperkt: drukwerk, video's, radio, internet, social media, instant messaging platforms, VoIP, enz.), is ten strengste verboden. Iedere, ook gedeeltelijke, afwijking van dit verbod dient voor ieder afzonderlijk geval schriftelijk door de algemene directie van de Verkoper te worden geautoriseerd.

## P.- Taal van de overeenkomst, toepasselijk recht en rechterlijke bevoegdheid

**P.1.-** De Overeenkomst en de onderhavige voorwaarden zijn in de Italiaanse taal opgesteld, die doorslaggevend is in geval van verschillen met de vertaling in andere talen.

**P.2.-** De beoordeling van geschillen met betrekking tot de leveringen is onderworpen aan het recht en de bevoegdheid van de Italiaanse Staat, waarbij de rechterlijke bevoegdheid uitsluitend die van de Rechtbank van Reggio Emilia is, in welke regio de Verkoper zijn statutaire zetel heeft.

# Condiciones Generales de Venta

Rev.1a de 1 de Enero 2018

## A.- Modalidades de celebración del contrato

**A.1.-** Las presentes Condiciones Generales de Venta disciplinan todo contrato de venta entre el Vendedor y el Comprador y toda modificación o cancelación debe ser establecida por escrito.

**A.2.-** Eventuales ofertas, acreditaciones y/o descuentos otorgados por agentes u otros intermediarios, no son considerados válidos mientras no sean confirmados por escrito por el Vendedor.

**A.3.-** El Comprador envía al Vendedor, directamente o a través de agentes, pedidos por escrito que deben contener la indicación de los códigos de los productos requeridos, de las cantidades, de sus precios y de su destino. El pedido enviado por el Comprador es irrevocable.

**A.4.-** La venta deberá considerarse perfeccionada desde el momento en que: (a) el Comprador recibe por parte del Vendedor una confirmación -escrita a través de e-mail, fax u otros medios telemáticos- conforme con los términos y según las condiciones del pedido; o (b) en caso de confirmación enviada por el Vendedor que contenga condiciones diferentes de las del pedido enviado por el Comprador cuando este las acepte por escrito o, en todo caso, no las cuestiona dentro de los 7 (siete) días sucesivos a la recepción; o (c) en ausencia de confirmación escrita por el Vendedor, en el momento en que los productos serán entregados y serán cargados por el Comprador.

## B.- Precios

**B.1.-** Salvo acuerdo escrito en contrario, los precios de venta acordados de manera puntual se entienden

al neto en efectivo y para entrega en el establecimiento del Vendedor indicado en la confirmación del pedido.

## C.- Características de los productos

**C.1.-** El Comprador declara haber visto y atenerse al contenido de la siguiente documentación publicada en el sitio internet de la empresa: 1) Manual de Colocación, Uso, Limpieza y Mantenimiento y 2) Fichas Técnicas.

**C.2.** Dada la intrínseca variabilidad del producto cerámico, las características de las muestras y/o modelos enviados anteriormente por el Vendedor al Comprador deben ser considerados como aproximados y no vinculantes.

**C.3.** Salvo especificaciones requeridas, a acordar antes de la confirmación del pedido, el Vendedor no garantiza que el pedido de un artículo en particular sea despachado como un mismo lote de producción.

## D.- Plazos de entrega

**D.1.-** Los plazos de entrega deben entenderse como aproximados y su prórroga no puede devengar a favor del Comprador ningún derecho a solicitar indemnizaciones, sin excepciones posibles.

**D.2.-** Si, una vez transcurridos 10 (diez) días desde la fecha de aviso de estar lista la mercancía, el Comprador no retira el material, el Vendedor se reserva de establecer discrecionalmente un nuevo plazo de entrega.

## E.- Entrega y transporte

**E.1.-** La eventual variación de lugar de destino de los productos, señalando uno diferente respecto de aquel acordado en la confirmación de pedido, debe ser comunicada por el Comprador

por escrito dentro del plazo máximo taxativo del penúltimo día previo al retiro desde el establecimiento del Vendedor. El Vendedor se reserva la facultad de no aceptar el cambio de lugar de destino de los Productos. En caso de verificarse que el destino efectivo del producto sea diferente de aquel declarado por el Comprador, el Vendedor se reserva la facultad de suspender la realización de los suministros en curso y/o de rescindir los contratos en curso sin que el Comprador pueda pedir resarcimientos directos y/o indirectos de ningún tipo.

**E.2.-** Salvo acuerdo en contrario, el suministro de la mercancía se entiende ex Works (EXW según Incoterms 2010) y ello también cuando se acuerde que el transporte o parte de él quede a cargo del Vendedor, según mandato del Comprador. En todo caso, los riesgos se transfieren al Comprador a más tardar con la entrega al primer transportador.

**E.3.-** Como confirmación del hecho de que el Vendedor es ajeno al contrato de transporte, el mismo no podrá ser indicado como "shipper" en la póliza de carga. La comunicación del peso bruto del contenedor al transportista no comporta ninguna asunción de responsabilidad de parte del Vendedor para los fines del Convenio SOLAS (Safety Of Life At Sea). De ninguna manera la antedicha comunicación podrá ser considerada como VGM (Verified Gross Mass).

**E.4.-** El Comprador se compromete a fin de que el vehículo enviado al establecimiento del Vendedor sea idóneo para cargar considerando la naturaleza de los productos. En caso de que el vehículo

que se presenta comporte significativas dificultades para las operaciones de carga, el Vendedor se reserva el derecho a incluir una recarga del 4 % del valor de los productos a cobertura de los mayores costos logísticos. Si el vehículo enviado para retirar la mercancía no es absolutamente idóneo, el Vendedor se reserva la facultad de negar las operaciones de carga sin que nada pueda requerir el Comprador a título de resarcimiento por todo eventual costo directo y/o indirecto que de ello pueda derivar.

**E.5.-** Es tarea del Comprador encargarse al transportista controlar los productos antes de cargarlos; eventuales observaciones sobre la integridad de los embalajes y la exactitud de las cantidades cargadas, así como aquellas puestas en el documento de transporte, deben ser presentadas por el transportista en el momento de cargar. Estas observaciones deben ser reproducidas en todas las copias de los documentos de transporte; de lo contrario los productos cargados se entienden íntegros y completos. De ello deriva que el Vendedor no se asume ninguna responsabilidad con referencia a faltas o daños en los productos no señalados por el transportista.

**E.6.-** Asimismo, es responsabilidad del Comprador encargarse al transportista verificar las modalidades y la estabilidad de la carga sobre el vehículo a fin de que durante el transporte no se produzcan roturas y que sean respetadas todas las disposiciones sobre seguridad relativas a la circulación por vías públicas.

## F.- Pagos

**F.1.-** Toda obligación de pago debe ser cumplida en la sede legal del Vendedor. Eventuales pagos a agentes, representantes o auxiliares de comercio no se entienden efectuadas mientras las respectivas sumas no lleguen a poder del Vendedor.

**F.2.-** Queda prohibido para el Comprador cumplir su propia obligación mediante pagos provenientes de países que no sean su propio país de residencia si se trata de países que no garantizan adecuado intercambio de informaciones con Italia. En caso de violación de esta prohibición, el Vendedor tiene facultad de rescindir el contrato por justa causa sin que el Comprador pueda pretender derecho de obtener algún resarcimiento por eventual daño sufrido.

**F.3.-** Eventuales gastos de sello fiscal y de cobro de letras de cambio y efectos comerciales quedan a cargo del Comprador. En caso de incumplimiento, incluso solo parcial, del día fijado para el pago, se devengarán a favor del Vendedor los intereses de mora en la medida prevista por el Decreto Leg. nº 231 del 09/10/2002.

**F.4.-** Salvo acuerdos escritos que lo contradigan, el Comprador se compromete a no compensar ningún crédito de cualquier forma creado respecto del Vendedor.

## G.- Reclamos

**G.1.-** Al recibir los productos, el Comprador deberá someterlos a cuidadoso control a través de un examen visual efectuado conforme según las indicaciones del punto 7.4 de las normas UNI EN ISO 10545-2.

**G.2.-** La instalación y colocación de los productos deberá

efectuarse respetando escrupulosamente las recomendaciones inherentes a las actividades a realizar antes y durante la colocación, indicadas en el documento 1) Manual de Colocación, Uso, Limpieza y Mantenimiento publicado en el sitio internet del Vendedor y en el embalaje del producto y/o en el interior del mismo. No son considerados como vicios del producto aquellos generados por una errónea instalación y error/falta de mantenimiento (intervenciones diferentes de las instrucciones proporcionadas en el 1) Manual de Colocación, Uso, Limpieza y Mantenimiento), por un uso inapropiado y/o por el normal desgaste con el pasar del tiempo.

**G.3.-** Sin perjuicio de los límites de aceptabilidad previstos por la norma internacional EN 14411 (ISO 13006), las partes reconocen como vicios evidentes los defectos de los productos constatables ya en el momento de su recepción y tales que impidan el uso previsto del material o reduzcan de modo apreciable su valor. Forman parte de esta categoría los defectos precisamente establecidos en el documento 1) Manual de Colocación, Limpieza y Mantenimiento publicado en el sitio internet del Vendedor. A título solo de ejemplo, se reconocen como vicios evidentes los defectos superficiales, los defectos de decoración, de lapeado/pulido, de calibre, de planitud, de ortogonalidad-rectilineidad, de espesor, las grietas, los astillados, las variaciones de tono, los tonos mezclados y los productos que presentan problemas de cortes/escamas.

**G.4.-** En caso de que el Comprador observe la presencia de vicios evidentes, deberá

presentar reclamo al Vendedor por escrito, so pena de extinción del derecho, dentro de los 8 (ocho) días sucesivos a la recepción y mantener a disposición del Vendedor la partida completa de material. El reclamo deberá indicar los datos de facturación y una precisa descripción del vicio observado incluyendo, en lo posible, imágenes fotográficas. En caso de que el reclamo debiera demostrarse luego ser infundado, el Comprador se declara dispuesto a resarcir al Vendedor por los gastos efectuados para realizar la respectiva constatación in situ (peritajes, viajes, etc.).

**G.5.-** Los vicios ocultos deberán ser notificados al Vendedor mediante carta certificada con aviso de recibo, bajo pena de caducidad de la garantía, dentro de los 8 (ocho) días a contar de la fecha del descubrimiento del defecto.

**G.6.-** La acción del Comprador tendiente a hacer valer la garantía por vicios prescribe, en todo caso, en el plazo de 12 (doce) meses a contar de la entrega de los productos.

#### **H.- Garantía por vicios**

**H.1.** La garantía del Vendedor se entiende limitada solo a los productos de primera selección y no a los productos de segunda o tercera selección o de partidas de ocasión con precios o descuentos especiales cuando ello se encuentra debidamente señalados en nota en la confirmación del pedido.

**H.2.** El Vendedor no garantiza la idoneidad de los productos para usos particulares, sino solo las características técnicas publicadas en el sitio internet, documento 2) Fichas Técnicas. La indicación de uso, incluso cuando es presentada por el

Vendedor en catálogos y manuales, debe considerarse solo como genérica. Sobre la base de las características técnicas señaladas en las 2) Fichas Técnicas, es siempre tarea del proyectista evaluar la idoneidad del producto en función de las condiciones específicas de uso en consideración de las solicitudes y de las variables que pueden operar en el ambiente de destino, alterando sus características; a título de ejemplo: la intensidad del tráfico, la calidad del tráfico (tránsito en presencia de arena, de detritos, etc.), las eventuales condiciones climáticas adversas y cualquier otro factor aleatorio al que puede quedar expuesto el material.

**H.3.- En caso de comprobarse que el producto manifieste vicios evidentes, tal como han sido definidos en la letra G nº. 3, el Vendedor procederá a sustituir el producto defectuoso con otro con características iguales o superiores o, en el caso de que ello no sea posible, deberá efectuar una congrua reducción del precio. Como alternativa, el Comprador tendrá derecho, previa devolución de los productos viciados, al reembolso del precio pagado, agregándose el costo del transporte, con exclusión del resarcimiento de todo otro daño, directo y/o indirecto.**

**H.4. La garantía del Vendedor debe considerarse excluida en caso de que el producto que presenta vicios evidentes (total o parcialmente) haya sido utilizado y/o, en cualquier caso, transformado, debiéndose estimar que de tal modo el Comprador (o su cliente) ha expresado la voluntad de aceptarlo en el estado**

**en que se encuentra.**

**H.5 En los casos en que quede comprobado que el producto presenta vicios ocultos, la garantía del Vendedor queda limitada a la sustitución del material con otro de características iguales o superiores y, allí donde ello no sea posible, al reembolso del precio pagado, agregándose el costo del transporte.** En todo caso, la garantía del Vendedor por cada daño directo y/o indirecto de cualquier forma derivado de producto defectuoso, debe entenderse limitada a una suma que no podrá superar el doble del precio de venta aplicado por el Vendedor, con referencia solo a la parte defectuosa del suministro.

**H.6.-** En caso de que el Comprador revenda el producto a terceros protegidos por el código del consumo (D.L. n.º. 206/2005), será responsable de las condiciones practicadas si son diferentes de aquellas aquí señaladas y deberá comprobarse que los derechos del consumidor sean ejercidos con aplicación de los remedios y de los términos fijados por el antedicho código. En caso de subsistir las condiciones, el derecho de devolución y/o, en todo caso, de compensación a favor del Comprador respecto del Vendedor/productor, no podrán excederse las exenciones ni límites establecido en la letra G del n.º. 1 y en la letra H n.º. 5.

#### **I. Cláusulas solve et repete y resolutivas**

**I.1.-** De conformidad con lo dispuesto por el art. 1462 del Código Civil, por ningún motivo, incluidos supuestos vicios o defectos del material, el Comprador podrá suspender o

retardar el pago del material retirado, sin perjuicio obviamente de la facultad de restitución cuando pueda demostrar que ha pagado indebidamente.

**I.2.-** En el caso de cambiar las condiciones patrimoniales del Comprador o de falta de pago incluso parcial de productos ya suministrados, el Vendedor podrá suspender la realización de los suministros en curso y/o rescindir los contratos en curso sin que el Comprador pueda reivindicar resarcimientos directos ni indirectos de cualquier clase.

#### **L.- Pacto de reserva de dominio**

**L.1.-** Mientras el Comprador no haya efectuado el pago integral del precio, los productos objeto del suministro seguirán siendo de propiedad del Vendedor.

**L.2.-** Durante el período antedicho, el Comprador asumirá las obligaciones y las responsabilidades del depositario y no podrá enajenar, entregar en uso ni dejar retener o embargar los productos sin declarar la propiedad del Vendedor y enviar inmediatamente aviso con carta certificada con aviso de recibo.

#### **M.- Fuerza mayor**

**M.1.-** Cada parte podrá suspender la ejecución de sus obligaciones contractuales cuando esa ejecución se haga imposible u objetivamente demasiado onerosa por impedimento imprevisible independiente de su voluntad, tal como por ejemplo: huelga, boicot, bloqueo, incendio, guerra (declarada o no declarada), guerra civil, rebelión y revolución, requisición, embargo, interrupción de energía, rotura extraordinaria de maquinaria, retraso en la entrega

de componentes o materias primas.

**M.2.-** La parte que desee valerse de la presente cláusula deberá comunicar de inmediato por escrito a la otra parte el verificarse y el cese de las circunstancias de fuerza mayor.

**M.3.-** En caso de que la suspensión causada por fuerza mayor dure más de 60 (sesenta) días, cada una de las partes tendrá derechos de rescindir el presente contrato, con preaviso de 10 (diez) días, a comunicar a la otra parte por escrito.

#### **N.- Obligación de confidencialidad**

**N.1.-** El Comprador debe mantener la más absoluta confidencialidad respecto de todas las informaciones de carácter técnico (tales como, solo como ejemplo, diseños, prospectos, documentaciones, fórmulas y correspondencia) y de carácter comercial (incluidas las condiciones contractuales, los precios de compra, las condiciones de pago, etc.) obtenidas a propósito de la ejecución del presente contrato.

**N.2.-** La obligación de confidencialidad es válida por toda la duración del contrato, así como por el período sucesivo a su ejecución.

**N.3.-** En cualquier caso de inobservancia de la obligación de confidencialidad, la parte incumplidora deberá indemnizar a la otra por todos los daños que de ello puedan derivar.

#### **O.- Marcas y signos distintivos del vendedor**

**O.1.-** Queda severamente prohibido el uso a través de cualquier medio (tales como, solo a título de ejemplos no exhaustivos: prensa, videos, radio, internet, social media, plataformas de mensa-

jería instantánea o VoIP, etc.) de las marcas, de los modelos ornamentales y de las obras del ingenio en general que constituyan propiedad intelectual del Vendedor y ello en cualquier forma o modo de expresión (tales como, solo a título de ejemplos no exhaustivos: imágenes, fotos, dibujos, videos, figuras, estructuras, etc.). Cualquier excepción a esta prohibición, incluso solo parcial, deberá ser autorizada caso por caso por escrito por la dirección general del Vendedor.

#### **P.- Idioma del contrato, ley aplicable, jurisdicción y competencia**

**P.1.-** El contrato y las presentes condiciones son redactados en lengua italiana, la cual prevalecerá en caso de divergencia con las traducciones en otros idiomas.

**P.2.-** La resolución de cualquier controversia de cualquier forma relativa al suministro queda sujeta a la ley y a la jurisdicción del Estado Italiano y la competencia territorial es asignada de forma exclusiva al Tribunal de Reggio Emilia, en cuya circunscripción el Vendedor tiene su domicilio legal.

**Qualità certificata**

Ceramiche Refin SpA è certificata secondo ISO 9001. Tutto il processo produttivo è sottoposto a controlli severi per una garanzia di alta qualità.

Ceramiche Refin si riserva il diritto di apportare in qualsiasi momento modifiche o variazioni ai prodotti presenti in questo catalogo.

La proprietà intellettuale del presente catalogo è riservata per tutti i Paesi. La traduzione, la riproduzione, la memorizzazione elettronica e l'adattamento totale o parziale e con qualsiasi mezzo (compresi microfilm e copie fotostatiche) dei suoi contenuti comporta la violazione dei diritti di copyright di REFIN SpA. I prodotti raffigurati nelle immagini del presente catalogo sono protetti secondo la normativa vigente in materia di proprietà industriale.

Le informazioni contenute nel presente catalogo sono il più possibile esatte, ma non sono da ritenersi legalmente vincolanti. Per esigenze di produzione ci riserviamo il diritto di apportare eventuali modifiche che si rendono necessarie. Peso, colori e misure sono soggetti alle inevitabili variazioni tipiche del processo di cottura della ceramica. I colori indicati si avvicinano quanto più possibile a quelli reali nei limiti consentiti dai processi di stampa. I consigli e le istruzioni date pur essendo oggetto di studi e prove eseguite con la massima serietà, sono da ritenersi puramente indicative. Le caratteristiche tecniche riportate su questo catalogo annullano e sostituiscono quelle preesistenti nel precedente catalogo generale e nei cataloghi di serie.

**Certified quality**

Ceramiche Refin SpA is ISO 9001 certified. The entire production process is subject to strict controls for guaranteed high-quality materials.

Ceramiche Refin reserves the right to change the products presented in this catalogue at any time.

All the intellectual property rights of this catalogue are reserved in all countries. Translation, reproduction in print or electronic form, and adaptation, in whole or in part, using any means (including microfilm and photocopy formats) of the contents of the said catalogue constitute a violation of REFIN SpA's copyright. The products featured in the photographs in this catalogue are protected by current industrial property legislation.

The information contained in this catalogue is correct to the best of our knowledge, but is not to be construed as legally binding. We reserve the right to make change as and when production requirement under them necessary. The governing Size are the metric ones – measurements in inches are for only. Weight, colours and Size are subject to the usual variation expected in fi red ceramic products. Colours shown are as close to the real colour as the limitation of the printing process will allow. While being the result of carefully effected studies and tests, these suggestions and instructions should be considered purely indicative. The technical characteristics given in this catalogue cancel and replace all previous characteristics in the general catalogue and in the range catalogues.

**Qualité certifiée**

Ceramiche Refin SpA est certifiée selon ISO 9001. Tout le procédé de production est soumis à des contrôles rigoureux afin de garantir un matériau haut de gamme.

Ceramiche Refin se réserve à tout moment la faculté d'apporter des modifications ou des variations sur les produits présentés sur ce catalogue.

La propriété intellectuelle de ce catalogue est réservée, pour tous les pays. Toute traduction, reproduction, mémorisation par voie électronique et adaptation, intégrale ou partielle, par quelque procédure que ce soit (y compris les microfilms et les photocopies), de son contenu, est illicite et constitue la violation des droits de copyright de REFIN SpA. Les produits représentés sur les images de ce catalogue sont protégés, conformément à la réglementation en vigueur en matière de propriété industrielle.

Les renseignements contenus dans ce catalogue sont le plus possible exacts, mais ils ne sont sous la tutelle d'aucune jurisprudence. A cause d'exigences de production, nous nous réservons le droit d'apporter d'éventuelles modifications qui seront nécessaires. Les poids, coloris et mesures sont sujets à d'inévitables variations typiques au processus de cuisson de la céramique. Les couleurs indiquées sont fi dèle dans les limites consenties par les procédés d'imprimerie. Le conseils et les données, tout en étant le résultat d'études et d'essais très soignés, doivent être considérés comme purement indicatifs. Les caractéristiques techniques indiquées dans ce catalogue annulent et remplacent les caractéristiques qui étaient présentes dans le précédent catalogue général et dans les catalogues de série.

**Zertifizierte qualität**

Ceramiche Refin SpA ist nach ISO 9001 zertifiziert. Das gesamte Produktionsverfahren unterliegt strengsten Kontrollen, um höchste Qualitätsstandards gewährleisten zu können.

Die Firma Ceramiche Refin behält sich das Recht vor, jederzeit Änderungen an den in Katalog aufgeführten Produkten vorzunehmen.

Das geistige Eigentum ist für alle Länder geschützt. Die Übersetzung, Vervielfältigung, elektronische Speicherung und vollständige oder teilweise Verarbeitung seiner Inhalte mit jeglichem Mittel (einschließlich Mikrofilm und Fotokopie) bewirkt die Verletzung der Urheberrechte von REFIN SpA. Die im vorliegenden Katalog abgebildeten Produkte sind gemäß den geltenden einschlägigen Bestimmungen zum gewerblichen Eigentumsrecht geschützt.

Die im vorliegenden Katalog enthaltenen Angaben sind so genau wie möglich gehalten, sind aber rechtlich unverbindlich. Falls produktionsstechnisch erforderlich, behalten wir uns vor eventuelle Minderungen vorzunehmen. Gewicht, Farbe und Ausmasse der Fliesen unterliegen der unumgekehrlichen Toleranzen eines keramischen Ofenbrandes. Die abgebildeten Farben entsprechen Innerhalb der drucktechnischen Grenzen der Wirklichkeit. Die vorstehenden Anleitungen sind zwar das Ergebnis von Studien und Tests, die mit einem Höchstmaß in Seriosität durchgeführt wurden, aber dennoch nur als Orientierungswerte zu verstehen. Die in diesem Katalog angegebenen, annullieren und ersetzen die im früheren Hauptkatalog bzw. Katalogen der einzelnen Serien gemachten Angaben.

**Gecertificeerde Kwaliteit**

Ceramiche Refin SpA is gecertificeerd volgens ISO 9001, het gehele productieproces wordt aan strenge controles onderworpen ter garantie van een hoge kwaliteit.

Ceramiche Refin behoudt zich het recht voor om op elk moment wijzigingen of variaties aan de producten in deze catalogus door te voeren.

De intellectuele eigendom van deze catalogus is voor alle landen voorbehouden. De vertaling, de reproductie, de elektronische opslag en de totale of gedeeltelijke aanpassing met welk middel dan ook (inclusief microfilm en fotokopieën) van de inhoud van deze catalogus brengt de schending van de copyright van REFIN SpA. met zich mee. De producten getoond in de afbeeldingen van deze catalogus zijn beschermd volgens de geldende wetgeving inzake industriële eigendom.

De informatie in deze catalogus is zo exact mogelijk, maar moet niet als wettelijk bindend worden beschouwd, voor productieredenen behouden wij ons het recht voor eventueel de nodige wijzigingen aan te brengen. Gewicht, kleuren en maten zijn aan onvermijdelijke wijzigingen onderhevig die typisch zijn voor het bakproces van de keramiek. De aangegeven kleuren komen zo dicht mogelijk bij de echte kleuren, binnen de limieten die zijn toegestaan bij de drukprocedure. Het advies en de instructies die zijn gegeven moeten, ook al zijn ze onderwerp van studies en tests die met maximale ernst zijn uitgevoerd, enkel als indicatief worden beschouwd. De technische eigenschappen die in deze catalogus zijn aangegeven annuleren en vervangen de eerder bestaande eigenschappen in de vorige algemene catalogus en in de standaardcatalogi.

**Calidad certificada**

Ceramiche Refin SpA está certificada mediante la norma ISO 9001. Todo el proceso productivo está expuesto a severos controles para una garantía de alta calidad.

Ceramiche Refin se reserva el derecho de aportar en cualquier momento modificaciones o variaciones a los productos presentes en este catálogo.

La propiedad intelectual de este catálogo está reservada para todos los países. La traducción, reproducción, almacenamiento electrónico y la adaptación total o parcial por cualquier medio (microfilms y copias comprimidas) de los contenidos, significa la violación de los derechos de autor de Ceramiche Refin SpA. Los productos reflejados en las imágenes del presente catálogo están protegidos de acuerdo a la norma vigente en materia de propiedad industrial.

La información contenida en el presente catálogo son lo más exactas posibles pero no pretenden ser legalmente vinculantes. Por exigencia de producción se reserva el derecho de aportar eventuales modificaciones que resulten necesarias. Peso, color y dimensión están sujetos a las inevitables variaciones típicas del proceso de cocción de la cerámica. Los colores indicados se acercan lo máximo posible a aquellos reales dentro de los límites del proceso de impresión. Los consejos e instrucciones dadas, a pesar de ser objetos de estudio y pruebas realizadas con la máxima seriedad, se consideran puramente indicativos. Las características técnicas detalladas en este catálogo anulan o sustituyen las ya existentes en catálogos precedentes tanto generales como de serie.

